



BURR KING MFG. CO., INC

1220 Tamara Lane

Warsaw, MO 65355

www.burrking.com

(660)438-8998 • 800-621-2748

Fax (660)438-8991

MODEL 1000

INSTRUCTION MANUAL

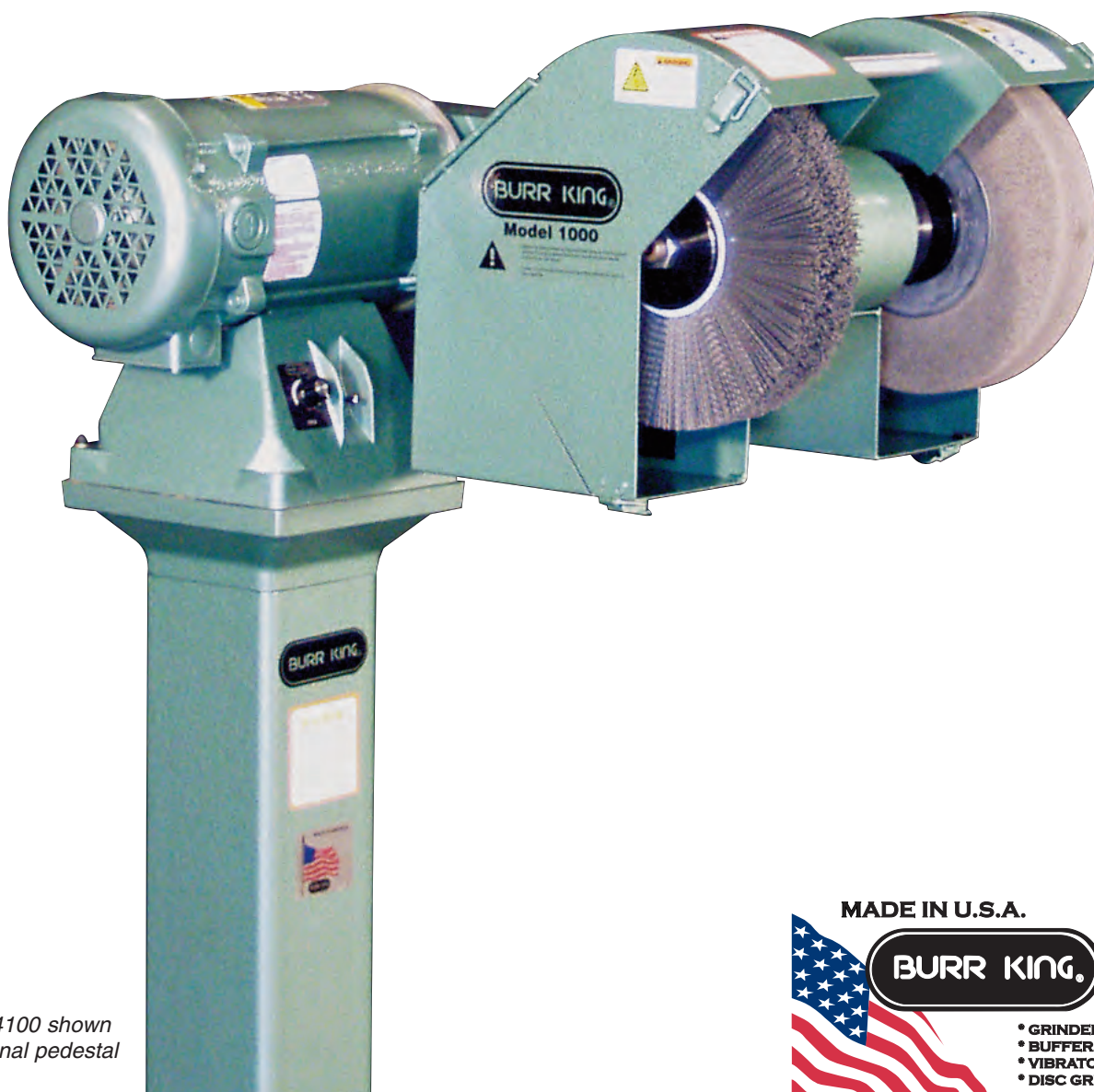

*Model 14100 shown
with optional pedestal*

MADE IN U.S.A.



BURR KING.

- GRINDERS
- BUFFERS
- VIBRATORY
- DISC GRINDERS

BURR KING MODEL 1000

DEBURRING & POLISHING MACHINES

Distributed by: **Trick-Tools.com**

Trick-Tools
80 Truman Road
Pella, IA 50219

Phone:1-877-VAN-SANT
E-mail: sales@trick-tools.com



Here at Trick Tools we believe that our customers deserve the best value in their tool and equipment purchases. We are constantly at work searching out a variety of high quality, high performance tools to offer at the best prices possible. Our commitment to you is that we will not offer “cheap junk” anywhere on our website. You, the customer, help us to evaluate our products constantly and as soon as an ongoing quality issue is uncovered we will correct it or discontinue that product immediately. We hope to earn your continued trust.



June, 2007

Burr King Manufacturing Company, Inc. warrants the below product to be free in material and workmanship. The period of warranty is 1 year (90 days for vibratory bowls of 20 quart and lesser volume) from the date of purchase. No warranty is provided for products that have been modified, abused, handled carelessly, where repairs have been made or attempted by others, or for freight damage. No warranty is provided for three phase electric motors, controllers, etc. when the motors, controllers are not protected by magnetic starters that were supplied and installed by Burr King Manufacturing Company, Inc. No other warranty, written or verbal is authorized by Burr King Manufacturing Company, Inc.

During the warranty period Burr King Manufacturing Company, Inc (or its authorized suppliers or agents) will replace or repair the below product without charge if the product is found by Burr King Manufacturing Company, Inc. to be defective. To receive warranty services you must contact Burr King Manufacturing Company, Inc. and receive authorization for warranty service. Unless otherwise authorized by Burr King Manufacturing Company, Inc. Products (see * below) must be returned to the factory to receive warranty service.

*Motors, speed controllers, and certain other accessories are warranted by their respective manufactures. To receive warranty service on these items you must contact a brand label service center that supports the product in need of service. Burr King Manufacturing Company; Inc. will assist you in locating a service center.

For the first thirty days after purchase, and when Burr King Manufacturing Company, Inc. authorizes warranty service, we will pay normal and necessary surface freight charges both ways (except for items in *). After thirty days the customer is responsible for all freight charges. Where possible Burr King Manufacturing Company, Inc. may elect to make on site service and/or repairs necessary to return the product to serviceable condition.

To assure prompt warranty service it is necessary that you complete and return the below warranty information to Burr King Manufacturing Company, Inc. please **FAX** or **MAIL** at your convenience.

Product model: _____ Serial number: _____
Date Purchased: _____ Purchased from: _____
Address: _____ City: _____ State/Prov: _____ Postal code _____

Your company name: _____
Address: _____ City: _____ State/Prov: _____ Postal code _____
Phone: _____ Fax: _____ Email: _____
Your name: _____ Title: _____

How did you learn about Burr King products?
Trade show ___ Web ___ Industrial Distributor ___ Advertisement ___ Other _____ Which one: _____
What is the intended use of this product? _____

Please indicate the general work types performed at your company, check all that apply:

Fabrication ___ Machining ___ Casting ___ Molding ___ Welding ___ Finishing ___ Assembly ___ Research ___ Other ___

Please indicate the primary product focus of your company; check all that apply.

Aircraft/Missile ___ Automotive ___ Contract machine ___ Contract Fabrication ___ Agricultural ___ Maintenance ___ Recreational ___
Job shop ___ Foundry ___ Construction ___ Arts ___ Orthopedic ___ Dental ___ Medical ___ Other _____

Please tell us what we can do to improve our products:

May we contact you? Yes ___ No ___

Thank you for purchasing Burr King products!

**REGISTER ONLINE @
WWW.BURRKING.COM**



February 2005

OPERATOR, and OPERATING AREA SAFETY

Subject equipment includes Grinders, buffers, polishers, and other rotating equipment. Serious injury or death may occur if minimum safety precautions are not understood, and obeyed by operators and those other persons who may be in the immediate vicinity of the subject equipment. Persons who operate, or are in the immediate vicinity of the subject equipment must be properly trained in, and use, minimum safety precautions and procedures for such machinery.

Minimum safety requirements to operate, or work in the immediate vicinity subject equipment:

1. Read and understand all operating instructions, manuals, labels, and other information provided with the equipment.
2. Install the equipment according to manufacturer's instructions.
3. Securely bolt the equipment to a rigid, structurally sound mounting surface.
4. Use and wear proper eye and face protection.
5. Use and wear proper protection for the body, hands, fingers, feet, and legs.
6. Review and understand all machine guards, adjustments, and points of exposure to potential injury.
7. Do not remove, tamper with, or otherwise alter, equipment guards, and other safety features.
8. Insure the machine is adjusted, and remains adjusted according to manufacture's requirements.
9. Maintain the equipment in good operating condition.
10. Have another person who is knowledgeable in proper and safe operation of the subject equipment demonstrate proper and safe operation to all operators, and to those persons who might be in the immediate vicinity of the subject equipment.
11. Use work piece holding devices when ever possible that diminish the possibility that persons will come in contact with moving machine pieces, or spark/debris output from the machine.
12. Use spark and debris arresting apparatus. Such apparatus should be connected to the machine so as to contain dust and debris that is generated, and to suppress sparks thereby limiting human inhalation risk, and the risk of fire or explosion.
13. Use appropriate inhalation apparatus to protect person from ingestion and/or inhalation of sparks, debris, smoke, particulates, etc.
14. Avoid mixing different metals, alloys, and materials. To mix such materials might create a fire or explosion hazard.
15. Protect persons from work pieces, particulates, etc. that could be forcibly ejected from the machine. For example, a buffing wheel or grinding belt can "grab" a work piece while the work piece is being buffed, polished, ground, or otherwise conditioned, resulting in forcible ejection toward the operator or those in the vicinity of the machine. The use of leather aprons, gloves, and eye shields are examples of protective gear that may be effective. In general do not grind, buff, or otherwise engage the traveling belt, wheel, or disc surface with the work piece pointing into the direction from which the belt, wheel, or disc is traveling. However, if you choose to do so be aware the work piece may lodge in the traveling belt, wheel, or disc and be forcibly, and dangerously ejected.
16. Do not operate this machine if the gap (nip point) between a moving belt, wheel or disc and the work support surface exceeds 1/8 inch.
17. Do not operate this machine if the gap between the moving abrasive belt, disc or wheel and the adjacent face

Continued from page 1

of the work rest (or table) will permit passage of the work piece through the gap (nip point). Note, however, that certain alloys such as titanium may create conditions where grinding debris can accumulate in a tight gap creating a potential fire hazard. **When in doubt consult with your safety officer.** Failure to observe this warning may result in the work piece or other item being caught in this gap, and/or being forcibly ejected. Failure to heed this warning may cause serious bodily harm to the operator and/or bystanders. **NEVER USE THIS EQUIPMENT IF YOU ARE NOT PROPERLY TRAINED IN ITS OPERATION and/or SAFE USE! IF IN DOUBT STOP and ASK FOR GUIDANCE!**

18. Never position the work rest table at an acute angle between the top of the work rest table and the moving belt or wheel. Doing so will create “nip point” that can cause serious injury should an operator body part become entangled (pulled into) the nip point created by this acute angle.

19. Do not operate the equipment, or allow others to operate the equipment without proper training in these and other rotating machinery safety requirements.

20. Do not perform maintenance on the equipment unless you are fully qualified to do so, and understand all necessary safety and operating requirements.

21. Do not leave the machine unattended while it is running.

22. Correct equipment or safety problems immediately. Do not operate the equipment when it requires maintenance, or correction.

23. Install and use high quality abrasive belts, wheels, discs, media, etc., as appropriate to your machine. Understand and follow the operating requirements provided by the manufacturer of these materials.

Rotational Speed Warning, Contact Wheels

Scope: Contact wheels manufactured by Burr King Manufacturing Company, Inc., which have rubber or urethane tires. Examples include but are not limited to stock codes 202, 302, 402, 502, 702, 802, 902, 1002, 1202 and variants. Variants have stock codes that begin with the base number; i.e. 802-S-55 is an 802 variant.

Users are warned not to exceed the below listed revolutions per minute (RPM) on the subject wheels. Failure to heed this warning may lead to tire de-bonding, fragmentation, or other mechanical failure. Such failures may cause serious personal injury to operators or bystanders, and/or cause property damage. All Burr King products are warranted for various time periods to be free of material and/or workmanship defects. Burr King Manufacturing Companies standard warranty policy is summarized as follows for contact wheels. 1 year from date of purchase if mounted on a Burr King machine purchased on the same date or 90 days if purchased as a spare or replacement part. Our warranty does not apply to wheels that are mounted on products not manufactured by Burr King Manufacturing Company, Inc. Users who mount Burr King manufactured contact wheels on product not manufactured by Burr King Manufacturing Company, Inc. do so at their own risk and assume all liability for having so mounted the contact wheel(s).

Remember good safety practice demands guarding to protect operators and bystanders from wheel failure and/or debris. Never use the subject contact wheels without proper guarding that meets commonly accepted safe practice. See OSHA, U/L, CSA, CE, ISO and other respected safety standards.

<u>Stock code</u>	<u>Maximum Safe RPM</u>
202, 302	10000
402, 502, 702 802	4400
902, 1002	2200
1202	1600

Continued from page 2

Occupational Noise Exposure

Burr King products produce levels of noise consistent with their intended purposes. The level and spectral content of noise produced is dependent on the product type, the degree that the product is maintained in proper operating condition, the abrasive/media and accessories used, the specific application, and the surrounding environment. Noise levels produced by various Burr King grinders and polishers, as measured at the Burr King factory, range from 80 to 93 decibels. Product operators and persons in the immediate product vicinity should be protected from excessive noise does levels as prescribed in OSHA regulation 29, piece 1910.95 titled "Occupational Noise Exposure".

ROTATING EQUIPMENT CAN BE DANGEROUS TO OPERATORS AND THOSE WHO MAY BE IN ITS IMMEDIATE OPERATING VICINITY. IT IS THE ABSOLUTE AND DIRECT RESPONSIBILITY OF PURCHASERS, MANAGERS, AND OPERATORS OF THIS EQUIPMENT TO UNDERSTAND AND OBEY THE FOREGOING MINIMUM OPERATING SAFETY REQUIREMENTS. IF YOU HAVE QUESTIONS OR SAFETY CONCERNS REGARDING OPERATING THE SUBJECT EQUIPMENT PLEASE CALL YOUR AUTHORIZED BURR KING DISTRIBUTOR, OR BURR KING MANUFACTURING AT 1-800-621-2748. YOUR SAFETY IS OUR FOREMOST CONCERN!

Burr King Manufacturing disclaims any and all responsibility for injuries, damage, loss of income, or other adverse consequence as might be incurred by purchasers, managers, and operators of this equipment.

Page 3 is last page



June 2007

Operating instructions for the Model 1000 buffer

The Model 1000 buffer is a double spindle buffer. It is designed to use cotton, nylon, flap, wire, and other buffing and/or de-burring wheels. Your Model 1000 may be fixed speed (single or three phase), or variable speed single phase depending on the configuration ordered. The Model 1000 has an integrated dust collection adapter that will connect to a dust collection system with a recommended minimum capacity of 500 CFPM.

Stone, vitreous, or other type grinding wheels must not be used on the Model 1000. For maximum effectiveness, and operator safety use wheels manufactured by well-respected manufacturers.

- Use wheels that are the proper size and type for your machine.
- Do not use wheels that are old and/or excessively worn.
- Do not operate the buffing wheel in a reverse rotation. The spindle must rotate CCW when viewed from the right side (opposite of the motor).
- Do not exceed the maximum recommended buffing wheel speed (see the manufacture's instructions), or the 2000 RPM spindle speed for which your Model 1000 is designed to operate, which ever is less.
- Do not use your Model 1000 with the factory-supplied guards removed, or with the wheel guard door(s) open.

Prior to operating the Model 1000 please take time to do the following:

1. Insure that you have received all of the items that you ordered. Compare the packing slip with your purchase order, and of course with the physical items received.
2. Verify that there is no obvious shipping damage. If shipping damage is discovered notify the freight carrier of your intention to file a freight damage claim; they will assist you.
3. Verify that the AC power that is identified on the machine matches the AC power that you intend to operate the machine. Do not modify the Model 1000 wiring or other electrical controls without the advice of the factory or a competent electrician.
4. Do not modify or defeat any AC wiring safety feature. In example, do not remove the grounding pin on the AC plug.
5. Read the Operator, and Operating Area Safety Instructions carefully. Insure that all persons who will operate the Model 1000, or who will work in the vicinity of the Model 1000 read, understand, and comply with these instructions.

6. Insure that the Model 1000 is located in an area that provides safe access to the machine such that operators have clear and unobstructed working space. The work place should be free from floor obstructions, trip points, and other faults that may reduce operator safety.

7. Insure that the Model 1000 AC power source is properly sized for wire, and properly fused. As a guide the following electrical service will reliably operate your 1.5 HP Model 1000 (you should consult a competent electrician):

<u>Service</u>	<u>Minimum wire size</u>	<u>Maximum fuse size</u>
120VAC/1PH	12AWG copper	20 Ampere fast
220VAC/1PH	12AWG copper	10 Ampere fast
220VAC/3PH	12AWG copper	7 Ampere fast
440VAC/3PH	12AWG copper	3 Ampere fast

8. All three phase electrical installations should include a magnetic starter. Magnetic starters protect motors from “double phasing”, overheating, etc. thereby reducing the risk of damage to the equipment and/or fire hazard to your facility.

9. Variable speed 1.5 HP/1PH motors include line fuses that are built into the rear of the base that supports the motor. 120VAC/1PH variable speed motors use 25 ampere fast blow fuses, 220VAC/1PH variable speed motors use 15 ampere fast blow fuses. Fixed speed motors should have proper fuses used in the customer’s supply circuitry (see 7 above). NEVER use fuses that are of greater amperage than listed. To do so may create a fire hazard, or equipment damage.

Functional operating instructions for the Model 1000 buffer

The Model 1000 was fully tested and verified to comply with requirements prior to shipping from the factory. No adjustments should be necessary. You should perform the following steps:

1. With the machine securely bolted to its table, pedestal, and/or floor point connect the AC power to its source.
2. Insure the buffing wheels are firmly tightened to the spindle. A buffing wheel running in reverse rotation can unscrew from the spindle, creating a serious personnel safety hazard. Insure that the Model 1000 spindle operates CCW when viewed from the right side of the machine. Note that the left spindle has a left-hand thread that assures the left buffing wheel will not spin off of the machine during correct rotation of the spindle. The right spindle has a right-hand thread.
3. Your model 1000 has been shipped to you with 2 cap plugs on each end of the spindle it is very important that once you have selected the wheel you will be using on your machine that you cut the plug to the size of the exposed thread. Failure to do so may expose the operator to risk of injury should clothing or loose objects become snagged on the exposed area.
4. Engage the motor by placing the ON/OFF switch to ON. The wheel should rotate smoothly in a CCW direction with the front face of the buffing wheel moving toward the floor. If either of these conditions are not met turn the machine OFF immediately.

If the Model 1000 runs in reverse direction you must correct this by changing the main drive motor rotation direction. **FIRST DISCONNECT THE MACHINE FROM ITS AC POWER SOURCE. A COMPETENT ELECTRICIAN SHOULD PERFORM ALL ELECTRICAL WORK ON THE MODEL 1000.**

All single phase Model 1000 buffers are set up for correct rotation at the factory. The phasing of your “in-house” electric service will effect three phase Model 1000 rotation.

- 1) Reverse the motor direction of a fixed speed three-phase motor by reversing any two legs of the input power lines.
- 2) Reverse the motor direction of a fixed speed single phase motor by reversing leads 5 and 8 found within the metal wiring box located on the motor, or as otherwise instructed on the actual motor label.
- 3) Reverse the direction of a variable speed motor by following the instructions supplied with the motor.

If your Model 1000 is equipped with variable speed control the wheel speed can be adjusted using the speed control that will be mounted on the motor or on a separate control box.

If your Model 1000 is fixed speed, or variable speed turn the machine ON or OFF using the controls provided, or by using the controls that are provided in your or by Burr King magnetic starters, etc.

Maintenance

FIRST DISCONNECT THE MACHINE FROM ITS AC POWER SOURCE.

Every thirty days or if the drive belt slips check the drive belt tension To adjust the belt tension:

- Remove the two screws that secure the aluminum cover plate on the right side of the main casting. This plate bears the mark “Model 1000”.
- Loosen (do not remove) the two elastic nuts (use a 9/16 inch socket) inside the main frame near the rear drive pulley. Use care not to nick or otherwise damage the pulley. The pulley has a series of shallow groves that drive the Micro-V flat drive belt. Any damage to the groves will shorten belt life significantly.
- Pull the main frame forward in respect to the motor. The frame will slide across the motor face with the above elastic nuts loose.
- The belt is properly tensioned when a force of approximately 5 pounds will deflect the belt approximately ¼ inch near the center of the belt track.
- Tighten the two elastic nuts and reinstall the cover plate.

Vacuum or otherwise remove dust and debris build-up regularly from the machine,

There are no other maintenance actions required. All bearings are sealed for life and require no lubrication.

Remember for operator safety and the continued effectiveness of your Model 1000:

Do not defeat the safety guards and other safety provisions of the Model 1000.

Do not reach inside the safety guards while the machine is running. To do so is hazardous.

Do not use fluids in your buffing process unless your Model 1000 is designed for liquid operation (NEMA 4, 4X). To do so may create an electrical safety hazard.

Do not use your Model 1000 to polish explosive materials unless it is equipped with explosion proof electrical devices and motor.

Do not mix alloys in your buffing. To do so may create an explosion hazard.

Do not use stone or vitreous wheels on the Model 1000. To do so will create an operator safety hazard.

Do use eye, hand, face, arm, leg, feet and body protection that is adequate to protect against flying debris, forcibly ejected work pieces, etc.

Do not wear loose fitting, or hanging clothing that might become entangled in the rotating wheels, or shafts.

Do train operators and others in safe operating practices.

Post these or equivalent instructions such they are available for ready operator reference.

1000/ 1200

PARTS LIST

BURR KING

1220 TAMARA LANE
WARSAW, MO. 65355

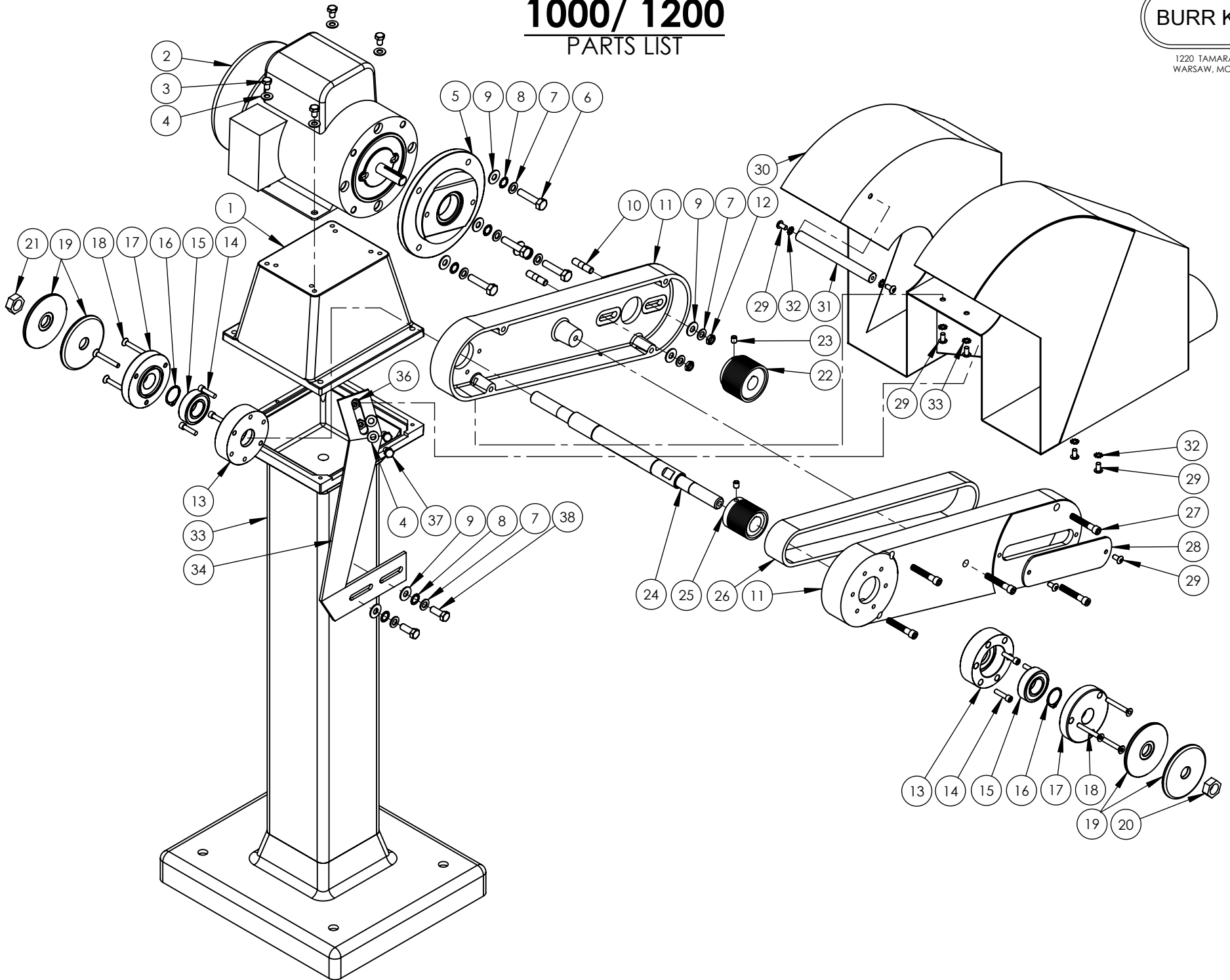

1000/ 1200			
ITEM NO.	PART NUMBER	DESCRIPTION	QTY.
1	941	BASE	1
2	MOTOR	CALL FACTORY	1
3	2	BOLT, 5/16-18x1 1/2 HEX HEAD	4
4	4	WASHER, 5/16 SAE ZINC PLTD	6
5	908-1	ADPTER, C-FACE	1
6	1-0003	BOLT, 3/8-16 x 1 1/4 HEX HEAD	4
7	17	WASHER, 960-616, AN	8
8	5-0014	WASHER, LOCK 3/8, INTERNAL STAR	6
9	42	WASHER, SAE, 3/8	8
10	920	STUD 3/8"x1 1/2", DOUBLE	2
11	1026	FRAME, ASSEMBLY	1
12	39	NUT, 3/8-24, JAM, ESNA, NTE	2
13	1033	MOUNT, BEARING	2
14	2-0026	SCREW, 1/4-28 x 1, ALLEN CAP	6
15	11-0004	BEARING	2
16	10-0003	CIRCLIP, 1.0 DIA	2
17	1034	SHROUD, BEARING MOUNT	2
18	1-0021	SCREW, 1/4-28 x 1-3/4, ALLEN	6
19	1030	FLANG, WHEEL	4
20	1031	NUT, 3/4 x 16 RH, HEX	1
21	1032	NUT, 3/4 x 16 LH, HEX	1
22	*20-0007 *20-0013	PULLEY, MICRO-V, 16G 2.4 x .875 PULLEY, 8 GROOVE/J, 2.5D x .984	1
23	25	SCREW, SET, 5/16-18 X 3/8, ALLEN	2
24	1028	SHAFT	1
25	*20-0008 *20-0014	PULLEY, MICRO-V, 16G 1.98 x .984 PULLEY, 8 GROOVE/J, 2D x 5/8	1
26	*1039 *1039-1	BELT, MICRO-V, 16 GROOVE, 360J16 BELT, MICRO-V, 8 GROOVE, 360J8	1
27	2-0027	SCREW, 5/16-18 x 2, SHCS	5
28	1035	PLATE, LOGO	1
29	2-0028	SCREW, 1/4-28x1/2 BH, BLK OX	8
30	1029	GUARD	1
31	1037	SUPPORT, GUARD, CENTER	1
32	5-0008	WASHER, 1/4, LOCK, EXTERNAL	6

1200 ONLY			
ITEM NO.	PART NUMBER	DESCRIPTION	QTY.
33	*02	PEDESTAL, BK-746	1
34	*1042	SUPPORT, GUARD, PEDESTAL	1
35	4-0014	NUT, 3/8-16, ELASTIC LOCK GD 2	2
36	37	BOLT, 5/16-18x3/4 HEX HEAD	2
37	1-0042	BOLT, 3/8-16 x 1 1/4 HEX HEAD	2

NOTE:

*20-0007 & 20-0008
*20-0013 & 20-0014

2&3 HP/ 3PH
1-1.5 HP/ 1PH

*1039
*1039-1

2&3 HP/ 1&3 PH
1-1.5 HP/ 1PH

*1042

ONLY FOR 1200

*02

OPTIONAL 1000
STANDARD 1200

MAG STARTER

PARTS LIST

BURR KING

1220 TAMARA LANE
WARSAW, MO. 65355

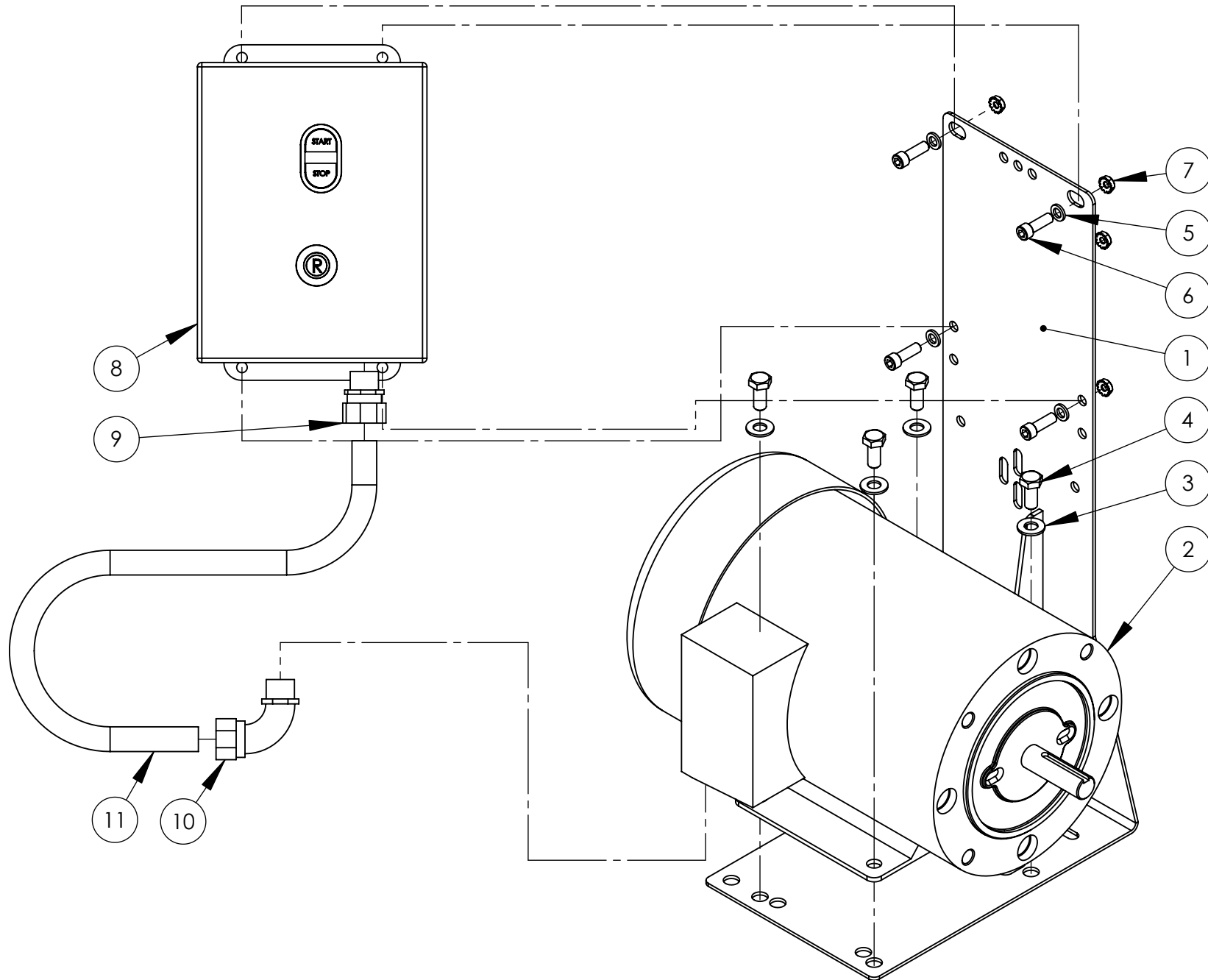

MAG STARTER			
ITEM NO.	PART NUMBER	DESCRIPTION	QTY.
1	MB-4C	BRACKET, MOUNTING, STARTER	1
2	MOTOR	CALL FACTORY FOR PART NUMBER	1
3	4	WASHER, 5/16 SAE ZINC PLTD	4
4	37	BOLT, 5/16-18x3/4 HEX HEAD	4
5	5	WASHER, 1/4 AN	4
6	209	SCREW, 1/4-20 X 3/4 ALLEN HEAD	4
7	4-0013	NUT, KEP, 1/4-20	4
8	MS2A3 MS4A3 MS2B3 MS4B3	3/4HP-1HP, 220V 3/4HP-1HP, 440V 1.5HP-3HP, 220V 1.5HP-3HP, 440V	1
9	775	CONNECTOR, 3/8", STR, LIQ. TIGHT	1
10	776	CONNECTOR, 3/8", 90 DEG, LIQ. TIGHT	1
11	020	CONDUIT 3/8" LIQUID TIGHT	1

VARI SPEED

SINGLE PHASE

BURR KING

1220 TAMARA LANE
WARSAW, MO. 65355

3/4-1 HP

1.5-3 HP

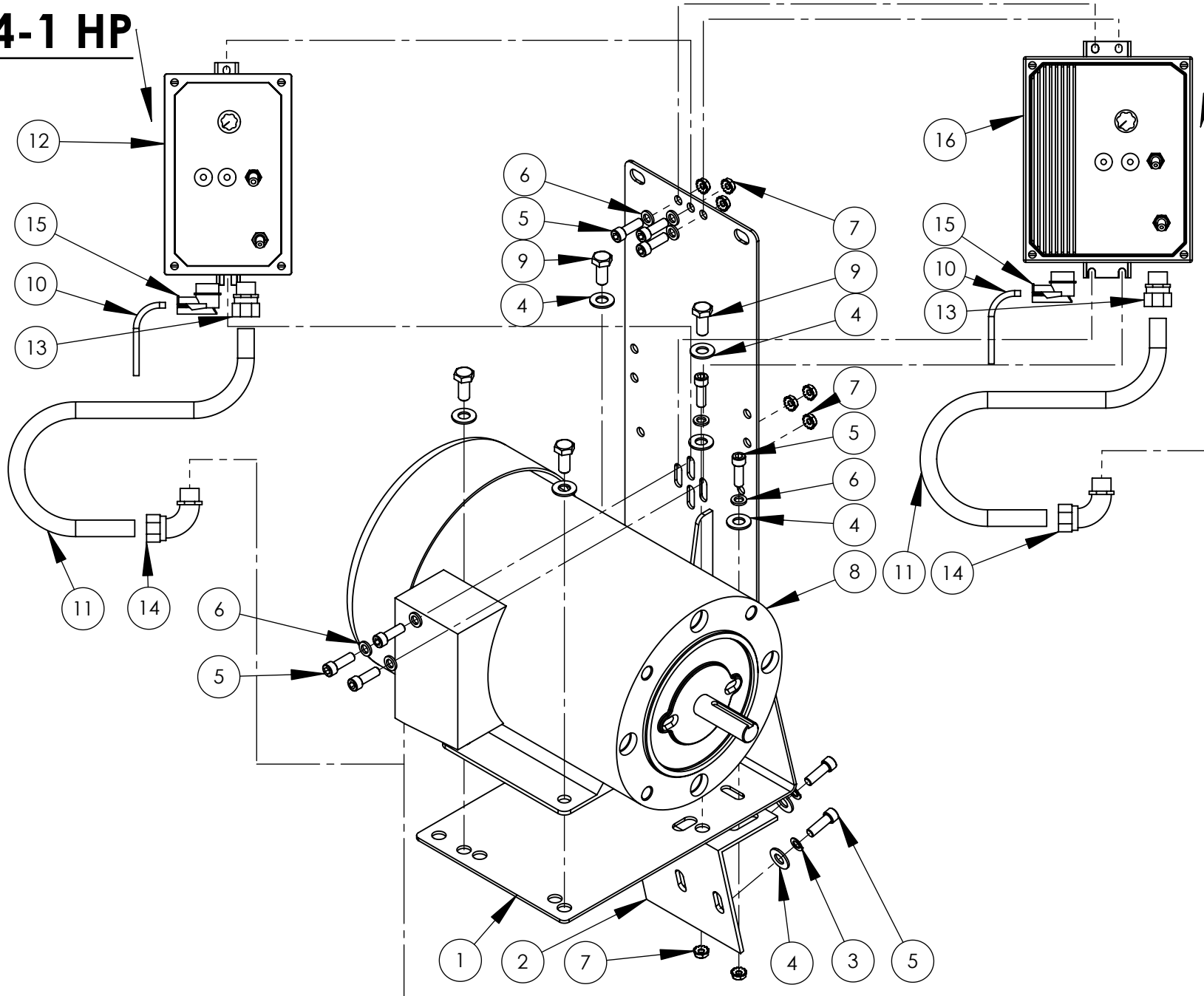

VARI SPEED			
ITEM NO.	PART NUMBER	DESCRIPTION	QTY.
1	MB-4C	BRACKET, MOUNTING, STARTER	1
2	941-3	BRACE, MB4 SUPPORT	1
3	5-0032	WASHER, 1/4, LOCK, SPLIT, PLTD	2
4	4	WASHER, 5/16 SAE ZINC PLTD	8
5	209	SCREW, 1/4-20 X 3/4 ALLEN HEAD	10
6	5	WASHER, 1/4 AN	8
7	4-0013	NUT, KEP, 1/4-20	8
8	100B-1725C 150B-1725C	1 HP MOTOR 1.5 HP MOTOR	1
9	37	BOLT, 5/16-18x3/4 HEX HEAD	4
10	015-1 017	120V CORD 220V CORD	1
11	020	CONDUIT 3/8" LIQUIDTIGHT	1
12	864-1	CONT. 115/220V 0.75-1HP	1
13	775	CONNECTOR, 3/8" STR, LIQ. TIGHT	1
14	776	CONNECTOR, 3/8", 90 DEG, LIQ. TIGHT	1
15	643	RELIEF, STRAIN 3/8" 90 DEG	1
16	862-3	CONT. 115/220V 1.5-3HP	1

NOTE

FOR 3 PHASE CONTROLLER CALL FACTORY.

CE CERTIFICATION PART NUMBERS

ADD TO CONTROLLER

ITEM NO.	PART NUMBER	DESCRIPTION	QTY.
12	9974-6	LINE FILTER	1
16	9974-5	LINE FILTER	1
CHANGE PART			
15	3356	RELIEF, STRAIN	1
10	CE CORD	NO PLUG- CUSTOMER INSTALLED PLUG	1