

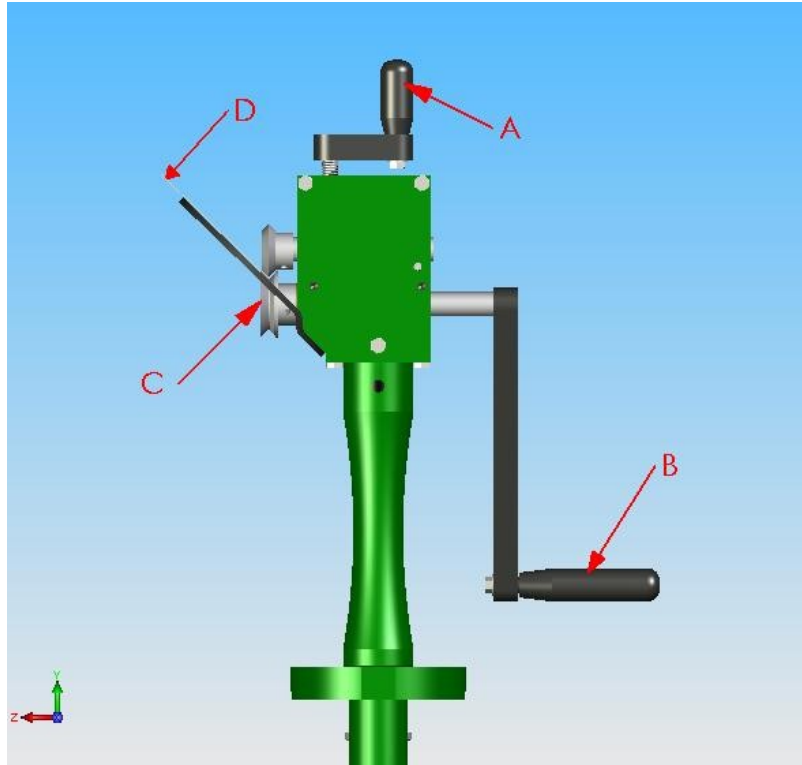

## RAMS-2002 HAND FLANGER

Capacity 20 Ga. Mild Steel Maximum



### OPERATION:

Place the edge of material in slot (D) located at the top of the guide plate and bend edge of material down to create a “starter” flange. Now that material has starter flange, place material in between two rollers. Adjust handle (A) down and then crank handle (B) while feeding material into groove on the bottom roll (C) and complete to desired profile.

\*See product video for more information.

### NOTE:

- The edge of the material must seat against groove (C) in the lower forming roll, to obtain satisfactory height and formed flange. Irregular height or heavy wrinkle flange can be caused by improper pressure.
- On exceptionally small curves, the edge might wrinkle. When this occurs, run through a second time.

## MAINTENANCE:

1. Keep rollers clean and free of galvanized deposits.
2. Occasionally spray rollers with WD-40.

Distributed by: **Trick-Tools.com**



Trick-Tools  
80 Truman Road  
Pella, IA 50219

Phone: 1-877-VAN-SANT  
E-mail: [sales@trick-tools.com](mailto:sales@trick-tools.com)

