

JET[®]

Operating Instructions and Parts Manual Horizontal Band Saw Models HBS-916W; HBS-1018W



WALTER MEIER (Manufacturing) Inc.

427 New Sanford Road
LaVergne, Tennessee 37086
Ph.: 800-274-6848
www.waltermeier.com

Part No. M-414468

Revision G1 06/2010

Copyright © 2010 Walter Meier (Manufacturing) Inc.

Warranty and Service

Walter Meier (Manufacturing) Inc., warrants every product it sells. If one of our tools needs service or repair, one of our Authorized Service Centers located throughout the United States can give you quick service. In most cases, any of these Walter Meier Authorized Service Centers can authorize warranty repair, assist you in obtaining parts, or perform routine maintenance and major repair on your JET® tools. For the name of an Authorized Service Center in your area call 1-800-274-6848.

MORE INFORMATION

Walter Meier is consistently adding new products to the line. For complete, up-to-date product information, check with your local Walter Meier distributor, or visit waltermeier.com.

WARRANTY

JET products carry a limited warranty which varies in duration based upon the product (MW = Metalworking, WW = Woodworking).

90 DAY WARRANTY	1 YEAR WARRANTY	2 YEAR WARRANTY	3 YEAR WARRANTY	5 YEAR WARRANTY	LIFE LIFETIME WARRANTY
Lathe Accessories Machine Accessories Mobile Bases Safety Equipment Specialty Items Vise Accessories	Air Tools- Contractor Air Tools-Industrial Air Tools-Light Industrial Lubrication	Body Repair Kits Bottle Jacks Cable Pullers Cold Saws Hoists-Air Hoists-Electric Metal forming Mill/Drills Milling Machines MW Bandsaws MW Drill Presses MW Finishing Equipment MW Lathes MW Precision Vises	Palet Trucks Rigging Equip. Service Jacks Stackers Surface Grinders Tapping Trolleys-Air Trolleys-Electric Web Slings Winches-Electric	Beam Clamps Chain Hoist- Manual Lever Hoists Pullers-JCH Models Scissor Lift Tables Screw Jacks Trolleys-Geared Trolleys-Plain Winches-Manual WW Air Filtration WW Bandsaws WW Buffers	WW Drill Presses WW Dust Collectors WW Dust Filters WW Dust Fittings WW Jointers WW Lathes WW Planers WW Sanders WW Shapers WW Tablesaws
<small>Warranty reverts to 1 Year Warranty if woodworking (WW) products listed above are used for industrial or educational purposes.</small>					

WHAT IS COVERED?

This warranty covers any defects in workmanship or materials subject to the exceptions stated below. Cutting tools, abrasives and other consumables are excluded from warranty coverage.

WHO IS COVERED?

This warranty covers only the initial purchaser of the product.

WHAT IS THE PERIOD OF COVERAGE?

The general JET warranty lasts for the time period specified in the product literature of each product.

WHAT IS NOT COVERED?

Five Year Warranties do not cover woodworking (WW) products used for commercial, industrial or educational purposes. Woodworking products with Five Year Warranties that are used for commercial, industrial or education purposes revert to a One Year Warranty. This warranty does not cover defects due directly or indirectly to misuse, abuse, negligence or accidents, normal wear-and-tear, improper repair or alterations, or lack of maintenance.

HOW TO GET SERVICE

The product or part must be returned for examination, postage prepaid, to a location designated by us. For the name of the location nearest you, please call 1-800-274-6848.

You must provide proof of initial purchase date and an explanation of the complaint must accompany the merchandise. If our inspection discloses a defect, we will repair or replace the product, or refund the purchase price, at our option. We will return the repaired product or replacement at our expense unless it is determined by us that there is no defect, or that the defect resulted from causes not within the scope of our warranty in which case we will, at your direction, dispose of or return the product. In the event you choose to have the product returned, you will be responsible for the shipping and handling costs of the return.

HOW STATE LAW APPLIES

This warranty gives you specific legal rights; you may also have other rights which vary from state to state.

LIMITATIONS ON THIS WARRANTY

WALTER MEIER (MANUFACTURING) INC., LIMITS ALL IMPLIED WARRANTIES TO THE PERIOD OF THE LIMITED WARRANTY FOR EACH PRODUCT. EXCEPT AS STATED HEREIN, ANY IMPLIED WARRANTIES OR MERCHANTABILITY AND FITNESS ARE EXCLUDED. SOME STATES DO NOT ALLOW LIMITATIONS ON HOW LONG THE IMPLIED WARRANTY LASTS, SO THE ABOVE LIMITATION MAY NOT APPLY TO YOU.

WALTER MEIER SHALL IN NO EVENT BE LIABLE FOR DEATH, INJURIES TO PERSONS OR PROPERTY, OR FOR INCIDENTAL, CONTINGENT, SPECIAL, OR CONSEQUENTIAL DAMAGES ARISING FROM THE USE OF OUR PRODUCTS. SOME STATES DO NOT ALLOW THE EXCLUSION OR LIMITATION OF INCIDENTAL OR CONSEQUENTIAL DAMAGES, SO THE ABOVE LIMITATION OR EXCLUSION MAY NOT APPLY TO YOU.

Walter Meier sells through distributors only. The specifications in Walter Meier catalogs are given as general information and are not binding. Members of Walter Meier reserve the right to effect at any time, without prior notice, those alterations to parts, fittings, and accessory equipment which they may deem necessary for any reason whatsoever. JET®-branded products are not sold in Canada by Walter Meier.

Table of Contents

- Warranty and Service2
- Table of Contents.....3
- Warning.....4
- Introduction.....6
- Specifications.....6
- Uncrating and Cleanup.....7
- Installation.....7
- Assembly7
- Electrical Connections.....8
- Controls.....9
- Prior to Operation9
- Adjustments.....10
 - Adjusting Vise Square to the Blade10
 - Changing Blade Speeds.....10
 - Adjusting Feed Rate.....11
 - Changing Blades.....11
 - Blade Tracking Adjustment12
 - Automatic Shut-Off Adjustment.....13
 - Thrust Roller Adjustment.....13
 - Guide Roller Adjustment.....13
 - Bow Weight Adjustment.....14
 - Vise Adjustment.....14
- Maintenance.....15
- Lubrication.....15
- Replacement Parts.....15
 - Base and Bed Assembly16
 - Saw Arm Assembly – HBS-916W.....17
 - Saw Arm Assembly – HBS-1018W.....18
 - Parts List for HBS-916W, HBS-1018W19
 - Gear Speed Reducing Box Assembly26
 - Parts List for Gear Speed Reducing Box Assembly.....27
- Electrical Connections – HBS-916W28
- Electrical Connections – HBS-1018W.....29



Warnings

1. Read and understand the entire owner's manual before attempting assembly or operation.
2. Read and understand the warnings posted on the machine and in this manual. Failure to comply with all of these warnings may cause serious injury.
3. Replace the warning labels if they become obscured or removed.
4. This band saw is designed and intended for use by properly trained and experienced personnel only. If you are not familiar with the proper and safe operation of a band saw, do not use until proper training and knowledge have been obtained.
5. Do not use this band saw for other than its intended use. If used for other purposes, Walter Meier (Manufacturing), Inc., disclaims any real or implied warranty and holds itself harmless from any injury that may result from that use.
6. Always wear approved safety glasses/face shields while using this band saw. Everyday eyeglasses only have impact resistant lenses; they are not safety glasses.
7. Before operating this band saw, remove tie, rings, watches and other jewelry, and roll sleeves up past the elbows. Do not wear loose clothing. Confine long hair. Non-slip footwear or anti-skid floor strips are recommended. Do **not** wear gloves.
8. Wear ear protectors (plugs or muffs) during extended periods of operation.
9. Some dust created by power sanding, sawing, grinding, drilling and other construction activities contains chemicals known to cause cancer, birth defects or other reproductive harm. Some examples of these chemicals are:
 - Lead from lead based paint.
 - Crystalline silica from bricks, cement and other masonry products.
 - Arsenic and chromium from chemically treated lumber.Your risk of exposure varies, depending on how often you do this type of work. To reduce your exposure to these chemicals, work in a well-ventilated area and work with approved safety equipment, such as face or dust masks that are specifically designed to filter out microscopic particles.
10. Do not operate this machine while tired or under the influence of drugs, alcohol or any medication.
11. Make certain the switch is in the **OFF** position before connecting the machine to the power supply.
12. Make certain the machine is properly grounded.
13. Make all machine adjustments or maintenance with the machine unplugged from the power source.
14. Remove adjusting keys and wrenches. Form a habit of checking to see that keys and adjusting wrenches are removed from the machine before turning it on.
15. Keep belt guard, blade guards, and wheel covers in place and in working order.
16. Always keeps hands and fingers away from the blade when the machine is running.
17. Never hand hold the material. Always use the vise and clamp it securely.
18. Always provide adequate support for long and heavy material.
19. Keep safety guards in place at all times when the machine is in use. If removed for maintenance purposes, use extreme caution and replace the guards immediately after maintenance is complete.
20. Check damaged parts. Before further use of the machine, a guard or other part that is damaged should be carefully checked to determine that it will operate properly and perform its intended function. Check for alignment of moving parts, binding of moving parts, breakage of parts, mounting and any other conditions that may affect its operation. A guard or other part that is damaged should be properly repaired or replaced.



Warnings

21. Provide for adequate space surrounding work area and non-glare, overhead lighting.
22. Keep the floor around the machine clean and free of scrap material, oil and grease.
23. Keep visitors a safe distance from the work area. **Keep children away.**
24. Give your work undivided attention. Looking around, carrying on a conversation and “horse-play” are careless acts that can result in serious injury.
25. Maintain a balanced stance at all times so that you do not fall or lean against the blade or other moving parts. Do not overreach or use excessive force to perform any machine operation.
26. Use the right tool at the correct speed and feed rate. Do not force a tool or attachment to do a job for which it was not designed. The right tool will do the job better and more safely.
27. Use recommended accessories; improper accessories may be hazardous.
28. Maintain tools with care. Keep blade sharp and clean for the best and safest performance. Follow instructions for lubricating and changing accessories.
29. Turn off the machine and disconnect from power before cleaning. Use a brush to remove chips or debris — do not use your hands.
30. Do not stand on the machine. Serious injury could occur if the machine tips over.
31. Never leave the machine running unattended. Turn the power off and do not leave the machine until it comes to a complete stop.

Familiarize yourself with the following safety notices used in this manual:



This means that if precautions are not heeded, it may result in minor injury and/or possible machine damage.



This means that if precautions are not heeded, it may result in serious or even fatal injury.

- - SAVE THESE INSTRUCTIONS - -

Introduction

This manual is provided by Walter Meier (Manufacturing) Inc., covering the safe operation and maintenance procedures for a JET Model HBS-916W or HBS-1018W Band Saw. This manual contains instructions on installation, safety precautions, general operating procedures, maintenance instructions and parts breakdown. This machine has been designed and constructed to provide years of trouble free operation if used in accordance with instructions set forth in this manual. If there are any questions or comments, please contact either your local supplier or Walter Meier. Walter Meier can also be reached at our web site: www.waltermeier.com.

Specifications

Model Number.....	HBS-916W.....	HBS-1018W.....
Stock Number	414468.....	414473.....
Capacity (in.):		
Round at 90°	9.....	10.....
Round at 45°	6-1/8.....	7-3/4.....
Rectangle at 90°	4 x 16 – 9 x 12.....	6 x 18 – 10 x 16.....
Rectangle at 45°	9 x 6-1/8.....	9 x 7-3/4.....
Blade Size (in.)	1 x 0.032 x 119-1/2.....	1 x 0.032 x 130.....
Blade Wheel Diameter (in.).....	13.....	14.....
Blade Wheel Speed (SFPM).....	82, 132, 170, 235.....	82, 132, 210, 330.....
Motor.....	TEFC 1.5HP, 1PH, 115/230V*.....	TEFC 2HP 1PH 230V only.....
	*pre-wired 115V	
Lowered Height (in.).....	41.....	43.....
Raised Height (in.)	65.....	69.....
Bed Height (in.)	25.....	25.....
Overall Dimensions (in.)	65L x 28W.....	70L x 31W.....
Net Weight – approx. (lbs.).....	625.....	776.....
Shipping Weight – approx. (lbs.).....	704.....	864.....

The above specifications were current at the time this manual was published, but because of our policy of continuous improvement, Walter Meier reserves the right to change specifications at any time and without prior notice, without incurring obligations.

Uncrating and Cleanup

Note: Read and understand the entire manual before attempting setup or operation.

1. Finish uncrating the saw and inspect for damage. Should any have occurred, contact your local distributor.
2. Remove all bolts attaching machine to shipping base.
3. Leave packing material between vise clamps and saw head intact until band saw has been lifted to its final position.
4. Clean all rust protected surfaces with kerosene or diesel oil to remove protective coating. Do not use gasoline, paint thinner, mineral spirits, etc. These may damage painted surfaces.
5. Lubricate all slideways with SAE 10W oil.

Installation

For best performance, the band saw should be located on a solid and level foundation. Allow room for servicing and for moving large stock around the band saw when deciding a location for the machine.

1. Using lifting straps that are isolated from the band saw's finished surfaces, lift machine and place in desired location. See Figure 1 for strap placement.
2. Install four leveling bolts with lock nuts on both sides of the base as shown in the parts breakdown on page 16, items 2 and 3.
3. Place a level on the table surface and check side-to-side and front-to-back.
4. Adjust leveling screws until machine is level in both directions and tighten locking nuts.

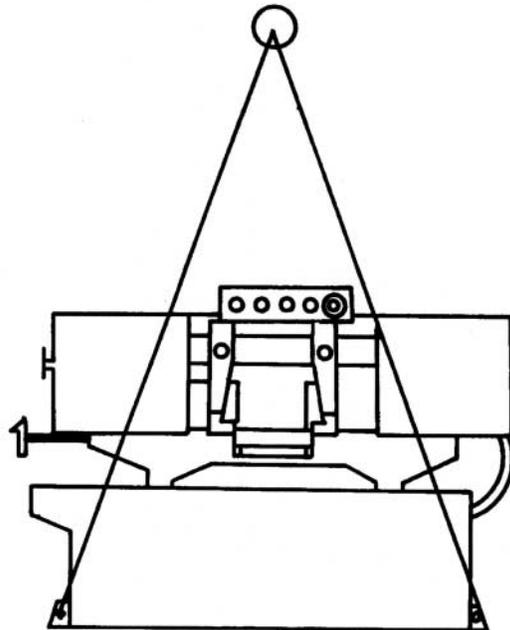
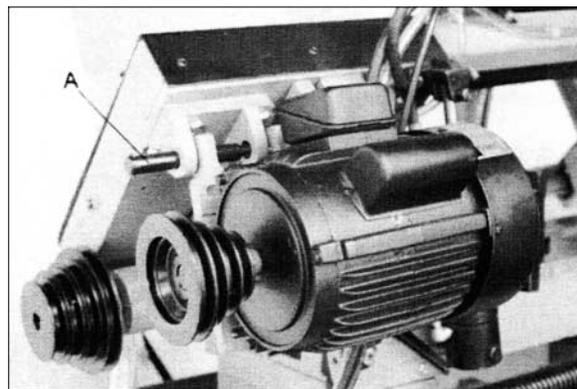

Figure 1

Assembly

1. Unbolt the motor assembly from the shipping crate bottom.
2. Remove nut and washer from the motor support shaft.
3. Remove shaft (A, Figure 2) from the motor mount bracket.



4. Carefully lift motor and line up holes in the motor mounting plate and the motor bracket.
5. Slide motor support shaft into motor mount bracket to hold the motor in place.
6. Fasten shaft with nut and washer.
7. Loosen strain relief nut on the motor junction box. Remove the junction box cover. Insert wire through strain relief and connect to the terminal strip using the diagram on the junction box cover. Tighten the strain relief nut and replace the junction box cover.
8. Remove two hex cap bolts and washers (A, Figure 3) from the right side of the saw arm.
9. Slide belt cover (B, Figure 3) around pulley shafts and attach to saw with two hex cap bolts and two washers.
10. Lift motor and place v-belt around both pulleys. Lower motor.
11. Tension the v-belt by pushing down on the motor and tightening the lock handle on the motor tilt plate. Correct tension is achieved when finger pressure between the two pulleys causes approximately a 1/2" deflection. See Figure 4.
12. Close pulley cover door and fasten with lock knob.
13. Fasten work stop rod (#17, page 16) to saw bed (#11) by inserting into bed and turning clockwise until tight. Place work stop bracket (#16) onto stop rod (#17) and tighten lock handle (#20). Attach stop screw (#19) to stop bracket (#16) with lock handle (#18) and tighten.

Figure 2

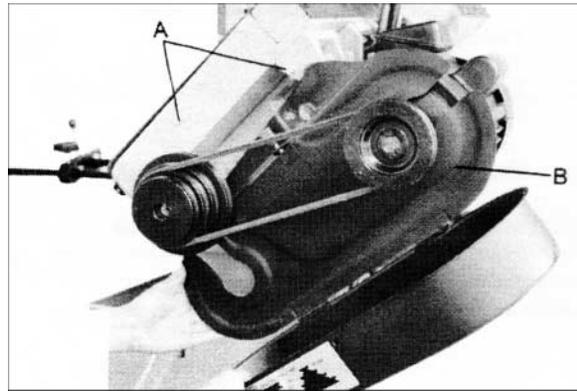

Figure 3

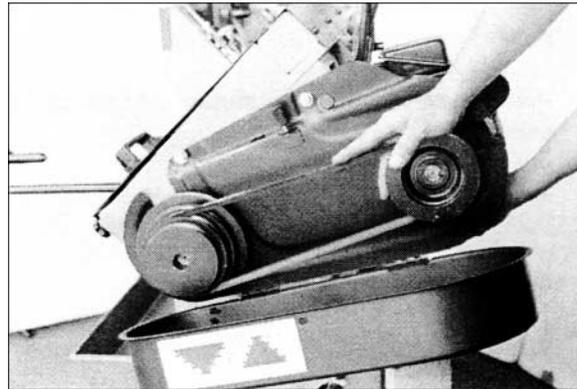

Figure 4

Electrical Connections

⚠WARNING Electrical connections must be made by a qualified electrician in compliance with all relevant codes. This machine must be properly grounded to help prevent electrical shock and possible fatal injury.

Disconnect machine from power source before changing any voltage components!

The HBS-916W Band Saw is rated at 115/230V single phase, and is pre-wired 115 volt from the factory. The HBS-1018W is rated at 230V only, single phase. Confirm that power available at the saw's location matches that for which the saw is wired.

To convert the HBS-916W from 115V to 230V, the following items will have to be changed:

Main Motor – follow diagram inside junction box cover.

Coolant Pump – Remove chip pan on front of saw, remove junction box cover on pump, and follow diagram inside junction box cover.

Control Transformer – Open electrical panel on rear of base and change the fuse from 115V to 230V.

Machine must always be correctly grounded.

NOTE: The power cord end will have to be changed to one rated 230V when changing to the higher voltage.

Controls

Refer to Figure 5.

Power Indicator Light (A) – lit whenever machine is running.

Start Button (B) – press to start band saw.

Emergency Stop Button (C) – press to immediately stop all machine functions.

Coolant Switch (D) – Turn arrow to “I” to turn on coolant flow. Turn arrow to “O” to stop coolant flow.

Cutting Pressure Control (E) – turn clockwise to decrease cutting pressure. Turn counter-clockwise to increase cutting pressure.

Hydraulic On-Off Valve (F) – turns hydraulic cylinder on and off.

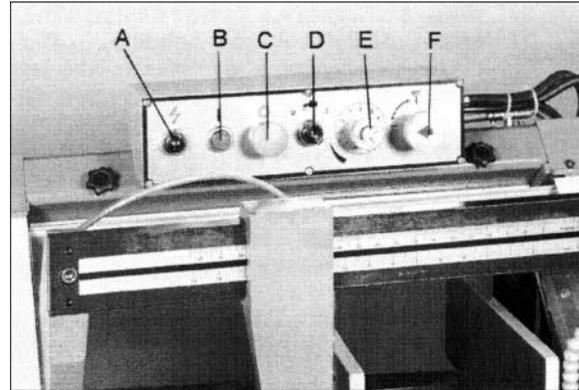

Figure 5

Prior to Operation

1. Check that blade tooth direction matches diagram on blade guides.
2. Check to see that blade is properly seated on wheels after applying correct tension (approximately 25,000 lbs.).
3. Set blade holder guides for approximately .003" to .005" clearance between the guides and blade.
4. Check for slight clearance between back up rollers and back of blade.
5. Position blade guides as close to workpiece as possible.
6. Select proper speed and feed rate for material being cut. See speed selection chart found in the enclosed "Guide to Band Sawing" booklet supplied with this saw.

7. Material to be cut must be securely held in vise.
8. Check to see that coolant level is adequate and turn on coolant pump if material to be cut requires it. Machine should be filled with four gallons of the proper coolant mixture. Follow the directions on the product maker's label and fill the coolant tank through the chip tray area.
9. Do not start cut on a sharp edge.
10. Keep machine lubricated. See "Lubrication" section.

Adjustments

Adjusting Vise Square to the Blade

1. Disconnect the machine from the power source.
2. Place a machinist's square on the table against the blade and the vise. The square should lie along the entire length of the vise and blade without a gap.
3. If adjustment is necessary, loosen bolts holding the vise and adjust vise so square lines up properly. Tighten bolts.
4. Connect machine to the power source.

Changing Blade Speeds

⚠WARNING Disconnect machine from the power source before changing blade speeds. Failure to comply may cause serious injury.

1. Disconnect machine from the power source.
2. Open pulley cover by supporting the belt cover with one hand while removing the belt cover lock knob with the other. Lower guard gently to its full open position.
3. Support motor with one hand while loosening lock handle (A, Figure 6). Lower motor gently.
4. Position belt in grooves according to the speed selection chart.
5. Tension the v-belt by pushing down on the motor and tightening the lock handle on the motor tilt plate. Correct tension is achieved when finger pressure on the belt between the two pulleys causes approximately a 1/2" deflection.
6. Close pulley cover and fasten.
7. Connect machine to the power source.

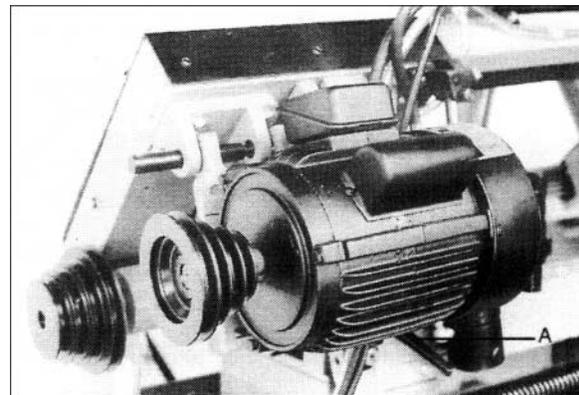

Figure 6

Adjusting Feed Rate

Rate of feed is adjusted by turning the cutting pressure control knob on the control panel. Rate of feed is important to band saw performance; excessive pressure may break the blade or stall the saw. Insufficient pressure rapidly dulls the blade.

Material chips or shavings are the best indicator of proper speed and pressure. The ideal chip is thin, tightly curled, and warm to the touch. Chips that range from golden brown to black indicate excessive force. Blue chips indicate extreme heat from too high a band speed which will shorten blade life. Thin or powdered chips indicate insufficient feed pressure.

A detailed explanation on feed rate can be found in the enclosed "Guide to Band Sawing" published by American Saw and Manufacturing Company. Reprinted by permission.

Changing Blades

⚠WARNING Disconnect machine from power source before making any adjustments or repairs. Failure to comply may result in serious injury.

1. Disconnect machine from power source.
2. Raise saw arm approximately 6 inches. Hold saw arm in place by closing cutting pressure control valve. Remove screw (#145, page 17 or 18), washer (#146), and brush (#147) from the wire brush post (#148).
3. Open both wheel covers and clean chips out of both wheel housings. Loosen two lock knobs and remove upper blade guard.
4. Release blade tension by turning blade tensioning handwheel (A, Figure 7) counter-clockwise until blade is free.
5. Loosen lock knob and slide left blade guide arm (B) to the right as far as possible.
6. Remove old blade from both wheels and out of each blade guide. **CAUTION:** Even dull blades are sharp to the skin! Use extra caution handling band saw blades!
7. Install new blade making sure teeth are pointed downward in the proper cutting direction. If necessary, turn blade inside out.
8. Position blade on band wheels and tighten just enough to hold blade on wheels. Make sure back of blade rests lightly against the wheel flange of both wheels. Twist blade slightly to allow it to slip into guides.

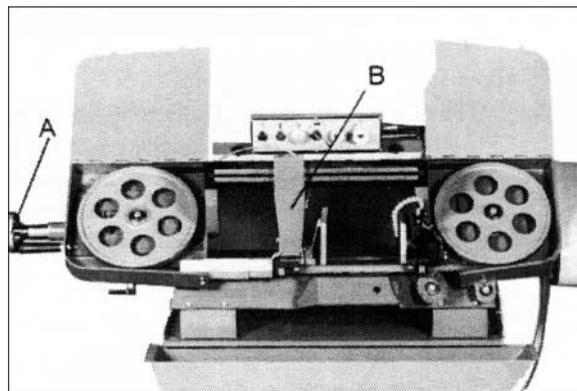

Figure 7

9. Tension blade to approximately 25,000 lbs. of blade tension, as indicated on the blade tension indicator found on the tension wheel shaft housing.
10. Attach wire brush to the wire brush post with screw and washer. Adjust wire brush post so that brush just comes into contact with blade teeth.
11. Close all covers and guards and fasten securely. Connect machine to power and run freely for approximately two minutes.
12. Turn power off and re-check blade tension and wire brush adjustment. If further adjustment is necessary, disconnect saw from power source, make adjustments, and re-connect to power.

Blade Tracking Adjustment

Blade tracking has been set at the factory and should not require adjustment. If a tracking problem occurs, adjust the machine as follows:

⚠WARNING Tracking adjustment is done with the wheel covers open to observe the blade. Use extreme caution so that you do not come into contact with the blade.

Since tracking can only be adjusted while machine is running, it is suggested that this adjustment be accomplished by qualified personnel that are familiar with this type of adjustment and the dangers associated with it.

1. Disconnect machine from power source.
2. Raise saw arm to its highest position and close cutting pressure control valve to hold saw arm in place.
3. Locate tracking adjustment plate on the back side of the driven blade wheel.
4. Loosen the three bolts (A, Figure 8) located on the top of the tracking nuts.
5. Tracking adjustment is accomplished by either loosening or tightening three adjusting nuts (B, Figure 8).
6. Tracking is set properly when the back of the blade lightly touches the wheel flange. Note: Over-tracking (allowing blade back to rub hard against wheel flange) will damage the blade wheels and blade.
7. Tighten locking bolts (A) once proper tracking is completed.
8. Connect machine to the power source.

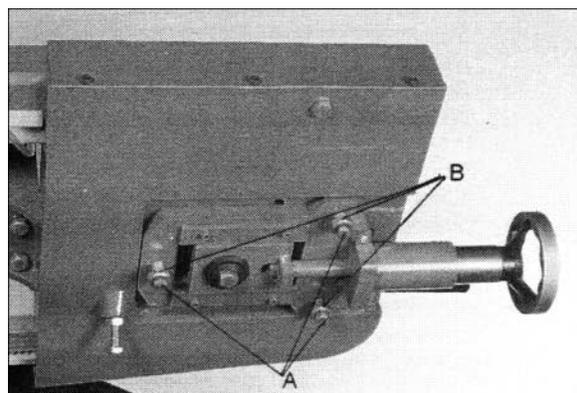

Figure 8

Automatic Shut-Off Adjustment

The motor should shut off immediately after the blade has cut through the material and just before the head comes to rest on the horizontal stop bolt. If the machine continues to run after the workpiece has been fully cut, locate and adjust the micro switch mounting plate down. If the machine shuts off before the workpiece has been completely cut, move the micro switch mounting plate up.

Thrust Roller Adjustment

1. Disconnect machine from the power source.
2. Loosen two hex socket cap screws (A, Figure 9). Note: Left guide roller has two hex socket cap screws; right guide roller has one (HBS-916W only). The HBS-1018W has two screws on each guide.
3. Move guide seat (B) up or down until a clearance of .003" to .005" between back of blade and thrust roller is obtained.
4. Tighten two hex socket cap screws (A).
5. Repeat for other blade guide assembly.
6. Connect machine to power source.

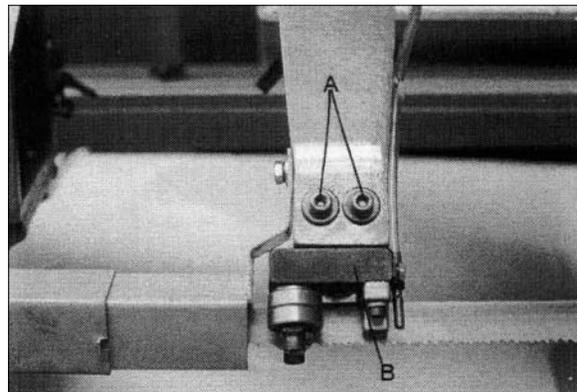

Figure 9

Guide Roller Adjustment

1. Disconnect machine from power source.
2. Loosen blade guides (A, Figure 10) by loosening screws (B). Slide blade guides away from blade.
3. Loosen locking screws (C) by using a hex wrench.
4. Adjust the eccentric bushings with a combination wrench until the ball bearings are snug to the blade. Note: Blade should travel freely up and down between the ball bearings. Do not pinch the blade.
5. Tighten locking screws (C).
6. Slide blade guides back into contact with blade and tighten screws (B).
7. Connect machine to the power source.

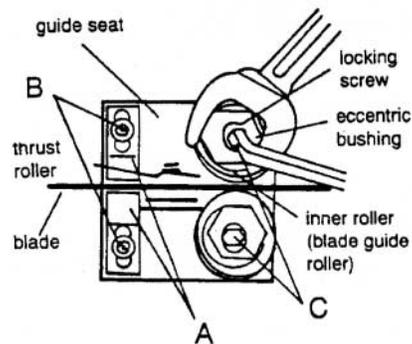

Figure 10

Bow Weight Adjustment

Bow weight is one of the most important adjustments of the saw. If the bow weight is not set properly, one can expect poor performance, crooked cuts, tooth stripping, stalling, and the blade popping off the blade wheels. The hydraulic feed rate unit will not compensate for improper bow weight. Bow weight has been set at the factory and should not need any adjustment. If adjustment becomes necessary:

1. Disconnect machine from power source.
2. Turn on hydraulic valve (F, Figure 5).
3. Turn cutting pressure control valve (E, Figure 5) counterclockwise until it stops.
4. Place one end of a fish-type scale under the blade tension handle and lift the saw with the other end. The scale should indicate approximately 18-20 lbs. for the HBS-916W. For the HBS-1018W, it should indicate 22-24 lbs.
5. Adjust tension to approximately 18-20 lbs. (or 22-24 lbs.) by turning the adjustable C-bolt found at the end of the coil spring on the rear of the band saw.
6. Connect the machine to the power source.

Vise Adjustment

To position the moveable vise jaw:

1. Turn vise handwheel (A, Figure 11) 1/2 turn counterclockwise.
2. Move rack block (B, Figure 11) to desired location by sliding along the bed. Place the rack block onto the rack.
3. Turn the handwheel to tighten the vise.

To adjust the vise for angle cutting:

1. Loosen bolts and move vise jaw (C, Figure 11) to desired location.
2. Set the vise to desired angle, re-install nuts and tighten the nut and bolt assemblies.
3. Adjust the movable vise parallel to the fixed vise by loosening bolt (D, Figure 11), adjusting to parallel, and re-tightening bolt.

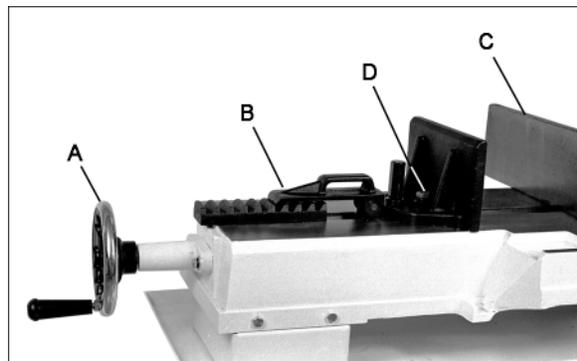

Figure 11

Maintenance

⚠WARNING Before doing maintenance on the machine, disconnect it from the electrical supply by pulling out the plug or switching off the main switch! Failure to comply may cause serious injury.

Keep the band saw and the motor clean.

If the power cord is worn, cut, or damaged in any way, have it replaced immediately.

Lubrication

All ball bearings are permanently lubricated and sealed. They require no further attention.

The gear box lubricant should be changed after the first 50 hours of operation. Change lubricant from then on every 250 hours of operation.

To check level of gear box lubricant, place saw arm in down position and allow a few minutes to pass so that oil drains down. Check level in sight glass on side of gear casing. Correct level is the dot in the middle of sight glass.

To change gear box lubricant:

1. Disconnect machine from the power source.
2. Open drain plug and allow lubricant to drain completely. Drain plug may be found on lower front of gear case under right wheel cover. Remove drain plug with a hex wrench.
3. Replace drain plug.
4. Remove filler cap (A, Figure 12) and fill gear box with Mobil DTE® Oil Heavy Medium until level reaches dot in middle of sight glass.
5. Replace filler cap.
6. Connect machine to the power source.

Use a light machine oil to lubricate all other moving parts as needed.

A detailed explanation on blade selection and blade problems and their solutions can be found in the enclosed "Guide to Band Sawing," published by American Saw and Manufacturing Company. Used by permission.

Replacement Parts

Replacement parts are listed on the following pages. To order parts or reach our service department, call 1-800-274-6848, Monday through Friday (see our website for business hours, www.waltermeier.com). Having the Model Number and Serial Number of your machine available when you call will allow us to serve you quickly and accurately.

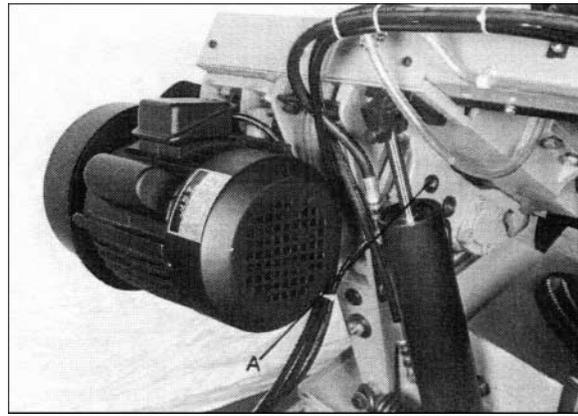
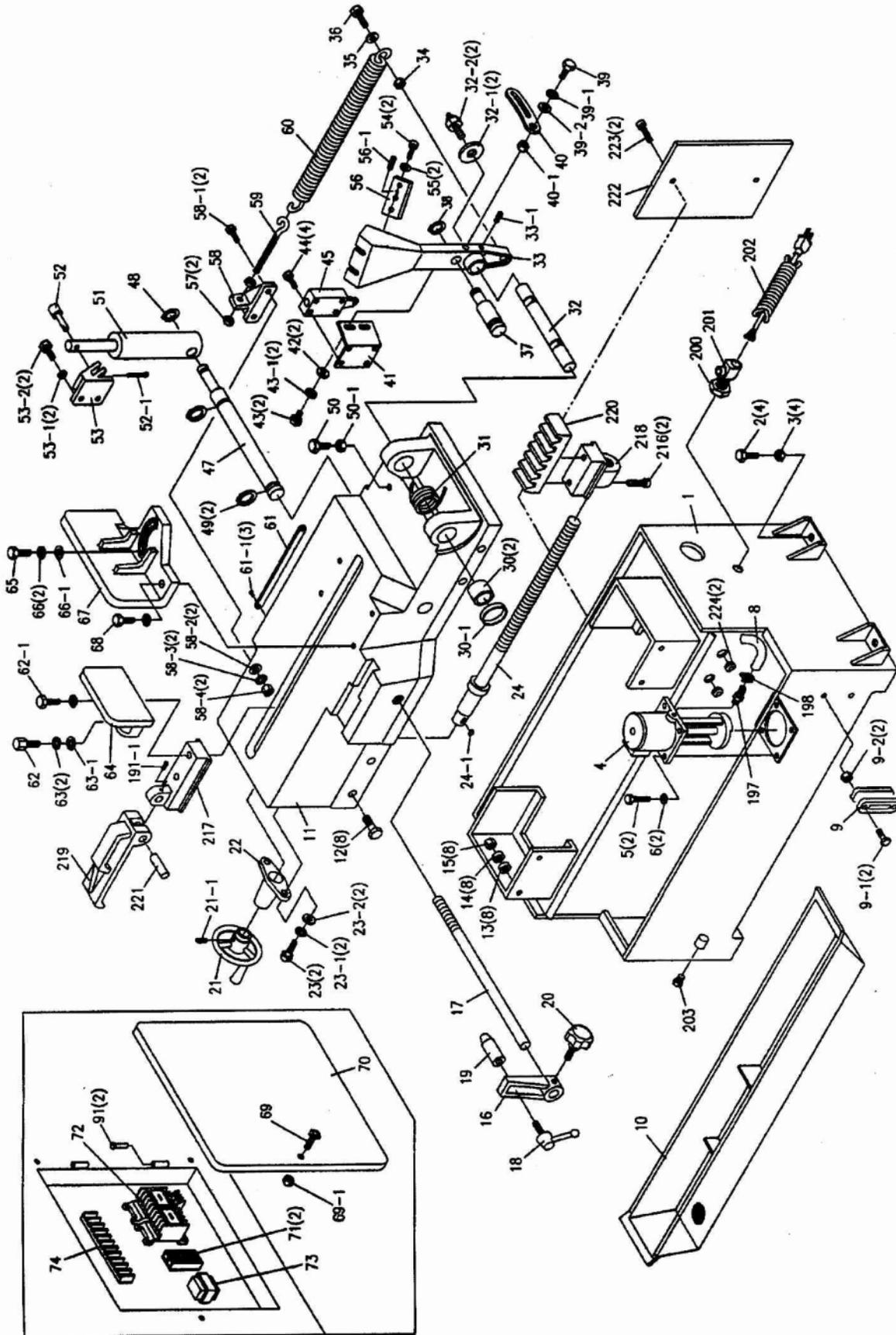
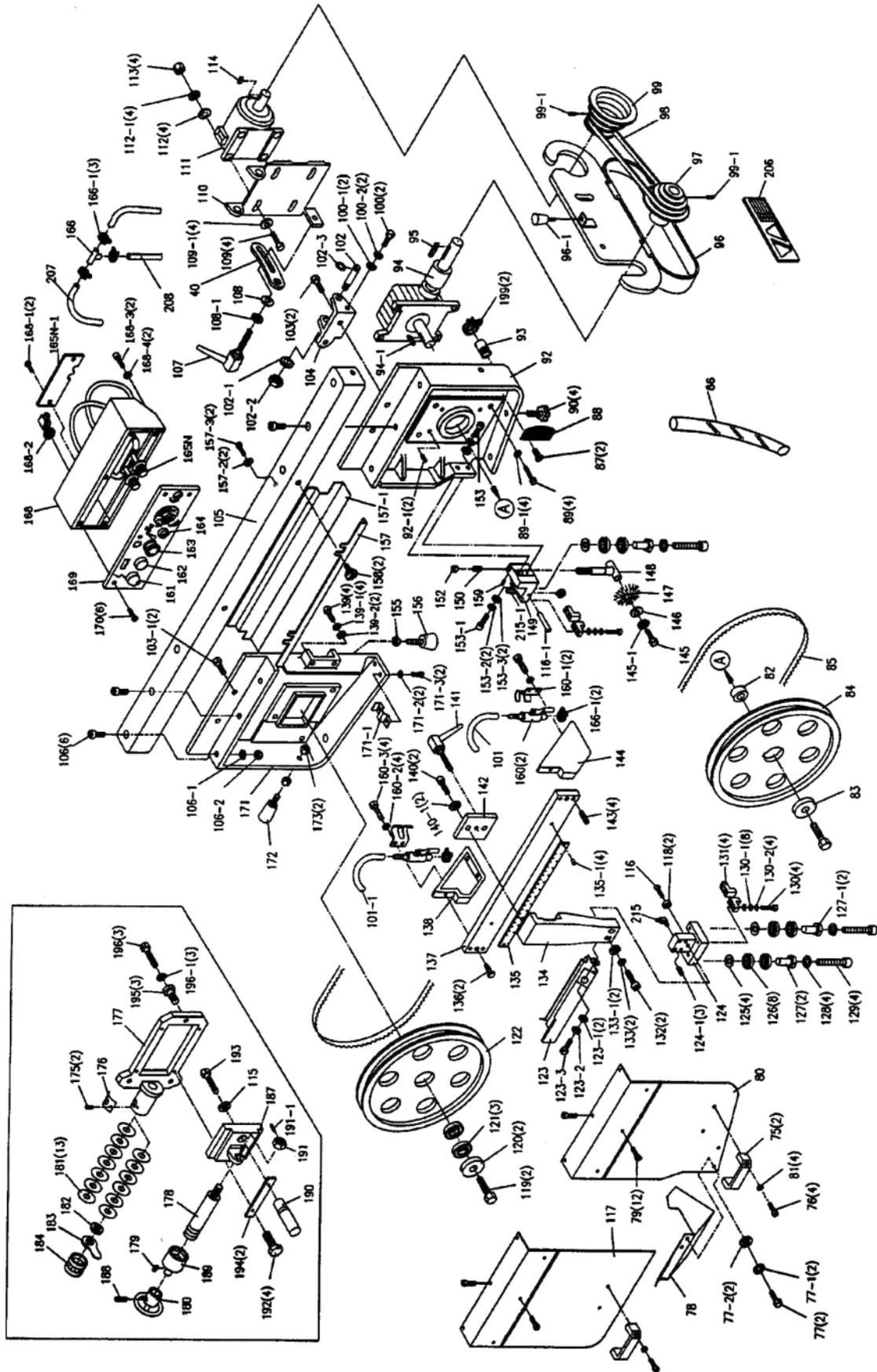

Figure 12

Base and Bed Assembly



Saw Arm Assembly – HBS-916W



Parts List for HBS-916W, HBS-1018W

Index No.	Part No.	Description	Size	Qty
1	HBS916W-01	Base (S/N 8081108 and lower)		1
	HBS916W-01A	Base (S/N 8081109 and higher)		1
	HBS1018W-01	Base (S/N 808718 and lower)		1
	HBS1018W-01A	Base (S/N 808719 and higher)		1
2	TS-1492071	Hex Cap Bolt	M12x70	4
3	TS-1540081	Hex Nut	M12	4
4	HBS916W-CP	Coolant Pump		1
5	TS-1531051	Pan Head Screw	M6x16	2
6	TS-1551061	Lock Washer	M6	2
8	HBS916W-08	Hose		1
9	HBS916W-09	Coolant Gauge		1
9-1	TS-1491041	Hex Cap Bolt	M10X30	2
9-2	TS-1540071	Hex Nut	M10	2
10	HBS916W-10	Chip Tray		1
	HBS1018W-10	Chip Tray		1
11	HBS916W-11	Bed (S/N 8081108 and lower)		1
	HBS916W-11A	Bed (S/N 8081109 and higher)		1
	HBS1018W-11	Bed (S/N 808718 and lower)		1
	HBS1018W-11A	Bed (S/N 808719 and higher)		1
12	TS-1490051	Hex Cap Bolt	M8x30	8
13	TS-1550061	Washer	8mm	8
14	TS-1551081	Lock Washer	8mm	8
15	TS-1540061	Hex Nut	M8	8
16	HBS916W-16	Stop Bracket		1
17	HBS916W-17	Stop Rod		1
18	HBS916W-18	Lock Handle		1
19	HBS916W-19	Work Stop		1
20	HBS916W-20	Lock Knob		1
21	HBS916W-21	Hand Wheel Assembly		1
	HBS1018W-21	Hand Wheel Assembly		1
21	HBS916W-21-1	Set Screw	5/16" x 8"	1
22	HBS916W-22	Lead Screw Seat		1
	HBS1018W-22	Lead Screw Seat		1
23	TS-1490051	Hex Cap Bolt	M8x30	2
23-1	TS-1551061	Lock Washer	8mm	2
23-2	TS-1550061	Washer	8mm	2
24	HBS916W-24	Lead Screw (S/N 8081108 and lower)		1
	HBS916W-24A	Lead Screw (S/N 8081109 and higher)		1
	HBS1018W-24	Lead Screw (S/N 808718 and lower)		1
	HBS1018W-24A	Lead Screw (S/N 808719 and higher)		1
24-1	HBS916W-24-1	Key	5x5x20mm	1
30	HK-2516-2RS	Needle Bearing		2
30-1	HBS916-30-1	Bushing		1
31	HBS916W-31	Torsion Spring		1
	HBS1018W-31	Torsion Spring		1
32	HBS916W-32	Pivot Shaft		1
32-1	TS-1550041	Washer	12mm	2
32-2	HBS916W-32-2	Bolt w/ Zerk Fitting		2
33	HBS916W-33	Pivot Bracket		1
	HBS1018W-33	Pivot Bracket		1
33-1	TS-1525021	Set Screw	M10x12	1
34	TS-1540081	Nut	M12	1
35	TS-1550081	Washer	12mm	1
36	TS-1492041	Hex Cap Bolt	M12x40	1
37	HBS916W-37	Torsion Spring Shaft		1
38	HBS916W-38	C-Ring	S-22	1

Index No.	Part No.	Description	Size	Qty
39	TS-1490041	Hex Cap Bolt	M8x25	1
39-1	TS-1551081	Lock Washer	8mm	1
39-2	TS-1550061	Washer	8mm	1
40	HBS916W-40	Motor Tilt Plate		1
	HBS1018W-40	Motor Tilt Plate		1
40-1	TS-1540061	Hex Nut	M8	1
41	HBS916W-41	Limit Switch Plate		1
42	TS-1550061	Washer	8mm	2
43	TS-1490031	Hex Cap Bolt	M8x20	2
43-1	TS-1551061	Lock Washer	8mm	2
44	TS-1482021	Hex Cap Screw	M6x12	4
45	HBS916W-45	Limit Switch		1
47	HBS916W-47	Cylinder Pin		1
	HBS1018W-47A	Cylinder Pin		1
48	HBS916W-48	C-Ring	S-20	1
49	HBS916W-49	C-Ring	S-25	2
50	TS-1491041	Hex Cap Bolt	M10x30	1
50-1	TS-1540071	Hex Nut	M10	1
51	HBS916W-51	Hydraulic Cylinder Assembly		1
	HBS1018W-51	Hydraulic Cylinder Assembly		1
52	HBS916W-52	Cylinder Pin		1
52-1	HBS916W-52-1	Pin		1
53	HBS916W-53	Hydraulic Mounting Plate - Top		1
	HBS1018W-53	Hydraulic Mounting Plate - Top		1
53-1	TS-1551071	Lock Washer	10mm	2
53-2	TS-1491041	Hex Cap Bolt	M10x30	2
54	TS-1492051	Hex Cap Bolt	M12x50	2
55	TS-1550081	Washer	12mm	2
56	HBS916W-56	Plate		1
56-1	HBS916W-56-1	Pin	M5x45	1
57	TS-0561051	Hex Nut	1/2"	2
58	HBS916W-58	Spring Bracket		1
58-1	TS-1490051	Hex Cap Bolt	M8x30	2
58-2	TS-1550051	Washer	8mm	2
58-3	TS-1551061	Lock Washer	8mm	2
58-4	TS-1540061	Hex Nut	M8	2
59	HBS916W-59	Adjustable C-Bolt		1
60	HBS916W-60	Spring		1
	HBS1018W-60	Spring		1
61	HBS916W-61	Angle Scale		1
61-1	HBS916W-61-1	Rivet	M2x5	3
62	TS-1492041	Hex Cap Bolt	M12x40	1
62-1	TS-1492051	Hex Cap Bolt	M12x50	1
63	TS-1551081	Lock Washer	12mm	2
63-1	HBS916W-63-1	Special Washer	12mm	1
64	HBS916W-64	Vise Jaw - left		1
65	TS-1492051	Hex Cap Bolt	M12x50	1
66	TS-1551081	Lock Washer	12mm	1
66-1	HBS916W-63-1	Special Washer	12mm	1
67	HBS916W-67	Vise Jaw - right		1
68	TS-1492041	Hex Cap Bolt	M12x40	1
68-1	TS-1551081	Lock Washer	12mm	1
69	TS-1503011	Hex Socket Cap Bolt (S/N 8081108 and lower)	M6x8	4
	HBS916W-69A	Knob (S/N 8081109 and higher)	M6x30	1
69-1	HBS916W-69-1	Nut	M6	1
70	HBS916W-70	Electrical Panel Cover (S/N 8081108 and lower HBS-916W)		1
	HBS1018W-70	Electrical Panel Cover (S/N 808718 and lower HBS-1018W)		1

Index No.	Part No.	Description	Size	Qty
	HBS916W-70A	Electrical Panel Cover (S/N 8081109 and higher HBS-916W)		1
	HBS1018W-70A	Electrical Panel Cover (S/N 808719 and higher HBS-1018W)		1
71	HBS916W-71	Fuse Block		2
	HBS916W-71A	Fuse 3A		1
72	HBS916W-72B	Magnetic Switch		1
	HBS1018W-72	Magnetic Switch		1
	HBS916W-72-1	Contactora (main motor)		1
	HBS916W-72A-1	Overload Relay		1
	HBS916W-72A-2	Contactora (pump)		1
73	HBS916W-73A	Transformer		1
	HBS1018W-73	Transformer		1
74	HBS916W-74	Terminal Strip		1
75	HBS916W-75	Handle		2
76	TS-1534051	Pan Head Screw	M6x16	4
77	TS-1482021	Hex Cap Bolt	M6x12	2
77-1	TS-1551041	Lock Washer	M6	2
77-2	TS-1550041	Washer	M6	2
78	HBS916W-78	Wire Brush Guard		1
79	TS-1503011	Hex Socket Cap Screw	M6x8	12
	HBS1018W-79A	Adjustable Bracket Mount - rear (HBS-1018W only; not shown)		1
79-1	TS-1550051	Washer (HBS-1018 only)	M6	12
80	HBS916W-80	Blade Wheel Cover - right		1
	HBS1018W-80A	Blade Wheel Cover - right		1
81	TS-1550041	Washer	M6	4
82	HBS916W-82	Bushing		1
83	HBS916W-83	Washer		1
84	HBS916W-84	Drive Wheel		1
	HBS1018W-84A	Drive Wheel	14"	1
85		Blade (local purchase, HBS-916W)		1
		Blade (local purchase, HBS-1018W)		1
86	HBS916W-86	Hose		1
87	TS-1533031	Pan Head Screw	M5x10	2
88	HBS916W-88	Filter Screen		1
89	TS-1492031	Hex Cap Bolt	M12x35	4
89-1	TS-1551081	Lock Washer	M12	4
90	HBS916W-90	Lock Knob		4
91	HBS916W-91	Hinge Pin		2
92	HBS916W-92	Blade Wheel Box - right		1
	HBS1018W-92	Blade Wheel Box - right		1
92-1	TS-1525021	Set Screw	M10x12	2
93	HBS916W-93	Connector		1
	HBS1018W-93	Connector		1
94	HBS916W-94	Gear Box Assembly (can only order entire assembly)		1
	HBS1018W-94	Gear Box Assembly (can only order entire assembly)		1
94-1	HBS916W-94-1	Key	7x7x45MM	1
95	HBS916W-95	Key	7MM	1
96	HBS916W-96	Pulley Cover		1
	HBS1018W-96	Pulley Cover		1
96-1	HBS916W-96-1	Lock Knob		1
97	HBS916W-97	Gear Box Pulley		1
	HBS1018W-97	Gear Box Pulley		1
98	VB-A39	V-Belt (for HBS-916W)		1
	VB-A37	V-Belt (for HBS-1018W)		1
99	HBS916W-99	Motor Pulley		1
	HBS1018W-99	Motor Pulley		1
99-1	TS-1524021	Set Screw	M8x10	2
100	TS-1482031	Hex Cap Bolt	M8x16	2
100-1	TS-1550061	Washer	M8	2

Index No.	Part No.	Description	Size	Qty
100-2	TS-1551061	Lock Washer	M8	2
101	HBS916W-101	Hose		1
101-1	HBS916W-101-1	Hose		1
102	HBS916W-102	Support Shaft		1
102-1	TS-1550081	Washer	M12	1
102-2	TS-1540081	Hex Nut	M12	1
102-3	HBS916W-102-3	C-Ring	S-19	1
103	TS-1492021	Hex Cap Bolt	M12x30	2
103-1	HBS916W-103-1	Hex Cap Bolt	M12x20	2
104	HBS916W-104	Motor Mount Bracket		1
105	HBS916W-105	Column		1
	HBS1018W-105	Column (S/N 606105 and lower)		1
	HBS1018W-105A	Column (S/N 606106 and higher)		1
106	TS-1506011	Hex Socket Cap Screw	M12x20	6
106-1	TS-1551081	Lock Washer	M12	1
106-2	TS-1540081	Washer	M12	1
107	HBS916W-107	Locking Handle		1
108	TS-1550061	Washer	8MM	1
108-1	TS-1551061	Lock Washer	M8	1
109	TS-1490081	Hex Cap Bolt	M8x45	4
109-1	TS-1550061	Washer	M8	4
110	HBS916W-110	Motor Mount Plate		1
111	HBS916W-111	Motor	1-1/2 HP, 1PH, 115/230V	1
	HBS1018W-111	Motor	2 HP, 1PH, 230V only	1
	HBS916W-600250	Capacitor (not shown)	400MFD, 125VAC	1
	HBS916W-111-2	Capacitor Cover (not shown)		1
	HBS1018W-111-1	Capacitor (not shown)	400MFD, 125VAC	1
	HBS1018W-111-2	Capacitor Cover (not shown)		1
112	TS-1550061	Washer	M8	4
112-1	TS-1551061	Lock Washer	M8	4
113	TS-1540061	Hex Nut	M8	4
114	HBS916W-114	Key	7MM	1
115	TS-1550081	Washer	M12	1
116	TS-1504041	Hex Socket Cap Screw	M8x20	1
116-1	HBS916W-116-1	Shaft (HBS-916W)		1
117	HBS916W-117	Blade Wheel Cover - left		1
	HBS1018W-117A	Blade Wheel Cover - left		1
118	BB-608VV	Ball Bearing		2
119	TS-1492011	Hex Cap Bolt	M12x25	2
120	TS-1550081	Washer	M12	1
121	BB-6205Z	Ball Bearing		3
122	HBS916W-122	Idler Wheel		1
	HBS1018W-122A	Idler Wheel		1
123	HBS916W-123	Blade Guard		1
	HBS1018W-123A	Blade Guard		1
123-1	TS-1550061	Washer	M8	2
123-2	TS-1551061	Lock Washer	M8	1
123-3	TS-1490021	Hex Cap Bolt	M8x16	1
124	HBS916W-124	Guide Bracket - left		1
	HBS916W-124A	Guide Bracket Assembly - left		1
	HBS1018W-124A	Guide Bracket Assembly - left		1
124-1	TS-1504031	Hex Socket Cap Screw (HBS-916W)	M8x16	3
	TS-1504031	Hex Socket Cap Screw (HBS-1018W)	M8x16	6
125	TS-1540061	Washer	M8	4
126	BB-6201VV	Ball Bearing		8
127	HBS916W-127	Eccentric Sleeve (outside)(HBS-916W)		2
	HBS1018W-127	Eccentric Sleeve (outside)(HBS-1018W)		2

Index No.	Part No.	Description	Size	Qty
127-1	HBS916W-127-1	Eccentric Sleeve (inside)(HBS-916W)		2
	HBS1018W-127-1	Eccentric Sleeve (inside)(HBS-1018W)		2
128	TS-1551061	Lock Washer	M8	4
129	TS-1504091	Hex Socket Cap Screw	M8x45	4
130	TS-1503071	Hex Socket Cap Screw	M6x30	4
130-1	TS-1550041	Washer	M6	8
130-2	TS-2361061	Lock Washer	M6	4
131	HBS916W-131	Blade Guide		4
132	TS-1504081	Hex Socket Cap Screw (HBS-916W)	M8x40	2
	TS-1504081	Hex Socket Cap Screw (HBS-1018W)	M8x40	4
133	TS-1551081	Lock Washer (HBS-916W)	M8	2
	TS-1551081	Lock Washer (HBS-1018W)	M8	4
133-1	TS-1550081	Washer (HBS-916W)	M8	2
	TS-1550081	Washer (HBS-1018W)	M8	4
134	HBS916W-134	Adjustable Bracket		1
	HBS1018W-134A	Adjustable Bracket		1
135	HBS916W-135	Scale (HBS-916W)		1
	HBS1018W-135	Dovetail Scale		1
135-1	HBS916W-135-1	Rivet (HBS-916W)	M2x5	4
	HBS1018W-135-1	Pan Head Screw (HBS-1018W)	M5x8	4
136	TS-1505031	Hex Socket Cap Screw	M10x25	2
137	HBS916W-137	Slide		1
	HBS1018W-137A	Slide		1
138	HBS916W-138	Blade Bracket - left		1
	HBS1018W-138	Blade Bracket - left		1
139	TS-1492021	Hex Cap Bolt	M12x30	4
139-1	TS-1551081	Lock Washer	M12	4
139-2	TS-1550081	Washer	M12	2
140	TS-1490041	Hex Cap Bolt (HBS-916W)	M8x25	2
140-1	TS-1551061	Lock Washer (HBS-916W)	M8	2
141	HBS916W-141	Knob		1
	HBS1018W-141	Knob		1
142	HBS916W-142	Plate		1
143	TS-1524021	Set Screw	M8x10	4
144	HBS916W-144	Blade Bracket - right		1
	HBS1018W-144	Blade Bracket - right		1
145	TS-1482011	Hex Cap Bolt	M6x10	1
145-1	TS-1551041	Lock Washer	M6	1
146	TS-1550041	Washer	M6	1
147	HBS916W-147	Wire Brush		1
	HBS1018W-147	Wire Brush		1
148	HBS916W-148	Wire Brush Rod		1
	HBS1018W-148	Wire Brush Rod		1
149	HBS916W-149	Guide Bracket - right		1
	HBS1018W-149	Guide Bracket - right		1
	HBS916W-149A	Guide Bracket Assembly - right		1
	HBS1018W-149A	Guide Bracket Assembly - right		1
150	HBS916W-150	Spring		1
	HBS1018W-150	Spring		1
152	TS-1540071	Hex Nut	M10	1
153	TS-1504091	Hex Socket Cap Screw (HBS-916W)	M8x45	2
153-1	HBS916W-153-1	Hex Socket Cap Screw (HBS-916W)	M8x55	1
153-2	TS-1551061	Lock Washer (HBS-916W)	M8	1
153-3	TS-1550051	Washer (HBS-1018W)	M8	1
154	HBS1018W-154A	Adjustable Bracket - right (HBS-1018W)		1
155	TS-1540081	Hex Nut	M12	1
156	TS-1492061	Hex Cap Bolt	M12x60	1

Index No.	Part No.	Description	Size	Qty
157	HBS916W-157	Blade Guard		1
	HBS1018W-157A	Blade Guard		1
157-1	HBS1018W-157-1	Blade Guard - down		1
157-2	TS-1482021	Hex Cap Bolt	M6x12	2
157-3	TS-1550041	Washer	M6	2
158	HBS916W-158	Lock Knob		2
159	TS-1523021	Set Screw (HBS-1018W)	M6x8	1
160	HBS916W-160	Adjusting Valve		2
160-1	HBS916W-160-1	Clamp		1
160-2	TS-1551041	Lock Washer	M6	4
160-3	TS-1482021	Hex Cap Bolt	M6x12	4
161	HBS916W-161A	Power Indicator Light		1
162	HBS916W-162	Start Switch		1
163	HBS916W-163	Stop Switch		1
164	HBS916W-164	Pump Switch		1
165N	HBS916W-165S	Feed Control - Hydraulic On/Off Valve (S/N 9111420 and lower; HBS-916W)		1
	HBS1018W-165S	Feed Control - Hydraulic On/Off Valve (S/N 911986 and lower; HBS-1018W)		1
	HBS916W-165S-K	Knob for On/Off Valve		1
	HBS916W-165S-1	Speed Control Valve (S/N 9111420 and lower; HBS-916W)		1
	HBS1018W-165S-1	Speed Control Valve (S/N 911986 and lower; HBS-1018W)		1
	HBS916W-165S-1-K	Knob for Speed Control Valve		1
	HBS916W-165N	Feed Control - Hydraulic On/Off Valve (S/N 9111421 and higher; HBS-916W)		1
	HBS1018W-165N	Feed Control - Hydraulic On/Off Valve (S/N 911987 and higher; HBS-1018W)		1
165N-1	HBS916W-165SP	Plate (S/N 9111420 and lower; HBS-916W)		1
	HBS1018W-165SP	Plate (S/N 911986 and lower; HBS-1018W)		1
	HBS916W-165N-1	Plate (S/N 9111421 and higher; HBS-916W)		1
	HBS1018W-165N-1	Plate (S/N 911987 and higher; HBS-1018W)		1
166	HBS916W-166	Connecting Tube		1
166-1	HBS916W-166-1	Hose Clamp		5
168	HBS916W-168	Control Box		1
168-1	HBS916W-168-1	Pan Head Screw	M5x10	2
168-2	HBS916W-168-2	Strain Relief		1
168-3	TS-1503031	Hex Socket Cap Screw	M6x12	2
168-4	TS-1550041	Washer	M6	2
169	HBS916W-169	Control Panel		1
170	TS-1533031	Pan Head Screw	M5x10	6
171	HBS916W-171	Wheel Box - left		1
	HBS1018W-171	Wheel Box - left		1
171-1	HBS916W-171-1	Block (HBS-916W)		1
171-2	TS-1551041	Lock Washer (HBS-916W)	M6	2
171-3	TS-1482031	Hex Cap Bolt (HBS-916W)	M6x16	2
172	HBS916W-172	Handle		1
173	TS-1540081	Hex Nut	M12	2
175	TS-1533031	Pan Head Screw	M5x10	2
176	HBS916W-176	Indicator Scale		1
177	HBS916W-177	Slide Bracket		1
178	HBS916W-178	Tension Shaft		1
179	HBS916W-179	Key	5MM	1
180	HBS916W-180	Handwheel		1
181	HBS916W-181	Lock Washer	M22	13
182	HBS916W-182	Flat Steel Washer		1
183	HBS916W-183	Tension Indicator		1
184	BB-51104	Thrust Bearing		1
187	HBS916W-187	Slide		1

Index No.	Part No.	Description	Size	Qty
188	TS-1524021	Set Screw	M8x10	1
189	HBS916W-189	Extension Bar		1
190	HBS916W-190	Wheel Shaft		1
191	HBS916W-191	Nut w/Hole For Set Screw	M14	1
191-1	TS-1523021	Set Screw	M6x8	1
192	TS-1504051	Hex Socket Cap Screw	M8x25	4
193	TS-1492011	Hex Socket Cap Screw	M12x25	1
194	HBS916W-194	Gib		2
195	HBS916W-195	Hex Cap Screw (re: HBS916W-196)		3
196	HBS916W-196	Screw Assembly		3
196-1	HBS916W-196-1	Lock Washer (re: HBS916W-196)		3
197	HBS916W-197	Hose Fitting		1
198	HBS916W-198	Hose Clamp		1
199	HBS916W-199	Hose Clamp		2
	HBS1018W-199	Hose Clamp		1
200	HBS916W-200	Nut		1
201	HBS916W-201	Strain Relief Fitting		1
202	HBS916W-202	Power Cord		1
203	HBS916W-203	Screw		1
204	HBS916W-204	Name Plate (not shown)		1
205	HBS916W-205	Warning Label (not shown)		1
	HBS1018W-205	Warning Label (not shown)		1
206	HBS916W-206	Speed Chart Label		1
207	HBS916W-207	Hose		1
208	HBS916W-208	Hose		1
213	TS-1550071	Washer	M10	2
214	HBS1018W-214	Clamp		2
215	HBS916W-215	Cu Connector		1
	HBS1018W-215	Cu Connector		2
215-1	HBS916W-215-1	Cu Connector (HBS-916W)		1
216	TS-1504051	Hex Socket Cap Screw	M8x25	2
217	HBS916W-217	Slide Bracket		1
218	HBS916W-218	Lead Screw Bracket		1
219	HBS916W-219	Rack Block		1
	HBS1018W-219	Rack Block		1
220	HBS916W-220	Rack		1
	HBS1018W-220	Rack		1
221	HBS916W-221	Pin		1
222	HBS916W-222	Plate		1
	HBS1018W-222	Plate		1
223	TS-1503011	Hex Socket Cap Screw	M6x8	2
224	HBS916W-224	Rubber Ring		2

Gear Speed Reducing Box Assembly

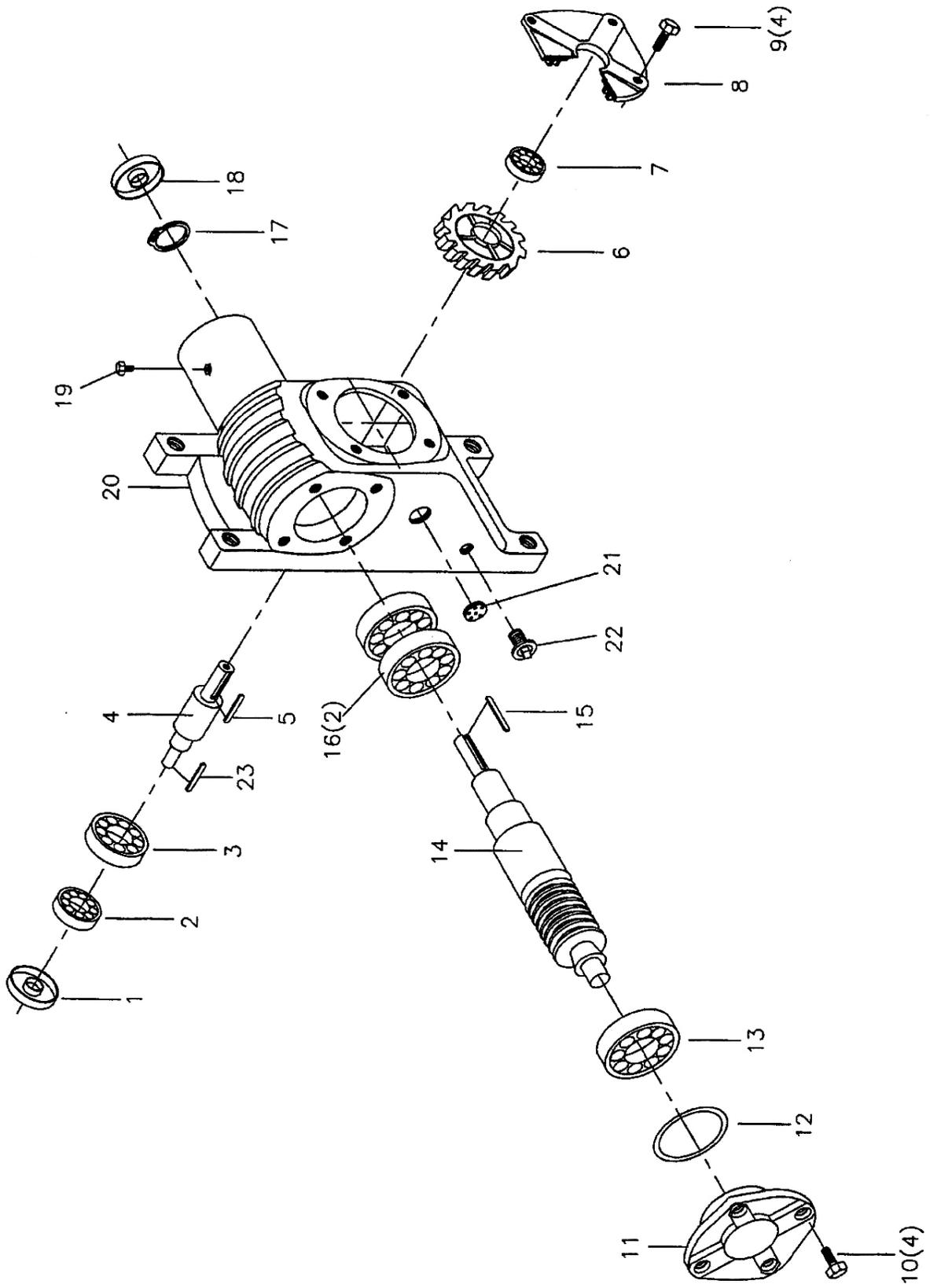

Parts List for Gear Speed Reducing Box Assembly

Index No.	Part No.	Description	Size	Qty
1	HBS916W-94-01	Oil Seal	35x55x8 mm	1
2	HBS916W-94-02	Bearing	30207	1
3	HBS916W-94-03	Bearing	6207	1
4	HBS916W-94-04	Shaft		1
5	HBS916W-94-05	Key	8x7x30 mm	1
6	HBS916W-94-06	Gear Wheel		1
7	HBS916W-94-07	Bearing	6206	1
8	HBS916W-94-08	Output Shaft Cover		1
9	HBS916W-94-09	Output Hex Cap Screw	M10x20	4
10	HBS916W-94-10	Input Hex Cap Screw	M8x20	4
11	HBS916W-94-11	Input Shaft Cover		1
12	HBS916W-94-12	Washer		1
13	HBS916W-94-13	Bearing	6025	1
	HBS916W-94-13N	Bearing	30205	1
14	HBS916W-94-14	Input Shaft		1
15	HBS916W-94-15	Key	7x7x60 mm	1
16	HBS916W-94-16	Bearing	6205	2
17	HBS916W-94-17	C-Ring	R52	1
18	HBS916W-94-18	Oil Seal	25x52x8 mm	1
19	HBS916W-94-19	Vent Bolt		1
20	HBS916W-94-20	Gear Box		1
21	HBS916W-94-21	Oil Lens		1
22	HBS916W-94-22	Draw Plug		1
23	HBS916W-94-23	Key	7x7x45 mm	1

Electrical Connections – HBS-916W

1PH Electrical Schematics for the HBS-916W

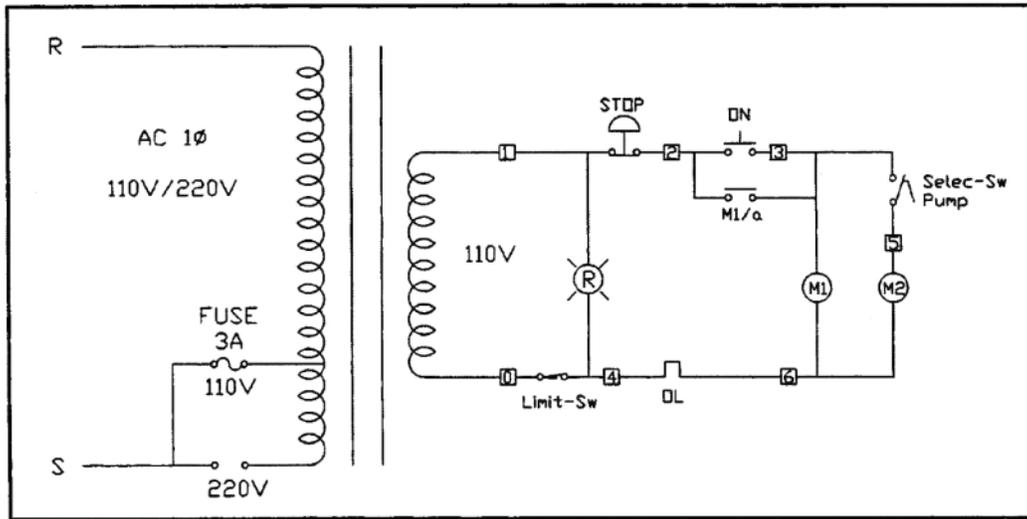

Electrical Panel Layout

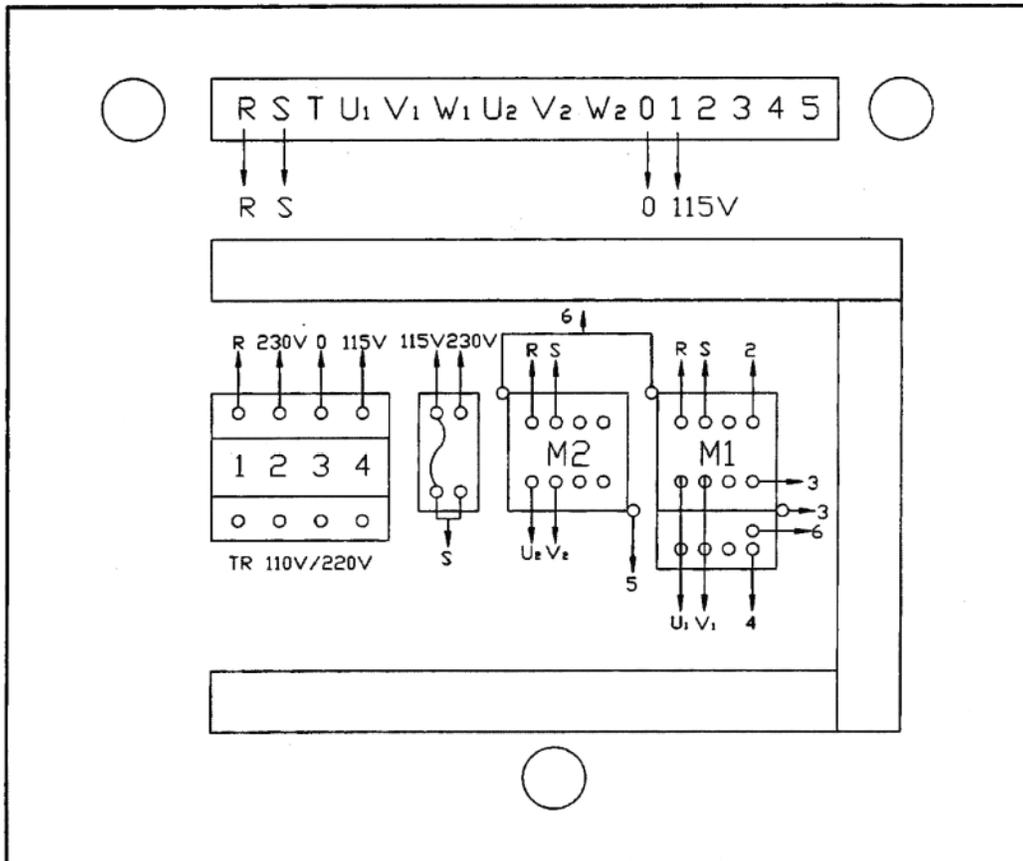

Electrical Connections – HBS-1018W

1PH

Electrical Schematic for the HBS-1018W

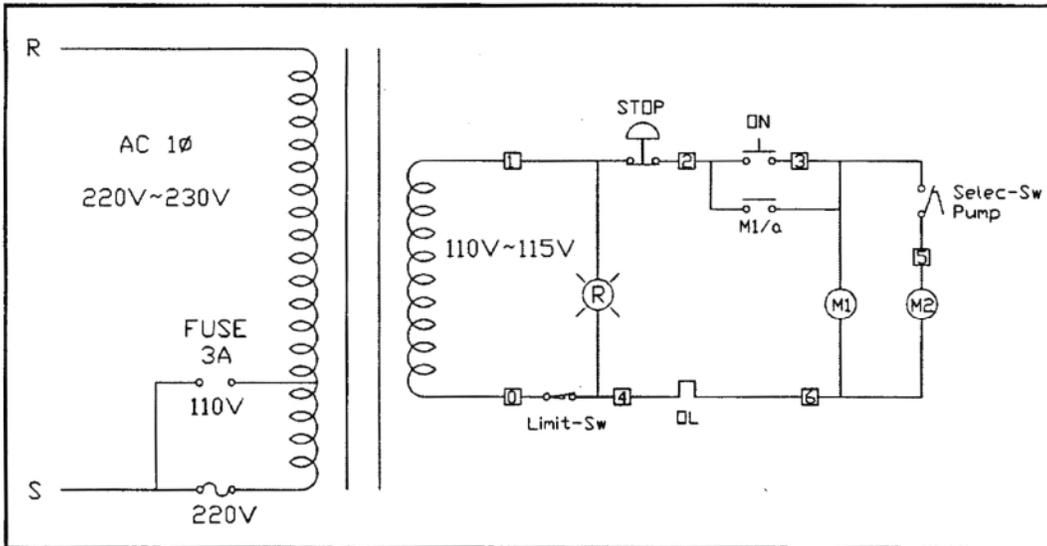

Electrical Panel Layout

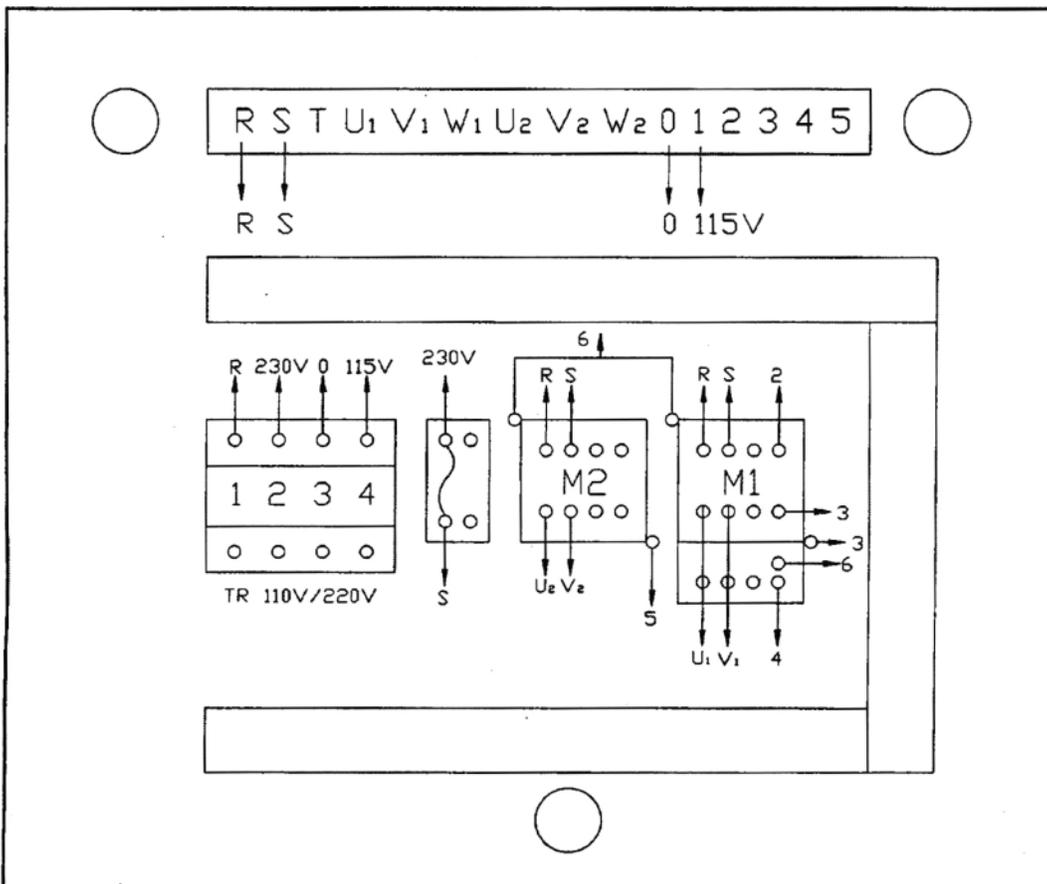

NOTES



WALTER MEIER (Manufacturing) Inc.

427 New Sanford Road
LaVergne, Tennessee 37086
Phone: 800-274-6848
www.waltermeier.com