

# NATIONAL

SHEET METAL MACHINES, INC.

SAFETY & INSTRUCTION  
MANUAL

FOR MODEL

N12016 BRAKE

MADE IN USA



**Trick-Tools.com**

80 Truman Road

Pella, IA 50219

Phone: 1-877-VAN-SANT

E-mail: sales@trick-tools.com



# CONTENTS

For Safe and Efficient Operation .....	1
Safe Zone.....	2
Parts Lists. ....	3-4
Machine Dimensions .....	5
Floor Bolt Patterns .....	5
Anchor Points .....	5
Set-Up Procedures.....	6
Adjusting Procedure .....	7
Beam Adjustment. ....	7
Adjusting Nose bar for Straightness.....	7
After Nose Bar is Straight.....	8
Rated Bending Capacity .....	9
Preventative Maintenance.....	10
Recommended Lubricant.....	10
Troubleshooting Guide.....	10
Warranty.....	11

**RECORD MACHINE INFORMATION HERE**  
( Necessary for Factory Service, Replacement Parts, etc. )

Model Number :

---

Serial Number :

---

Date Installed :

---

Purchased Through :

---

# NATIONAL

## SHEET METAL MACHINES, INC.

### SAFETY

NEVER place any part of your body under the Blade Area...

NEVER stack material to be bent. Design is for one (1) piece at a time...

NEVER place material in the brake that is over capacity or not designed to bend...

Check for broken or damaged parts before using you brake.. Repair or replace damaged parts....

ALWAYS keep children, pets, and visitors at a SAFE distance from this machine  
When operating...

Keep floors dry and free of clutter and slippery materials, maintain good footing and blance, and do NOT "OVERREACH"...

ALWAYS check the Zone Working Area (see Safe Zone Diagram pg. 3) before you start your bend. Be sure the area is clear of ALL people.

Use Common sense when using this brake. THINK SAFETY at ALL times.  
DO NOT use the brake if you are fatigued...

ALWAYS use replacement parts that are manufactured for this brake...

ALWAYS check your Counterweight Rods and Counterweights to make sure they are SECURE BEFORE you use the brake...

Floor brakes should be bolted to the floor, bench brakes should be bolted to stand, then stand and brake should be bolted to floor to prevent brake from tipping over when bending force is applied....

Follow Preventative Maintenance Guide Daily...

Anyone who operates this brake should read the COMPLETE brake manual BEFORE they use the brake.....

NEVER bend rods, wires, multiple thicknesses, or across lock seams. Operations Of this type will result in denting the edge of the Apron and Beam and springing the machine out of line.

**SAFETY SAVES AND SAFETY PAYS**

# SAFE ZONE (Working Area)

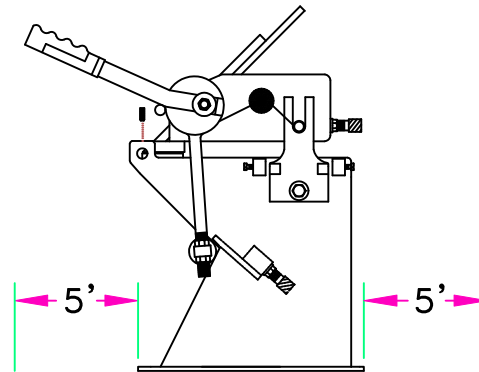
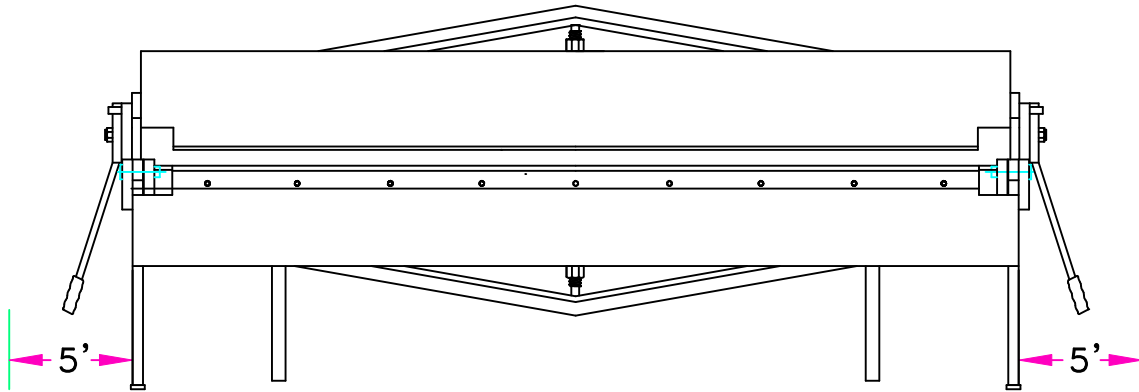

1. Allow a minimum five (5) feet of open area, free of materials, and machinery on BOTH sides (Left & Right) of machine.
2. Allow a minimum ten (5) feet of open area, free of obstruction, etc. in REAR of machine.
3. Allow a minimum ten (5) feet of open area, free of obstruction, etc. except OPERATOR in FRONT of machine.
4. Do NOT operate machine when People or Obstructions are within SAFE ZONE. Serious injury may occur.
5. Do NOT stack, store or place material, machinery, or any other obstructions in FRONT of machine that might cause tipping or in any way present a HAZARD to operators and/or helpers.

KEEP WORK AREA AND SAFE ZONES CLEAN

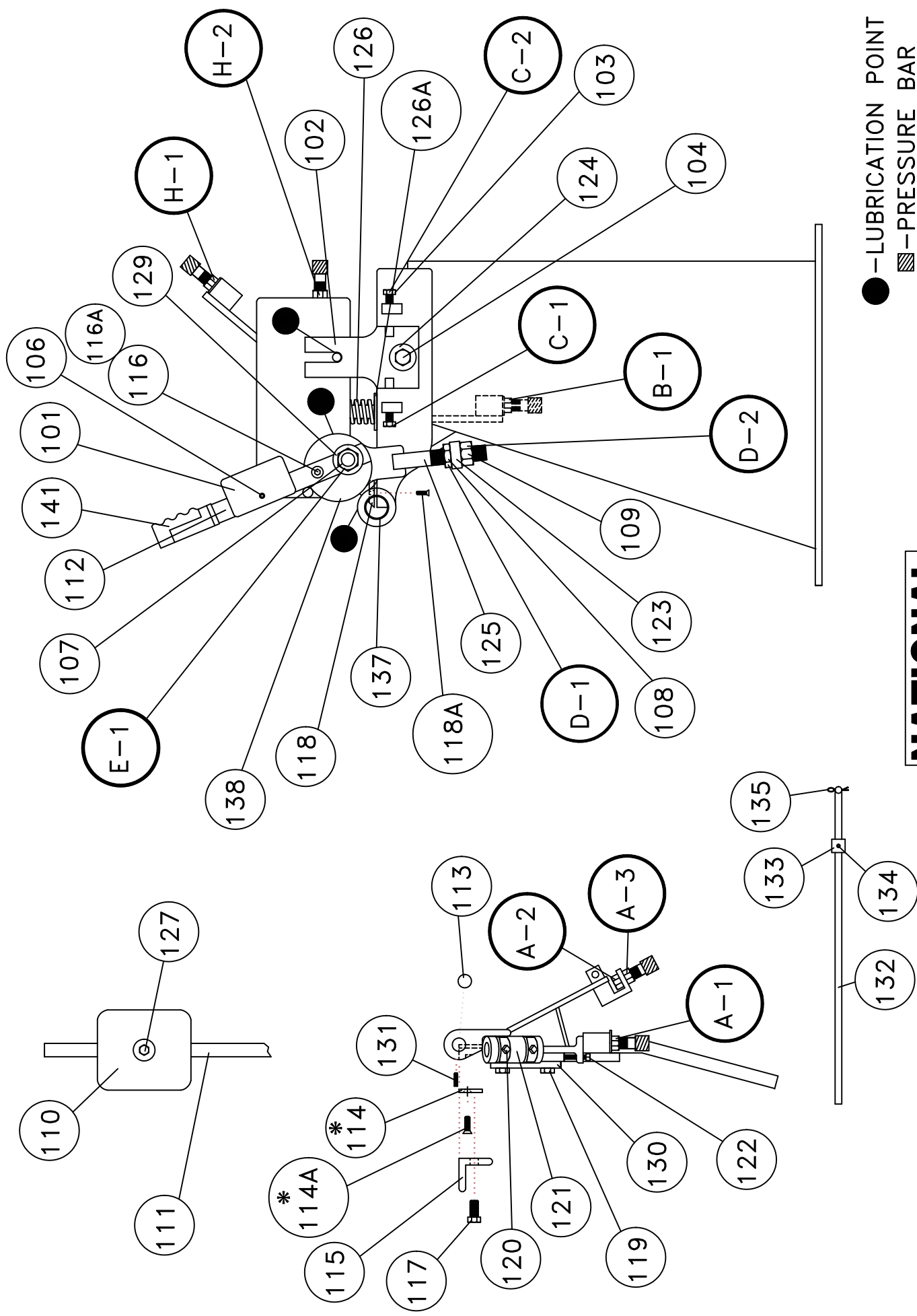

- - LUBRICATION POINT
- ▨ - PRESSURE BAR
- \* - OPTIONAL PART

**NATIONAL**

PARTS LIST N4812, N7212, N9614, N12016, N12014, N14418  
 HAND BRAKES

# NATIONAL

PARTS LIST N4812, N7212, N9616, N9614, N12016, N12014, N14418  
HAND BRAKES

PART#	DESCRIPTION	QTY.	PART#	DESCRIPTION	QTY.
101.	CAM HANDLE WEIGHT .....	2	121.	HINGE ASSEMBLY .....	2
102.	HEAD ADJ. SLIDE PLATE .....	2	122.	BOLT .....	2
103.	BOLT .....	4	123.	EYEBOLT .....	2
104.	BOLT .....	2	124.	WASHER .....	2
105.	NOT APPLICABLE FOR THIS MACHINE .....	-	125.	RING ASSEMBLY .....	2
106.	SPLIT PIN .....	2	126.	SAFETY SPRING .....	2
107.	NYLOC. NUT .....	2	126A.	WASHER .....	2
108.	NUT .....	2	127.	BOLT .....	2
109.	NUT .....	2	128.	NOT APPLICABLE FOR THIS MACHINE .....	-
110.	COUNTERWEIGHT .....	2	129.	WASHER .....	2
111.	COUNTERWEIGHT ROD .....	2	130.	ADJUSTING PLATE .....	2
112.	CAM HANDLE .....	2	131.	SET SCREW .....	2
113.	APRON HINGE PIN .....	2	132.	ROD-REPEAT/STOP .....	2
114.	BLADE-INSERT (OPTIONAL) .....	1	133.	COLLAR-REPEAT/STOP .....	2
114A.	SCREW-BLADE (OPTIONAL) .....	1	134.	SET SCREW .....	2
115.	BENDING ANGLE .....	1	135.	COTTER PIN .....	2
116.	BOLT .....	2	136.	DELETED .....	-
116A.	FLAT WASHER .....	2	137.	BUSHING .....	2
117.	BOLT .....	1	138.	CAM .....	2
118.	NOSE BAR .....	1	139.	NOT APPLICABLE FOR THIS MACHINE .....	-
118A.	SCREW .....	1	140.	NOT APPLICABLE FOR THIS MACHINE .....	-
119.	BOLT .....	1	141.	RUBBER GRIP .....	2
120.	SET SCREW .....	4			

# MACHINE DIMENSIONS

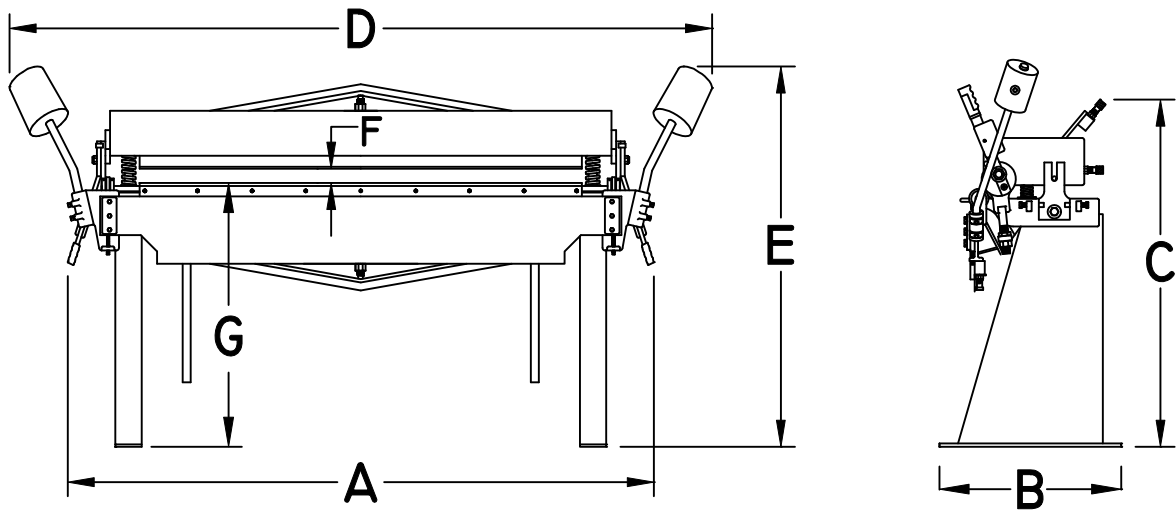

MODEL	A LENGTH	B WIDTH	C HEIGHT	D LENGTH W/C WEIGHTS	E HEIGHT W/C WEIGHTS	SHIPPING WEIGHT	F APP. MAX. CLEARANCE BETWEEN APRON EDGE & NOSE BEAM	G HEIGHT APRON EDGE
N4812	71"	27"	47-1/4"	95"	55"	1050 lbs.	1-7/8"	33"
N7212	95-1/2"	27"	48-1/4"	129"	59"	1800 lbs.	1-7/8"	33"
N9616	119-1/2"	27"	45-3/4"	143"	55"	1600 lbs.	1-7/8"	33"
N9614	119-1/2"	27"	46-1/4"	153"	59"	2500 lbs.	1-7/8"	33"
N12016	143"	27"	48-1/2"	177"	59"	2800 lbs.	1-7/8"	33"
N12014	143"	27"	48-1/4"	177"	59"	3200 lbs.	1-7/8"	33"
N14418	167"	29"	48-1/4"	201"	59"	3450 lbs.	1-7/8"	33"

## FLOOR BOLT PATTERN ANCHOR POINTS

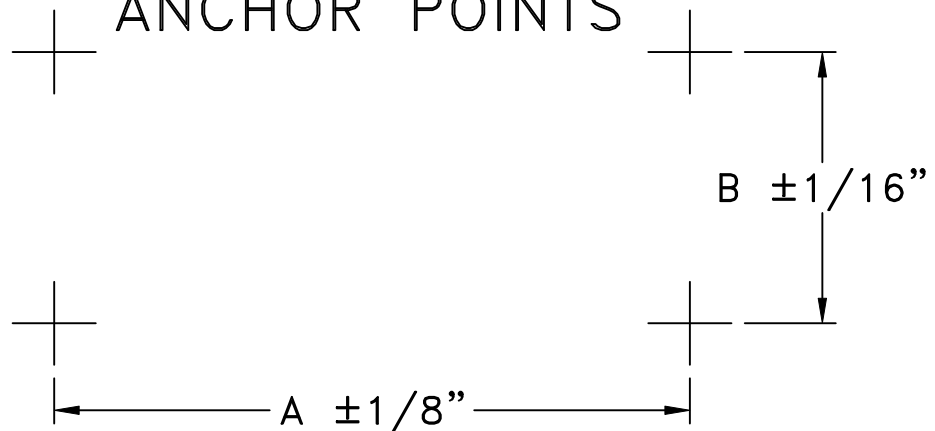

MODEL	A	B
N4812	50 3/8"	24"
N7212	74 3/8"	24"
N9616	98 3/8"	24"
N9614	98 3/8"	24"
N12016	122 3/8"	24"
N12014	122 3/8"	24"
N14418	146 3/8"	24"

N4812, N7212, N9616, N9614,  
N12016, N12014, N14418

# SET UP PROCEDURES

1. Prepare locations for machine. (See Safe Zone Diagram pg. 2, Anchor Points pg. 5, and Machine Dimensions Chart pg. 5 for proper positioning)
2. Install Anchors into floor at desired location.
3. Remove and properly dispose of all cardboard and metal wrap, inspect machine for damages.
4. Carefully position machine over Anchors.
5. Level the Brake and / or Stand and shim under the feet, if necessary, to avoid distortion.
6. Bolt Floor Brake feet **FIRMLY** to Floor to **PREVENT TIPPING**, or for Bench Brakes; bolt Brake feet **FIRMLY** to Stand and then bolt Stand and Brake to floor. Bolt the front feet of Stand **FIRMLY** to floor to **PREVENT TIPPING** when bending force is applied to the Apron Handles.

**\*\*\* If using straight edge, inspect to make sure it has maintained its Accuracy. Straightness of Nose Bar can also be checked by using a heavy gauge fishing line stretched tightly from LEFT side of machine, UNDER the Nose Bar, to RIGHT side of machine. \*\*\***



# ADJUSTING PROCEDURES

## TO ADJUST NOSE BAR FOR STRAIGHTNESS IF REQUIRED

1. Loosen Pressure Bar (H-2)
2. Tighten (H-1) until Nose Bar is STRAIGHT
3. Then tighten (H-2) back

>> **MAKE SURE NOSE BAR IS STRAIGHT BEFORE GOING ANY FURTHER**<<

The Nose Bar being the strongest member of the Brake, the material

Clamped to be bent will take same shape as Nose Bar.

Set ( C-1 ) and ( C-2 ) for material thickness per chart below.

### BEAM ADJUSTMENTS FOR MILD STEEL

Machine Gauge	Clearance
18	7 / 64"
16	1 / 8"
14	5 / 32
12	7 / 32"

\*The Upper Beam adjusts to a maximum 5/8" from Rear on Bench Brakes\*

When adjusting to bend material same as machine gauge, swing the Apron up to **90 degrees** and set the Beam Adjustment to a designated clearance between the Apron Edge and Nose Beam tip. (See Beam Adjustment Chart Above.) For lighter material, a clearance of **2 times** material thickness should be used. **SOFT Aluminum** may be formed with clearance **EQUAL** to material thickness.

# AFTER NOSE BAR STRAIGHT

1. Clamping pressure is controlled by Nuts (108) and (109) on the **LOWER END** of the Cam Bolt. This pressure should be adjusted with a small piece of the material to be bent clamped in **EACH** end of the machine. Move the Nuts (108) and (109) so that the Cam Handles (112) pull against the Stops with an **EQUAL** effort. Excessive clamping pressure is **NOT** required. Use only enough to Hold the material **FIRMLY** in the brake.
2. Use (D-1) and (D-2) to adjust clamping pressure on each end to hold material to be bent. **Excessive Pressure is NOT REQUIRED.**
3. Use (B-1) to adjust Base to clamp material in **CENTER** enough to keep material from "crawling" when Bending.
4. **BENCH BRAKES:** Make sure Apron is **FLUSH with BASE on EACH END.** Use (A-1) to move center of Apron up **1/32" HIGHER** than Base.

**FLOOR MODEL BRAKES:** Make sure Apron is **FLUSH with BASE on Each End.** Use (A-1) to move Center of Apron up **1/32" HIGHER** than Base. If Apron is Away from Base in Center use (A-2) And (A-3) to make proper adjustments. For Bow-Out loosen (A-3), tighten (A-2) until correct, Then tighten (A-3) back.

5. Set bend Clearance between Nose Bar and Apron for type of material being used. (See Beam Adjustment Chart on pg. 7.)
6. Snug NYLOC Nuts (E - 1) for proper adjustment to prevent Handles from being loose. **HEAD MAY DROP UNEXPECTEDLY IF NOT ADJUSTED PROPERLY.**

**>> MACHINE IS NOW READY TO OPERATE <<**

# RATED BENDING CAPACITY

## RATED CAPACITY FOR MILD STEEL

(With **Bending Angle (115)** REMOVED for narrow or offset bends)

Machine Gauge	Capacity
<b>18</b>	<b>20</b>
<b>16</b>	<b>18</b>
<b>14</b>	<b>16</b>
<b>12</b>	<b>14</b>

## RATED CAPACITY FOR MILD STEEL

(With **BOTH Bending Angle (115)** and **\*Optional\* Blade Insert (114)** REMOVED)

**FLOOR MODELS ONLY**

Machine Gauge	Capacity
<b>18</b>	<b>22</b>
<b>16</b>	<b>20</b>
<b>14</b>	<b>18</b>
<b>12</b>	<b>16</b>

## RATED CAPACITY FOR STAINLESS STEEL

Machine Gauge	Capacity
<b>18</b>	<b>22</b>
<b>16</b>	<b>20</b>
<b>14</b>	<b>18</b>
<b>12</b>	<b>16</b>

**\*\* ALL BRAKES ARE RATED TO BEND A 1" FLANGE \*\***

# PREVENTATIVE MAINTENANCE

1. Lubricate machine as recommended. Lubrication points are shown on Parts list List. Recommended WEEKLY lubrication to ALL lubrication points. Lasting Accuracy DEPENDS on proper lubrication.

## RECOMMENDED LUBRICANTS

Lubricate ALL moving parts of the machine with Light Grease or Heavy Oil, such as **Mobil Mobility AW-1** or **Equivalent**.

## TROUBLE - SHOOTING

1. Brake "Overbending" Material
  - A.) See Set - Up Procedures
2. Brake "Underbending" Material
  - A.) See Set - Up Procedures

# WARRANTY

National Sheet Metal Machines, Inc. warrants this product to be free of defects in material and / or workmanship for a period of **THREE (3) YEARS** from the date of purchase. National Sheet Metal Machines, Inc. promises to replace any of this product that proves upon our inspection and within **THREE (3) YEARS** from date of purchase to be defective in material or workmanship.

All labor and / or transportation cost or charges incidental to warranty service are at the expense and shall be borne by the Purchaser / User.

In **NO** event shall National Sheet Metal Machines, Inc. be liable for incidental or consequential damages, for damages as a result of neglect, misuse, abuse, or alterations of any kind to the machine.

No person is authorized to change, add to, or create any warranty of obligation other than that set forth herein.

It is the Purchaser / User's sole responsibility to obtain material that is **AT** or **BELOW** specified standards.

National Sheet Metal Machines, Inc. accepts **NO** liability or assumes any responsibility for damages, accident or injury, or any charges incurred as a result of this machine.

To obtain Warranty service, contact the dealer from which machine was purchased.

MADE IN THE USA