

Distributed by: **Trick-Tools.com**

Trick-Tools  
80 Truman Road  
Pella, IA 50219

Phone:1-877-VAN-SANT  
E-mail: [sales@trick-tools.com](mailto:sales@trick-tools.com)



Here at Trick Tools we believe that our customers deserve the best value in their tool and equipment purchases. We are constantly at work searching out a variety of high quality, high performance tools to offer at the best prices possible. Our commitment to you is that we will not offer “cheap junk” anywhere on our website. You, the customer, help us to evaluate our products constantly and as soon as an ongoing quality issue is uncovered we will correct it or discontinue that product immediately. We hope to earn your continued trust.

ITEM NO.	PART NUMBER	QTY.
1	Rigid Caster	2
2	Swivel Caster	2
3	200-150 Base Plate	1
4	HEX BOLT 5/16-18x0.75	18
5	Spring Lock Washer	18
6	Hex Nut 5/16"	18
7	HEX BOLT 1/2-13x1.125	1
8	Upright Assembly	1
9	Gusset	1

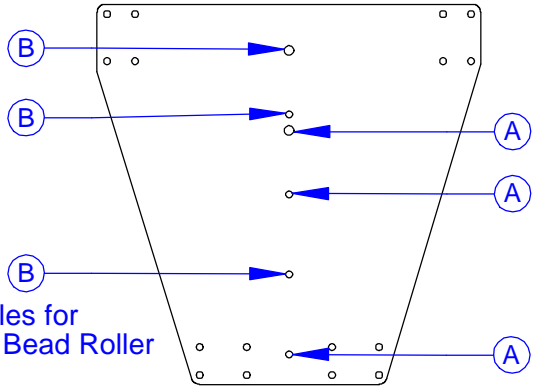

Use B Holes for  
36" & 42" Bead Roller

Use A Holes for  
24" Bead Roller  
10" & 14" Rotary Machine

Stand Fits All Bead Rollers

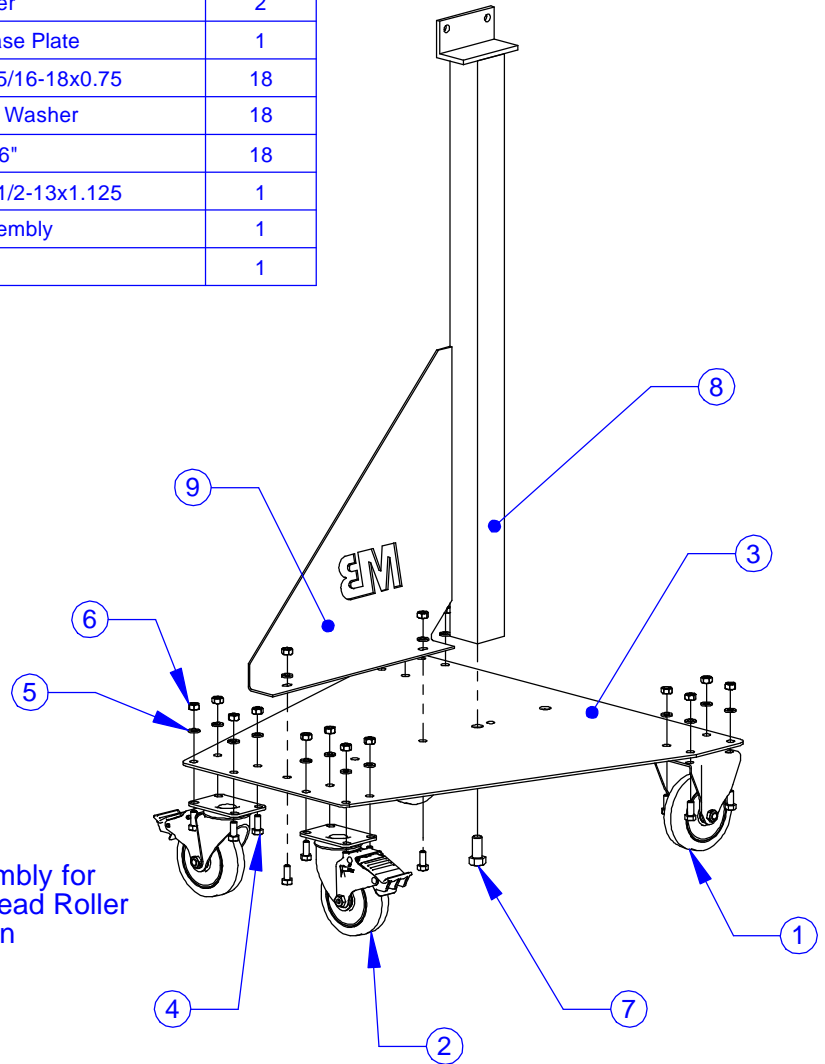
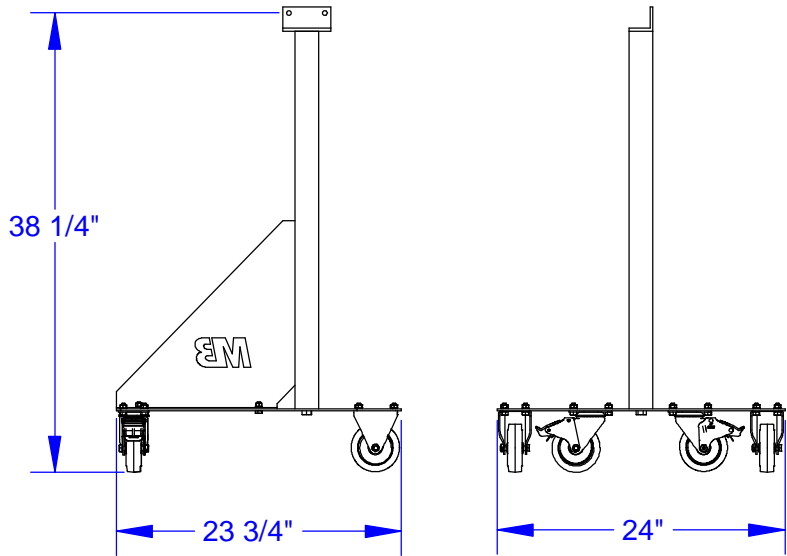

Note:  
Assembly for  
24" Bead Roller  
Shown

**PROPRIETARY AND CONFIDENTIAL**  
THE INFORMATION CONTAINED IN THIS DRAWING IS THE SOLE PROPERTY OF MITTLER BROS. MACHINE & TOOL. ANY REPRODUCTION IN PART OR AS A WHOLE WITHOUT THE WRITTEN PERMISSION OF MITTLER BROS. MACHINE & TOOL IS PROHIBITED.

		UNLESS OTHERWISE SPECIFIED:		NAME	DATE
		DIMENSIONS ARE IN INCHES		DRAWN	BAB 11/23/11
		TOLERANCES:		CHECKED	
		FRACTIONAL ±.015		ENG APPR.	
		ONE PLACE DECIMAL ±.015		MFG APPR.	
		TWO PLACE DECIMAL ±.010		Q.A.	
		THREE PLACE DECIMAL ±.005		COMMENTS	
		ANGULAR ±1°			
		QUANTITY			
		MATERIAL			
		yyyy			
		FINISH			
NEXT ASSY	USED ON				
APPLICATION		DO NOT SCALE DRAWING			

**MB MITTLER BROS. MACHINE & TOOL**  
10 Cooperative Way, Wright City, MO. 63390  
(636)745-7757 Fax (636)745-2874

TITLE:  
**Rolling Stand**

SIZE	DWG. NO.	REV
<b>A</b>	200-150	

SCALE: 1:10 WEIGHT: 33.578 SHEET 2 OF 2