



RAMS-2010 CRIMPER/BEADER

Capacity 24 Ga. Mild Steel Maximum

OPERATION:

Use the crank screw (A) to raise or lower the upper rolls (C) into and away from the item you are forming. Set depth gauge (E) by rotating the knob (F) and tightening down. Use adjusting wheel (D) to obtain fade-away or straight crimp as required. NO TOOLS NEEDED. Once item is set, turn handle (B) and push material into rolls.

*See product video for more information.

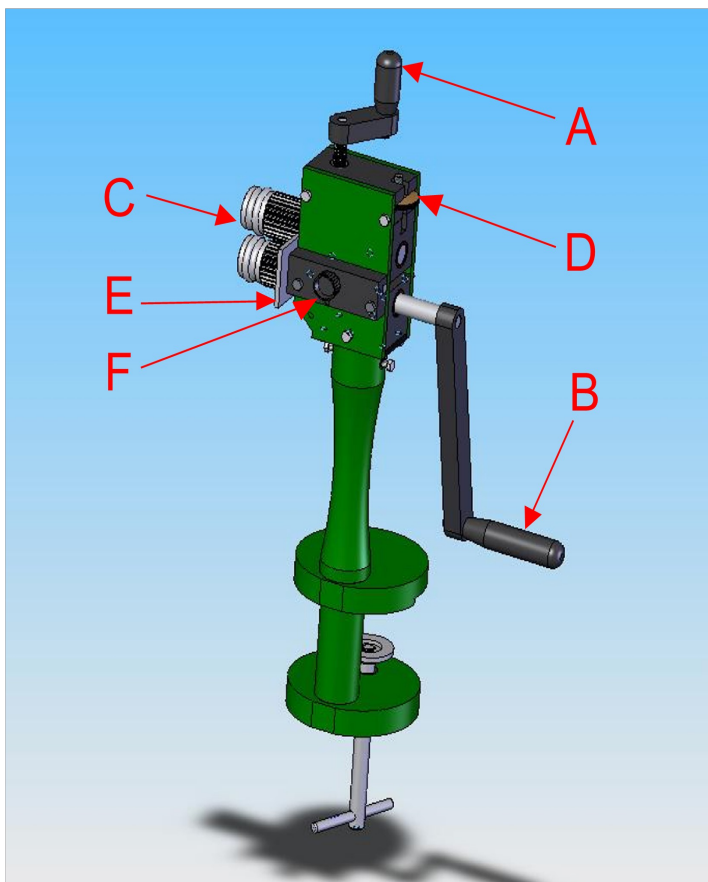

MAINTENANCE:

1. Keep rollers clean and free of galvanized deposits.
2. Occasionally spray rollers with WD-40.

AVAILABLE ROLL SETS:

RAMS 2010-K includes:

Single bead rollers
Burring Rollers
Turning Rollers
Wiring Rollers

RAMS-BD (2-3/4" extended 1/4" bead).

RAMS-OGB (2-1/2" extended OG bead).

Distributed by: **Trick-Tools.com**

Trick-Tools
80 Truman Road
Pella, IA 50219

Phone:1-877-VAN-SANT
E-mail: sales@trick-tools.com



Here at Trick Tools we believe that our customers deserve the best value in their tool and equipment purchases. We are constantly at work searching out a variety of high quality, high performance tools to offer at the best prices possible. Our commitment to you is that we will not offer “cheap junk” anywhere on our website. You, the customer, help us to evaluate our products constantly and as soon as an ongoing quality issue is uncovered we will correct it or discontinue that product immediately. We hope to earn your continued trust.