

RAMS-2019 ROTARY ROLLER CONTOURES

ROLLER SETS \$295.00

**PRM-A SPIN COLLAR
MAX 20ga**

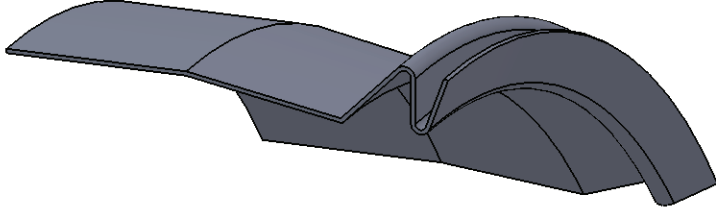

**PRM-B FLATTENING ROLL
MAX 20ga**

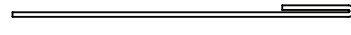
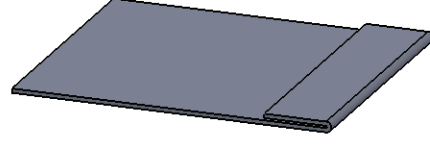

**PRM-C 45° STEP
MAX 14ga**

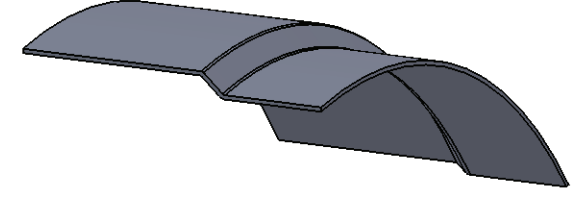

**PRM-D 3/16" STEP
MAX 14ga**

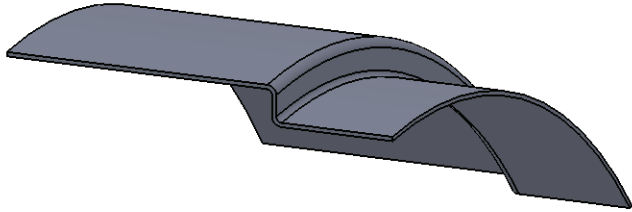

**PRM-E 1/8" STEP
MAX 14ga**

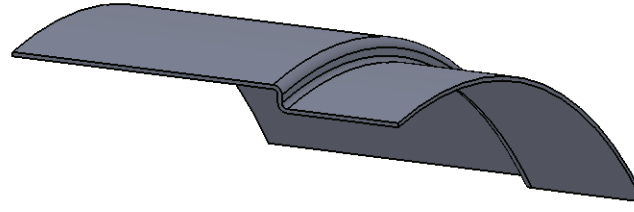

**PRM-F 1/16" STEP
MAX 14ga**

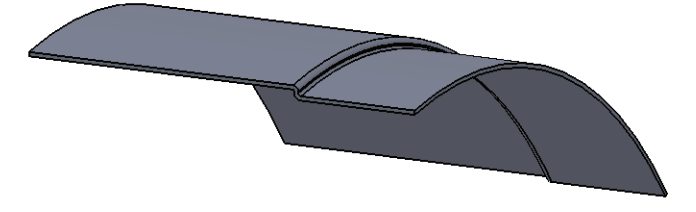

**PRM-G FINE CRIMP
MAX 20ga**

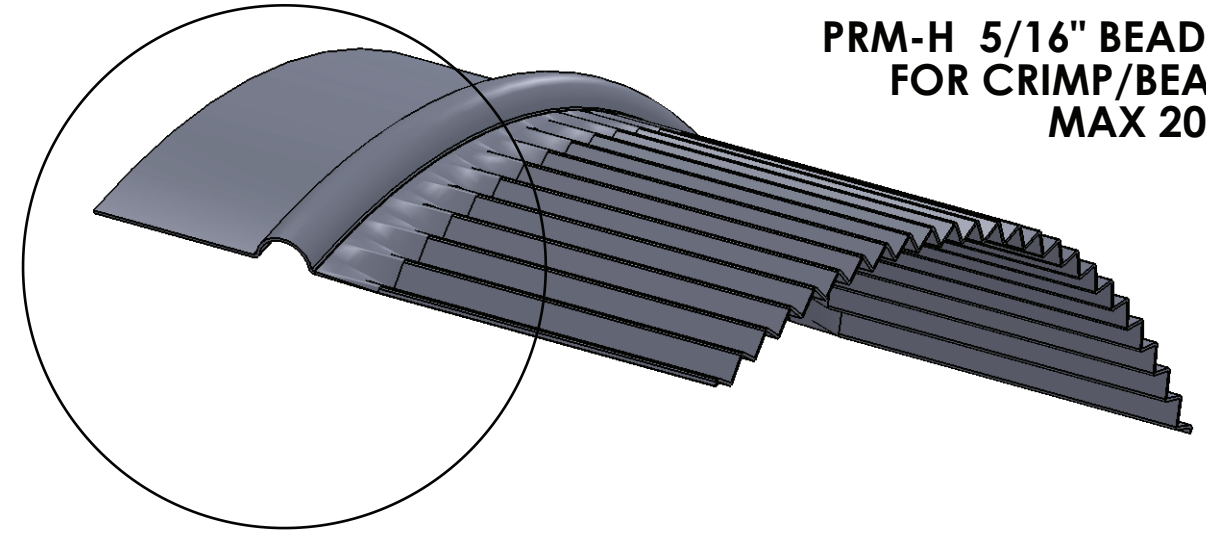
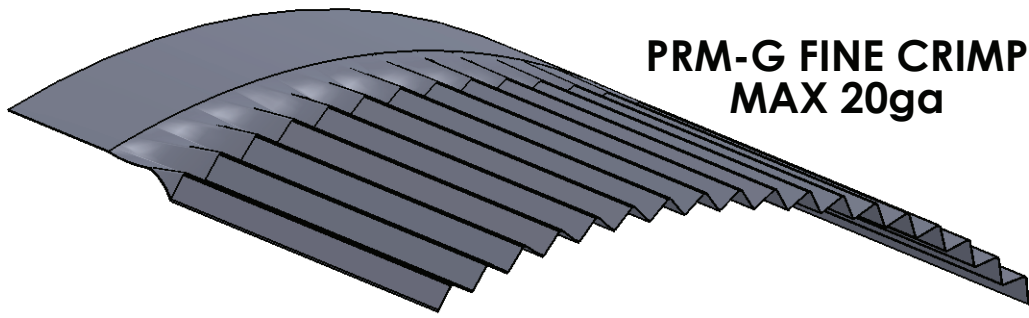

**PRM-H 5/16" BEAD ATTACHMENT
FOR CRIMP/BEAD COMBO
MAX 20ga**

**PRM-I OGEE BEADS
MAX 14ga**

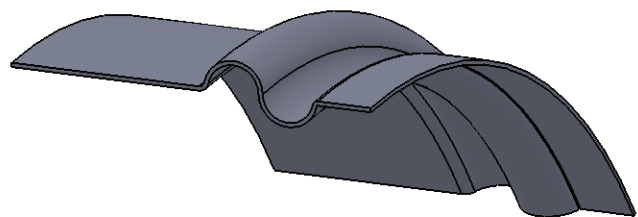

**PRM-M ELBOW EDGE
MAX 20ga**

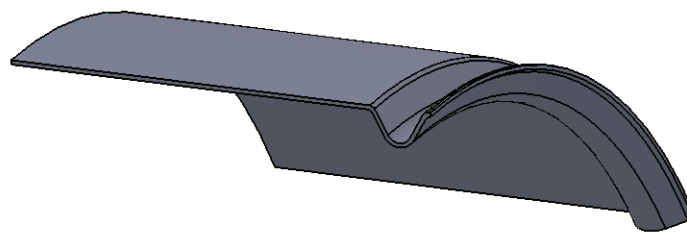

**PRM-J OFFSET SWEDGE
MAX 14ga**

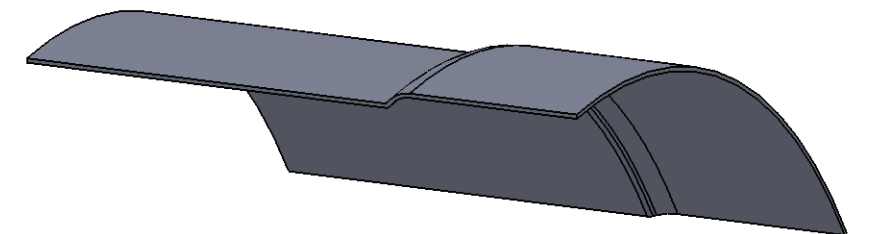

**PRM-K TURNING
MAX 20ga**

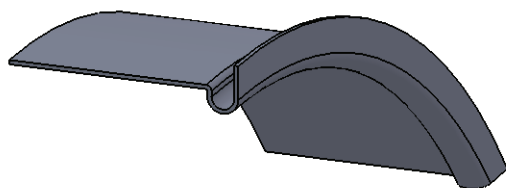

**PRM-N GORE EDGE
MAX 20ga**

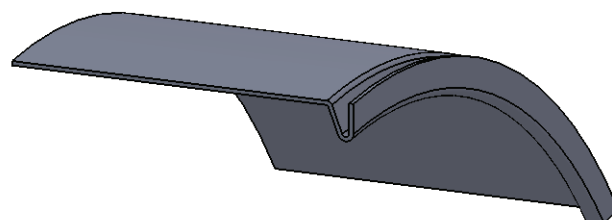

**PRM-L "V" GROOVE
MAX 14ga**

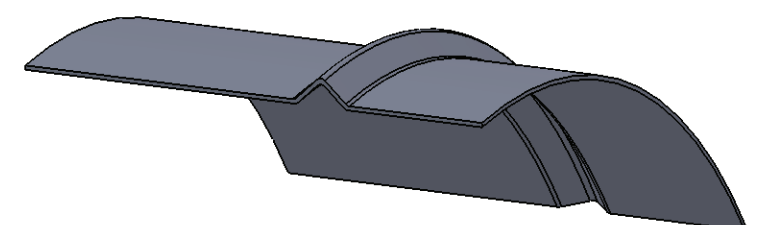

RAMS-2019 ROTARY ROLLER CONTOURES

PRM-O 1" BEAD
MAX 14ga

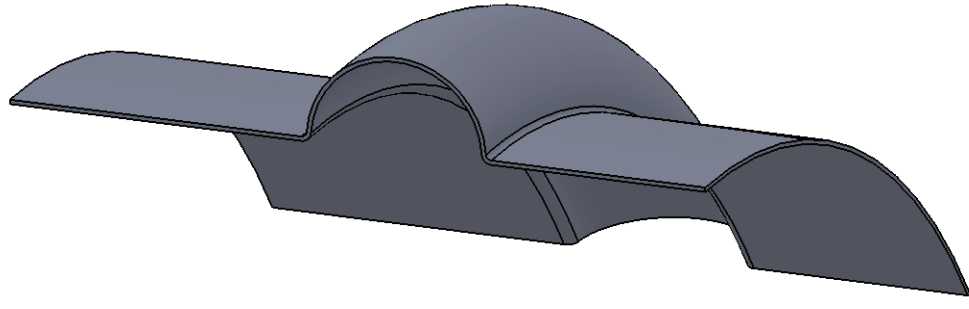

PRM-P 1/2" BEAD
MAX 14ga

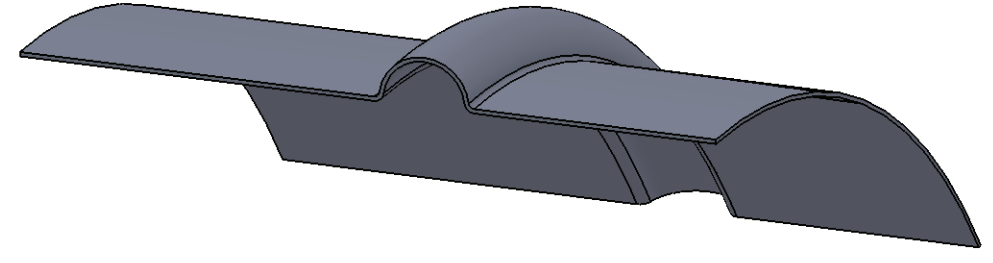

PRM-Q 3/8" BEAD
MAX 14ga

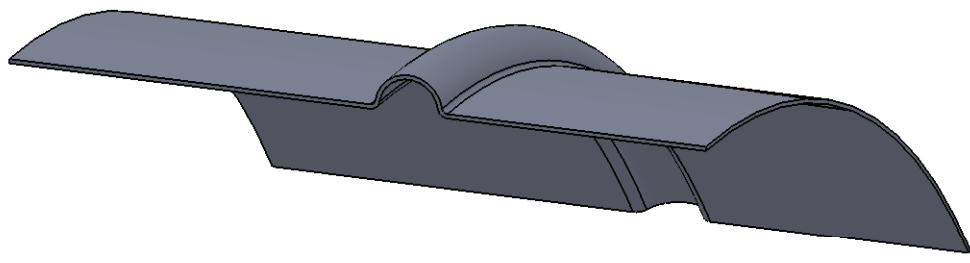

PRM-R 5/16" BEAD
MAX 14ga

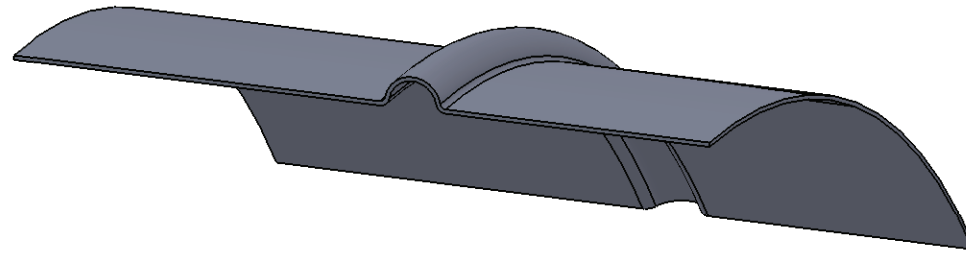

PRM-S 1/4" BEAD
MAX 14ga

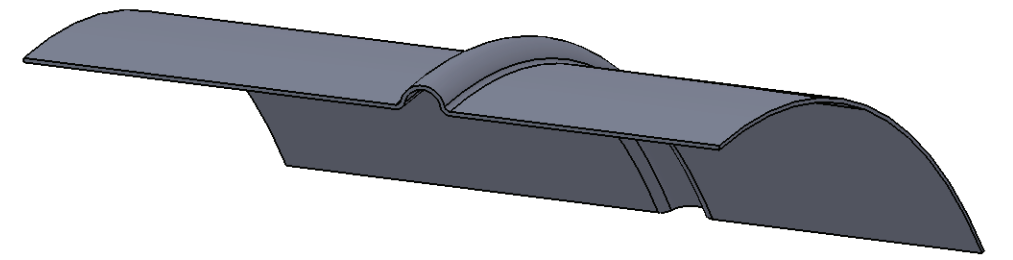

PRM-FLA 3/8" FLANGING KIT
MAX 14ga

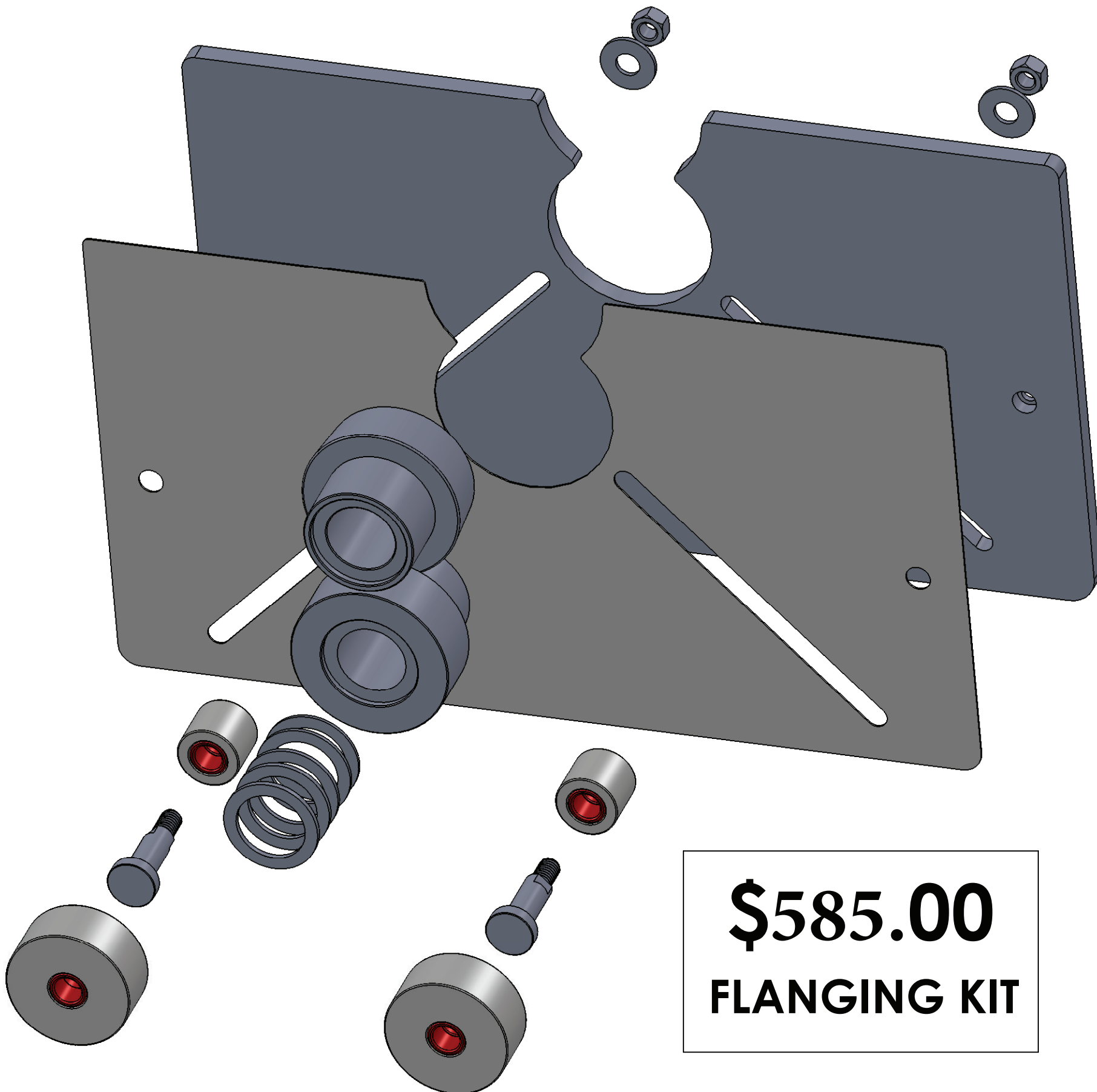
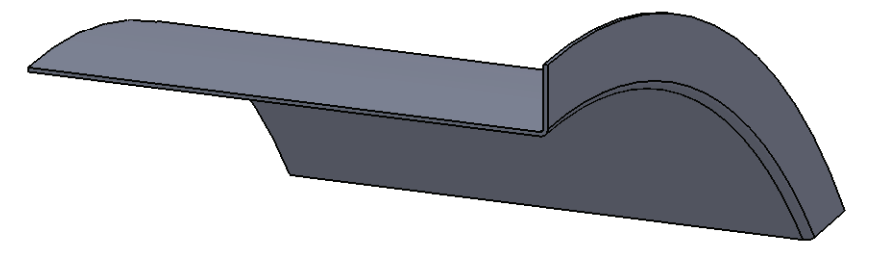

\$585.00
FLANGING KIT

ITEM NO.	PART NUMBER	DESCRIPTION	QTY.
1	RAMS-PRM-FLA-1	RAMS-PRM-U Flanging Roll Set	1
2	2019-14	PLATE	1
3	RAMS-PRM-FLA-3	2.250 OD x .688 ID x 1.00 Thick Nylon Roller	2
4	RAMS-PRM-FLA-4	1.125 OD x .688 ID x 1.00 Thick Nylon Roller	2
5	B-88	BEARING	8
6	RAMS-PRM-FLA-6	Pin	2
7	RAMS-PRM-FLA-7	0.060 Thick Spacer For 16Ga Material	1
8	RAMS-PRM-FLA-8	0.070 Thick Spacer For 18Ga Material	1
9	RAMS-PRM-FLA-9	0.080 Thick Spacer For 20Ga Material	1
10	RAMS-PRM-FLA-10	0.090 Thick Spacer For 22Ga Material	1
11	RAMS-PRM-FLA-11	0.100 Thick Spacer For 24Ga Material	1
12	RAMS-PRM-FLA-12	3/8-16 Nut (Zinc)	2
13	RAMS-PRM-FLA-13	3/8 Washer (Zinc)	2
14	2019-14-1	WEAR PLATE	1