

Distributed by: **Trick-Tools.com**

Trick-Tools
80 Truman Road
Pella, IA 50219

Phone:1-877-VAN-SANT
E-mail: sales@trick-tools.com



Here at Trick Tools we believe that our customers deserve the best value in their tool and equipment purchases. We are constantly at work searching out a variety of high quality, high performance tools to offer at the best prices possible. Our commitment to you is that we will not offer “cheap junk” anywhere on our website. You, the customer, help us to evaluate our products constantly and as soon as an ongoing quality issue is uncovered we will correct it or discontinue that product immediately. We hope to earn your continued trust.

ITEM NO.	PART NUMBER	DESCRIPTION	QTY.
1	2210-010	Frame Assembly	1
2	2210-008	Main Mounting Plate	1
3	2210-003	Rail	2
4	2210-004	Slide	1
5	2210-009	Upper Spring Holder	1
6	500-022	Cylinder Clamp	2
7	2210-005	Cover Plate	1
8	2210-501	10 Ton Cylinder	1
9	2210-006	Cylinder Stop	1
10	2210-007	Mounting Block	1
11	HX-SHCS 0.5-13x2	SHCS	3
12	HX-SHCS 0.375-16x3.75	SHCS	2
13	HX-SHCS 0.5-13x0.875	SHCS	4
14	2200-015A	Ejector Pin Assembly	1
15	500-502	Compression Spring	2
16	HJNUT 0.5000-13	Nut	1
17	HBOLT 0.5000-13x3.5	Bolt	1
18	HX-SHCS 0.375-16x4.5	SHCS	4
19	HX-SHCS 0.375-16x1.375	SHCS	2
20	HX-SHCS 0.25-20x3.75	SHCS	2

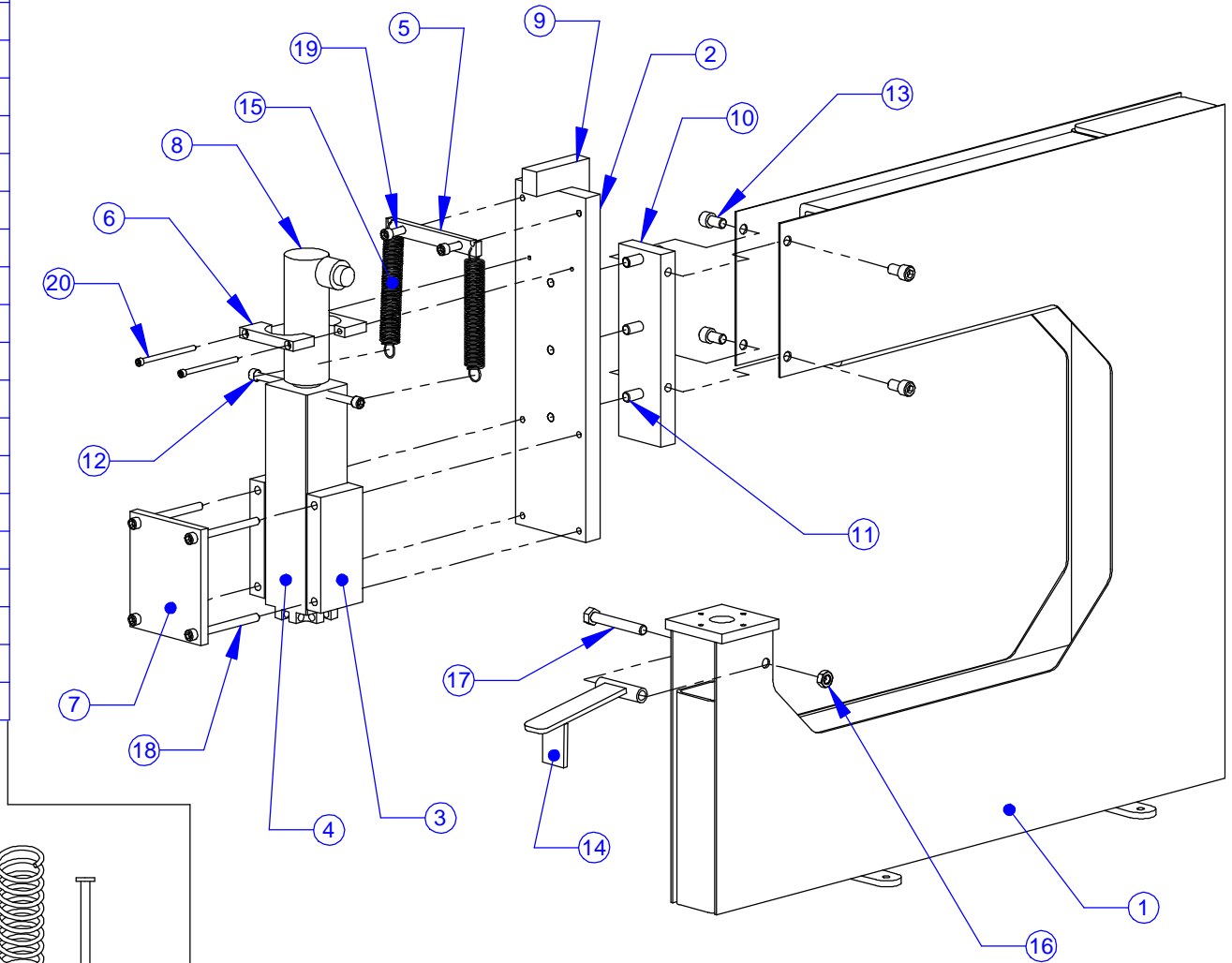

Included

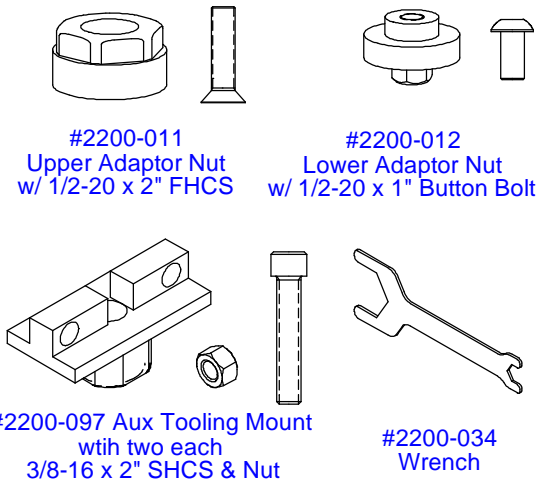

PROPRIETARY AND CONFIDENTIAL
 THE INFORMATION CONTAINED IN THIS DRAWING IS THE SOLE PROPERTY OF MITTLER BROS. MACHINE & TOOL. ANY REPRODUCTION IN PART OR AS A WHOLE WITHOUT THE WRITTEN PERMISSION OF MITTLER BROS. MACHINE & TOOL IS PROHIBITED.

5/18/11		UNLESS OTHERWISE SPECIFIED:		NAME	DATE
6/1/11		DIMENSIONS ARE IN INCHES		DRAWN	BAB 3/9/11
		TOLERANCES:		CHECKED	
		FRACTIONAL ±.015		ENG APPR.	
		ONE PLACE DECIMAL ±.015		MFG APPR.	
		TWO PLACE DECIMAL ±.010		Q.A.	
		THREE PLACE DECIMAL ±.005		COMMENTS	
		ANGULAR ±1°			
		QUANTITY			
		MATERIAL			
		YYYY			
		FINISH			
NEXT ASSY	USED ON				
APPLICATION		DO NOT SCALE DRAWING			

M3 MITTLER BROS. MACHINE & TOOL
 10 Cooperative Way, Wright City, MO. 63390
 (636)745-7757 Fax (636)745-2874

TITLE:
Hydraulic 10 Ton Press

SIZE	DWG. NO.	REV
A	2210-000	

SCALE: 1:10 WEIGHT: 310.150 SHEET 1 OF 2

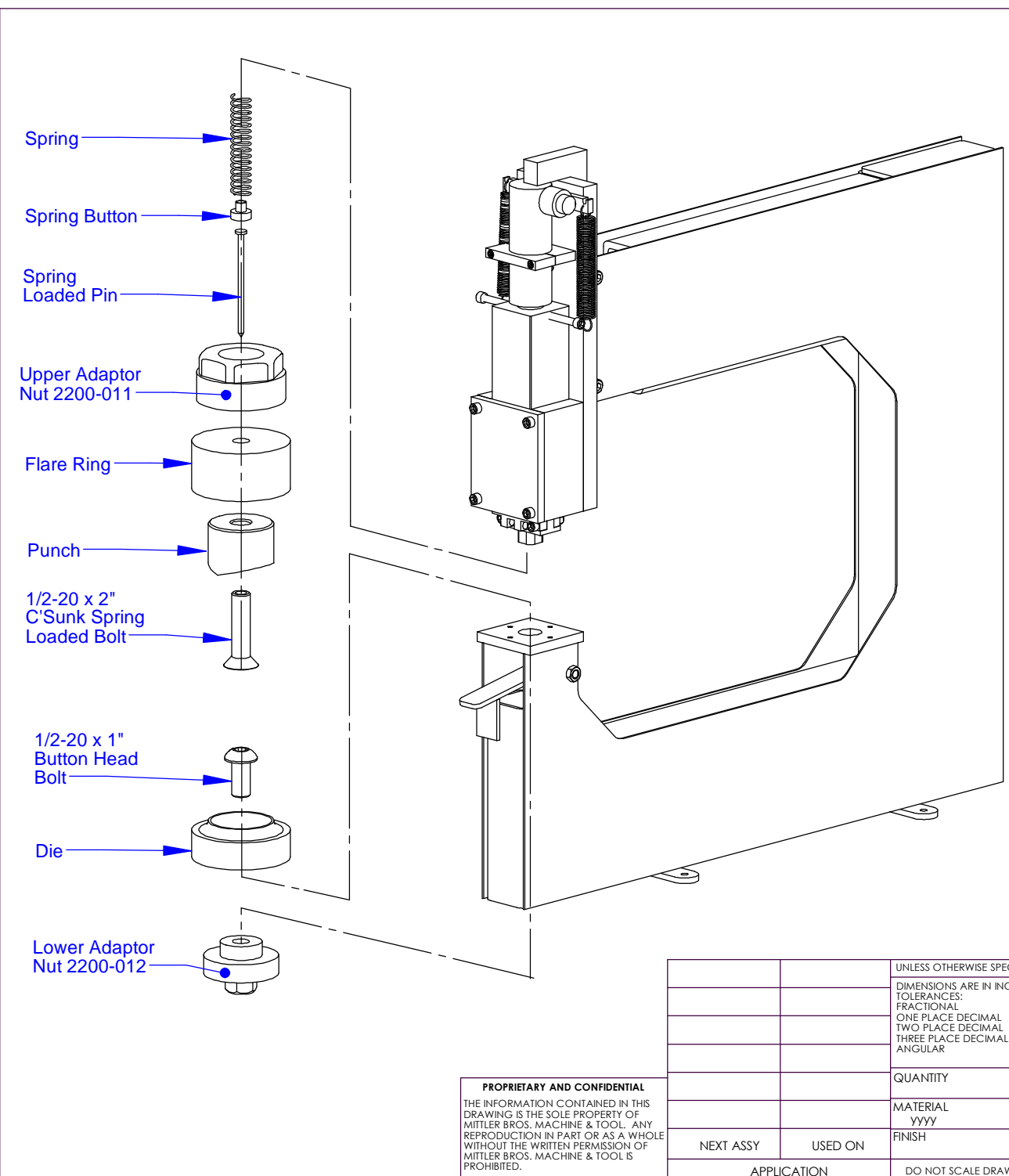

ASSEMBLY:

- Remove 1/2" - 20 Bolt and Bearing from Punch & Flare Tool - set bolt / bearing aside.
- Install Button Head Bolt through Female Die.
- Install Lower Adaptor Nut #2200-012 through hole in Lower Platen Tooling Plate
- Thread Button Head Bolt into Lower Adaptor Nut - **DO NOT Tighten.**
- Install Ejector Pin through Button Head Bolt - See Drawing
- Install 1/2"-20 Countersunk Bolt through Punch and Male Flare Ring.
- Install and Tighten 1/2"-20 Bolt into Upper Adaptor Nut #2200-011.
- Install Spring Load Pin through center of Bolt - See Drawing.
- Place a dab of grease on bottom of Spring Button to assist in Spring Button to Spring Loaded Pin Alignment.
- Place Spring Button on Bolt head.
- Install Spring over tab on Spring Button.
- Carefully Install Spring Loaded Assembly into Upper Ram Cavity while Threading Upper Adaptor Nut onto Ram.
- Tighten Upper Adaptor Nut using Wrench #2200-034.
- Lower Upper Ram / Punch / Male Flare Ring Assembly.
- Align Female Die with Punch by moving Female Die.
- Lower Assembly onto Lower Tooling Plate.
- Tighten Lower Adaptor Nut using Wrench #2200-034.

PROPRIETARY AND CONFIDENTIAL
 THE INFORMATION CONTAINED IN THIS DRAWING IS THE SOLE PROPERTY OF MITTLER BROS. MACHINE & TOOL. ANY REPRODUCTION IN PART OR AS A WHOLE WITHOUT THE WRITTEN PERMISSION OF MITTLER BROS. MACHINE & TOOL IS PROHIBITED.

		UNLESS OTHERWISE SPECIFIED:		NAME	DATE	 M3 MITTLER BROS. MACHINE & TOOL 10 Cooperative Way, Wright City, MO. 63390 (636)745-7757 Fax (636)745-2874	
		DIMENSIONS ARE IN INCHES		DRAWN	BAB		6/1/11
		TOLERANCES:		CHECKED			
		FRACTIONAL ±.015		ENG APPR.			
		ONE PLACE DECIMAL ±.015		MFG APPR.			
		TWO PLACE DECIMAL ±.010		Q.A.			
		THREE PLACE DECIMAL ±.005		COMMENTS			
		ANGULAR ±1°					
		QUANTITY				TITLE:	
		MATERIAL				Punch & Flare Assembly	
		yyyy				SIZE DWG. NO. REV	
NEXT ASSY	USED ON	FINISH				A 2210-000	
APPLICATION		DO NOT SCALE DRAWING				SCALE: 1:10 WEIGHT: 310.150 SHEET 2 OF 2	

5

4

3

2

1