



Operating Instructions and Parts Manual

Box and Pan Brakes

Models BPF-1240 and BPF-1450



BPF-1450 shown

JET
427 New Sanford Road
LaVergne, Tennessee 37086
Ph.: 800-274-6848
www.jettools.com

Part No. M-752125
Revision B1 03/2016
Copyright © 2015 JET

Distributed by: **Trick-Tools.com**

Trick-Tools
75 Truman Road
Pella, IA 50219

Phone:1-877-VAN-SANT
E-mail: sales@trick-tools.com

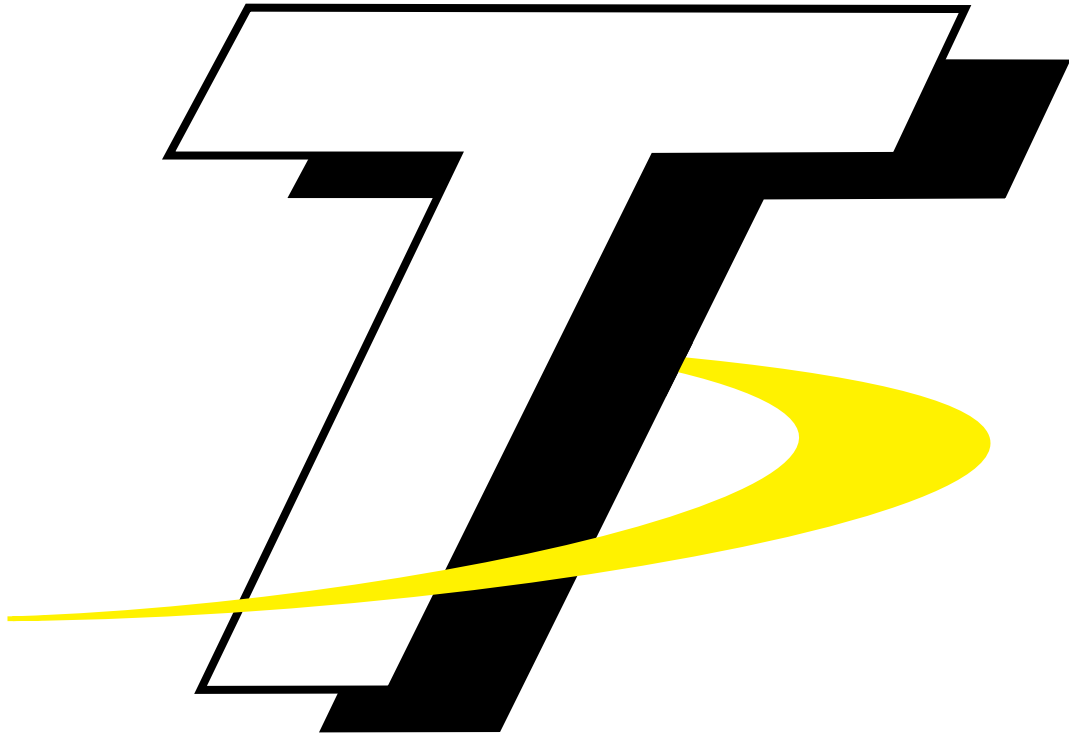

Here at Trick Tools we believe that our customers deserve the best value in their tool and equipment purchases. We are constantly at work searching out a variety of high quality, high performance tools to offer at the best prices possible. Our commitment to you is that we will not offer “cheap junk” anywhere on our website. You, the customer, help us to evaluate our products constantly and as soon as an ongoing quality issue is uncovered we will correct it or discontinue that product immediately. We hope to earn your continued trust.

1.0 Warranty and Service

JET warrants every product it sells against manufacturers' defects. If one of our tools needs service or repair, please contact Technical Service by calling 1-800-274-6846, 8AM to 5PM CST, Monday through Friday.

Warranty Period

The general warranty lasts for the time period specified in the literature included with your product or on the official JET branded website.

- JET products carry a limited warranty which varies in duration based upon the product. (See chart below)
- Accessories carry a limited warranty of one year from the date of receipt.
- Consumable items are defined as expendable parts or accessories expected to become inoperable within a reasonable amount of use and are covered by a 90 day limited warranty against manufacturer's defects.

Who is Covered

This warranty covers only the initial purchaser of the product from the date of delivery.

What is Covered

This warranty covers any defects in workmanship or materials subject to the limitations stated below. This warranty does not cover failures due directly or indirectly to misuse, abuse, negligence or accidents, normal wear-and-tear, improper repair, alterations or lack of maintenance. JET woodworking machinery is designed to be used with Wood. Use of these machines in the processing of metal, plastics, or other materials outside recommended guidelines may void the warranty. The exceptions are acrylics and other natural items that are made specifically for wood turning.

Warranty Limitations

Woodworking products with a Five Year Warranty that are used for commercial or industrial purposes default to a Two Year Warranty. Please contact Technical Service at 1-800-274-6846 for further clarification.

How to Get Technical Support

Please contact Technical Service by calling 1-800-274-6846. **Please note that you will be asked to provide proof of initial purchase when calling.** If a product requires further inspection, the Technical Service representative will explain and assist with any additional action needed. JET has Authorized Service Centers located throughout the United States. For the name of an Authorized Service Center in your area call 1-800-274-6846 or use the Service Center Locator on the JET website.

More Information

JET is constantly adding new products. For complete, up-to-date product information, check with your local distributor or visit the JET website.

How State Law Applies

This warranty gives you specific legal rights, subject to applicable state law.

Limitations on This Warranty

JET LIMITS ALL IMPLIED WARRANTIES TO THE PERIOD OF THE LIMITED WARRANTY FOR EACH PRODUCT. EXCEPT AS STATED HEREIN, ANY IMPLIED WARRANTIES OF MERCHANTABILITY AND FITNESS FOR A PARTICULAR PURPOSE ARE EXCLUDED. SOME STATES DO NOT ALLOW LIMITATIONS ON HOW LONG AN IMPLIED WARRANTY LASTS, SO THE ABOVE LIMITATION MAY NOT APPLY TO YOU.

JET SHALL IN NO EVENT BE LIABLE FOR DEATH, INJURIES TO PERSONS OR PROPERTY, OR FOR INCIDENTAL, CONTINGENT, SPECIAL, OR CONSEQUENTIAL DAMAGES ARISING FROM THE USE OF OUR PRODUCTS. SOME STATES DO NOT ALLOW THE EXCLUSION OR LIMITATION OF INCIDENTAL OR CONSEQUENTIAL DAMAGES, SO THE ABOVE LIMITATION OR EXCLUSION MAY NOT APPLY TO YOU.

JET sells through distributors only. The specifications listed in JET printed materials and on official JET website are given as general information and are not binding. JET reserves the right to effect at any time, without prior notice, those alterations to parts, fittings, and accessory equipment which they may deem necessary for any reason whatsoever. JET® branded products are not sold in Canada by JPW Industries, Inc.

Product Listing with Warranty Period

90 Days – Parts; Consumable items
1 Year – Motors; Machine Accessories
2 Year – Metalworking Machinery; Electric Hoists, Electric Hoist Accessories; Woodworking Machinery used for industrial or commercial purposes
5 Year – Woodworking Machinery
Limited Lifetime – JET Parallel clamps; VOLT Series Electric Hoists; Manual Hoists; Manual Hoist Accessories; Shop Tools; Warehouse & Dock products; Hand Tools; Air Tools

NOTE: JET is a division of JPW Industries, Inc. References in this document to JET also apply to JPW Industries, Inc., or any of its successors in interest to the JET brand.

2.0 Table of Contents

Section	Page
1.0 Warranty and Service	1
2.0 Table of Contents	3
3.0 Safety Warnings	4
4.0 About this manual	5
5.0 Features	5
6.0 Specifications	6
7.0 Set-Up and Assembly	6
7.1 Floor Diagram	6
7.2 Unpacking and cleanup	7
7.3 Assembly	7
8.0 Operation.....	7
8.1 Adjusting setback	7
8.2 Adjusting clamping pressure.....	7
8.3 Repeat bends.....	7
8.4 General procedure	8
9.0 Maintenance.....	8
10.0 Troubleshooting.....	8
11.0 Replacement Parts	8
11.1.1 Box and Pan Brake (40" model) – Exploded View	9
11.1.2 Box and Pan Brake (40" model) – Parts List.....	10
11.2.1 Box and Pan Brake (50" model) – Exploded View	11
11.2.2 Box and Pan Brake (50" model) – Parts List.....	12



3.0 Safety Warnings

1. Read and understand entire owner's manual before attempting assembly or operation.
2. Read and understand the warnings posted on the machine and in this manual. Failure to comply with all of these warnings may cause serious injury.
3. Replace warning labels if they become obscured or removed.
4. This box and pan brake is designed and intended for use by properly trained and experienced personnel only. If you are not familiar with the proper and safe operation of a brake, do not use until proper training and knowledge have been obtained.
5. Do not use this machine for other than its intended use. If used for other purposes, JET disclaims any real or implied warranty and holds itself harmless from any injury that may result from that use.
6. Do not exceed the rated capacity of the brake.
7. Always wear approved safety glasses/face shields while using this machine. Everyday eyeglasses only have impact resistant lenses; they are not safety glasses.
8. Before operating this brake, remove tie, rings, watches and other jewelry, and roll sleeves up past the elbows. Do not wear loose clothing, and confine long hair. Non-slip footwear or anti-skid floor strips are recommended.
9. Some dust created by power sanding, sawing, grinding, drilling and other construction activities contains chemicals known to cause cancer, birth defects or other reproductive harm. Some examples of these chemicals are:
 - Lead from lead based paint.
 - Crystalline silica from bricks, cement and other masonry products.
 - Arsenic and chromium from chemically treated lumber.

Your risk of exposure varies, depending on how often you do this type of work. To reduce your exposure to these chemicals, work in a well-ventilated area and work with approved safety equipment, such as face or dust masks that are specifically designed to filter out microscopic particles.

10. Do not operate this machine while tired or under the influence of drugs, alcohol or any medication.
11. Remove adjusting keys and wrenches. Form a habit of checking to see that keys and adjusting wrenches are removed from the machine before using.
12. Sheet metal stock has sharp edges. Use leather gloves when handling.
13. Keep hands and fingers clear of area in front and rear of brake.
14. This box and pan brake should be secured to the floor to prevent tipping.
15. Keep safety guards in place at all times when the machine is in use. If removed for maintenance purposes, use extreme caution and replace the guards immediately after maintenance is complete.
16. Provide for adequate space surrounding work area and non-glare, overhead lighting.
17. Keep the floor around the machine clean and free of scrap material, oil and grease.
18. Keep visitors a safe distance from the work area. **Keep children away.**
19. Give your work undivided attention. Looking around, carrying on a conversation and "horse-play" are careless acts that can result in serious injury.
20. Maintain a balanced stance at all times so that you do not fall or lean against moving parts. Do not overreach or use excessive force to perform any machine operation.
21. Use the right tool at the correct speed and feed rate. Do not force a tool or attachment to do a job for which it was not designed. The right tool will do the job better and more safely.
22. Do not stand on machine. Serious injury could occur if machine tips over.

Familiarize yourself with the following safety notices used in this manual.

CAUTION This means that if precautions are not heeded, it may result in minor injury and/or possible machine damage.

WARNING This means that if precautions are not heeded, it may result in serious or even fatal injury.

4.0 About this manual

This manual is provided by JET covering the safe operation and maintenance procedures for a JET BPF-1240 and BPF-1450 Box and Pan Brake. This manual contains instructions on installation, safety precautions, general operating procedures, maintenance instructions and parts breakdown. Your machine has been designed and constructed to provide consistent, long-term operation if used in accordance with instructions set forth in this document.

This manual is not intended to be a guide to sheet metal bending, bend allowances, material choice, etc. Consult a Machinery's Handbook and/or experienced users for such information. Whatever accepted methods or materials are used, always make personal safety a priority.

If there are questions or comments, please contact your local supplier or JET. JET can also be reached at our web site: www.jettools.com.

Retain this manual for future reference. If the machine transfers ownership, the manual should accompany it.

5.0 Features

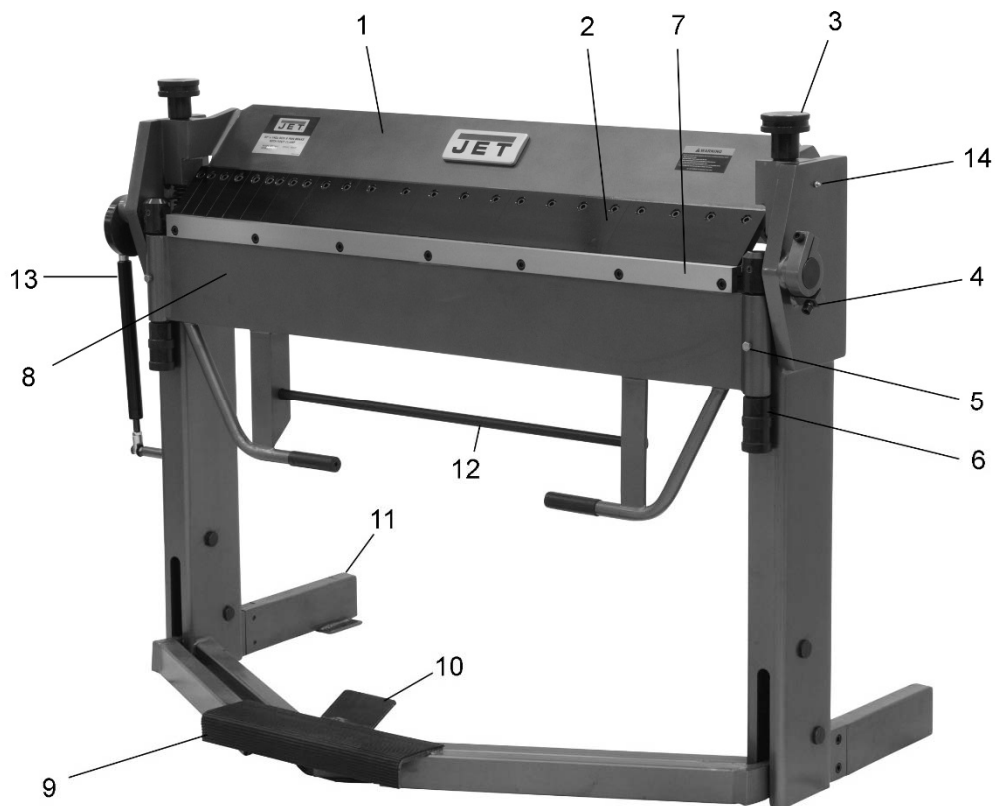

Figure 1

- | | |
|----------------------------------|----------------------------|
| 1. Clamping leaf | 8. Bending leaf |
| 2. Clamping fingers | 9. Foot pedal for clamping |
| 3. Clamping adjustment knob (x2) | 10. Foot pedal lock |
| 4. Stop bolt | 11. Support leg (x2) |
| 5. Setback locking screw (x2) | 12. Crown adjustment rod |
| 6. Setback knob (x2) | 13. Air spring |
| 7. Bending leaf blade | 14. Grease fitting (x2) |

6.0 Specifications

Model Number.....	BPF-1240	BPF-1450
Stock Number.....	752125.....	752127

Materials:

Frame.....	welded steel plate/tubing.....	welded steel plate/tubing
Clamping fingers.....	ground steel, ceramic coated.....	ground steel, ceramic coated
Clamping block/bending blade.....	precision ground steel.....	precision ground steel

Capacities:

Bending length.....	40" (1020mm).....	50" (1270mm)
Maximum thickness, mild steel.....	12 ga.....	14 ga.
Maximum beam lift.....	1-7/8" (47.6mm).....	1-7/8" (47.6mm)
Maximum box depth.....	5" (127mm).....	5" (127mm)
Finger nose angle.....	42 deg.....	42 deg.
Nose radius.....	1/32" (0.79mm).....	1/32" (0.79mm)
Number of fingers.....	11.....	12
Finger sizes.....	1", 1-1/8", 1-3/8", 1-1/2", 1-3/4", 2", 3", 4", 6", 7-3/4", 10-5/8"	1", 1-1/8", 1-3/8", 1-1/2", 1-3/4", 2", 3", 4", 6", 7-3/4", 10", 10-5/8"

Weights:

Net.....	705 lb (320 kg).....	900 lb (408 kg)
Shipping.....	780 lb (354 kg).....	988 lb (448 kg)

Dimensions:

Height, floor to working surface.....	35-1/2" (902mm).....	35-1/2" (902mm)
Shipping (LxWxH).....	58" x 25" x 50" (1473 x 635 x 1270mm).....	67" x 28" x 50" (1702 x 711 x 1270mm)
Assembled (LxWxH).....	53" x 38" x 45" (1346 x 965 x 1143mm).....	63" x 38" x 45" (1600 x 965 x 1143mm)
Footprint (LxW).....	46-1/2" x 32-1/4" (1181 x 819mm).....	56-1/2" x 35-1/4" (1435 x 895mm)

The specifications in this manual were current at time of publication, but because of our policy of continuous improvement, JET reserves the right to change specifications at any time and without prior notice, without incurring obligations.

7.0 Set-Up and Assembly

7.1 Floor Diagram

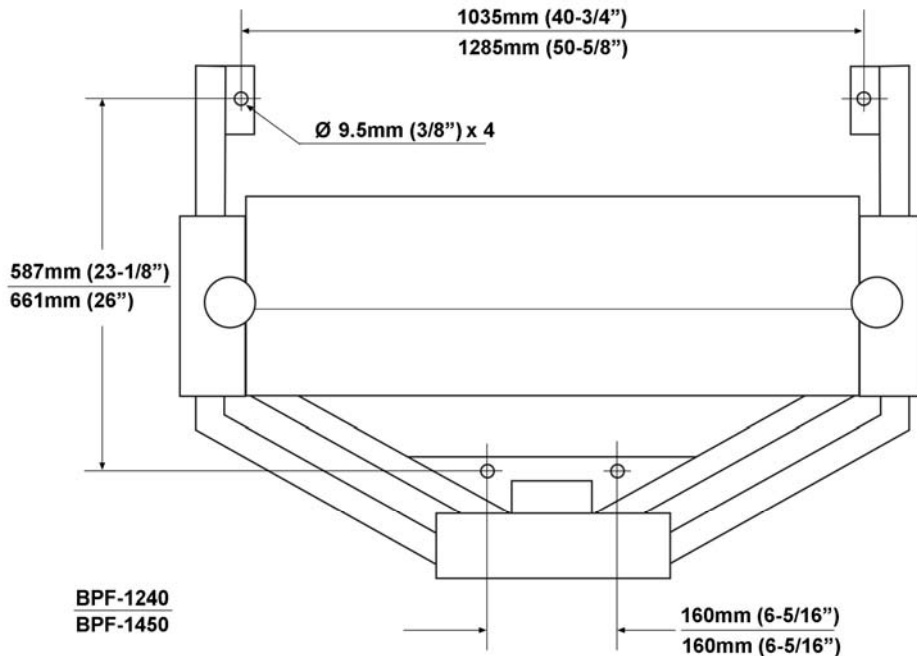

Figure 2

7.2 Unpacking and cleanup

Inspect contents of shipping container for shipping damage. Report any damage to your distributor.

Remove all contents from carton, and compare to the contents list in this manual. Report any part shortages to your distributor.

Do not discard carton or packing material until machine is assembled and working properly.

Exposed metal areas may have a rust protectant applied. Remove this with a soft rag and solvent such as kerosene. (Do not use gasoline, paint thinner, acetone, etc., as these will damage painted surfaces.)

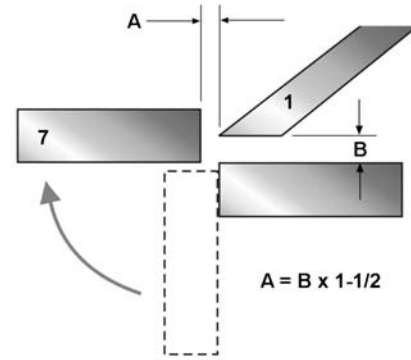

Figure 3

Contents of shipping container

- 1 Box and Pan Brake
- 2 Support legs with screws
- 1 Instructions and Parts Manual (not shown)
- 1 Warranty Card (not shown)

8mm hex key required for assembly.

7.3 Assembly

8mm hex key required for assembly.

Numbers in parentheses refer to items in Figure 1.

1. Remove any straps securing the machine, and raise into position using properly rated lifting equipment. The floor must be stable and level.

⚠WARNING Continue to stabilize the machine while installing the support legs.

2. Attach the two support legs (11) with two screws each.
3. Secure machine to floor using lag screws or similar system. See diagram, Figure 2.

8.0 Operation

Numbers in parentheses refer to items in Figure 1.

8.1 Adjusting setback

The bending leaf blade (7) must be adjusted for proper clearance, or “setback” (A, Figure 3) based on material thickness (B, Figure 3). Generally, setback for material within four gauges of capacity should be twice the thickness of material. For lighter gauges, use 1-1/2 times the material thickness. Consult a machinery handbook for bend allowances.

1. Loosen setback locking screws (5).
2. Rotate setback knobs (6) in equal amounts (clockwise decreases distance).

Note: When increasing distance (counterclockwise), you may have to pull back slightly on the bending leaf to take up any backlash.
3. Bring the clamping leaf into position and check the setback.
4. Repeat above steps until proper distance is achieved. Verify that bending leaf blade (7) is parallel to clamping fingers (2).
5. Tighten screws (5).

If a crown develops in the material, this can be adjusted out by loosening or tightening the hex nuts on the crown adjustment rod (12). Note: This rod has been correctly set by the manufacturer and should only be adjusted when needed.

8.2 Adjusting clamping pressure

Clamping pressure should be great enough to hold material securely, but not so much that it becomes difficult to clamp

Rotate clamping adjustment knobs (3) equally to set clamping pressure.

8.3 Repeat bends

Adjust stop bolt (4) to limit swing of bending leaf.

8.4 General procedure

1. Remove or add clamping fingers as needed for width of material and type of bend.
2. Adjust for setback and clamping pressure.
3. Position stop bolt if needed.
4. Align material in machine and press foot pedal until it locks.
5. Raise bending leaf to desired angle.

6. Lower bending leaf and press foot pedal lock to release material.

9.0 Maintenance

Daily wipe down machine with a soft rag.
Apply a light coat of SAE 30 oil to exposed metal surfaces to prevent rust.
Daily insert grease into the two fittings (14).

10.0 Troubleshooting

Trouble	Probable Cause	Remedy
Bends created with great difficulty.	Machine capacity exceeded.	Use material within capacity.
	Incorrect setback.	Increase setback.
Clamping leaf will not clamp properly.	Improper adjustment.	Decrease distance between fingers and beam.
	Clamping not even across width.	Rotate adjustment knobs equal amount.
Bend radius not consistent across material.	Machine capacity exceeded.	Use material within capacity.
	Bending leaf edge not parallel to fingers.	Adjust bending leaf equally on both ends.
	Bending leaf has crown.	Correct with crown adjustment rod.

Table 1

11.0 Replacement Parts

Replacement parts are listed on the following pages. To order parts or reach our service department, call 1-800-274-6848 Monday through Friday, 8:00 a.m. to 5:00 p.m. CST. Having the Model Number and Serial Number of your machine available when you call will allow us to serve you quickly and accurately.

11.1.1 Box and Pan Brake (40" model) – Exploded View

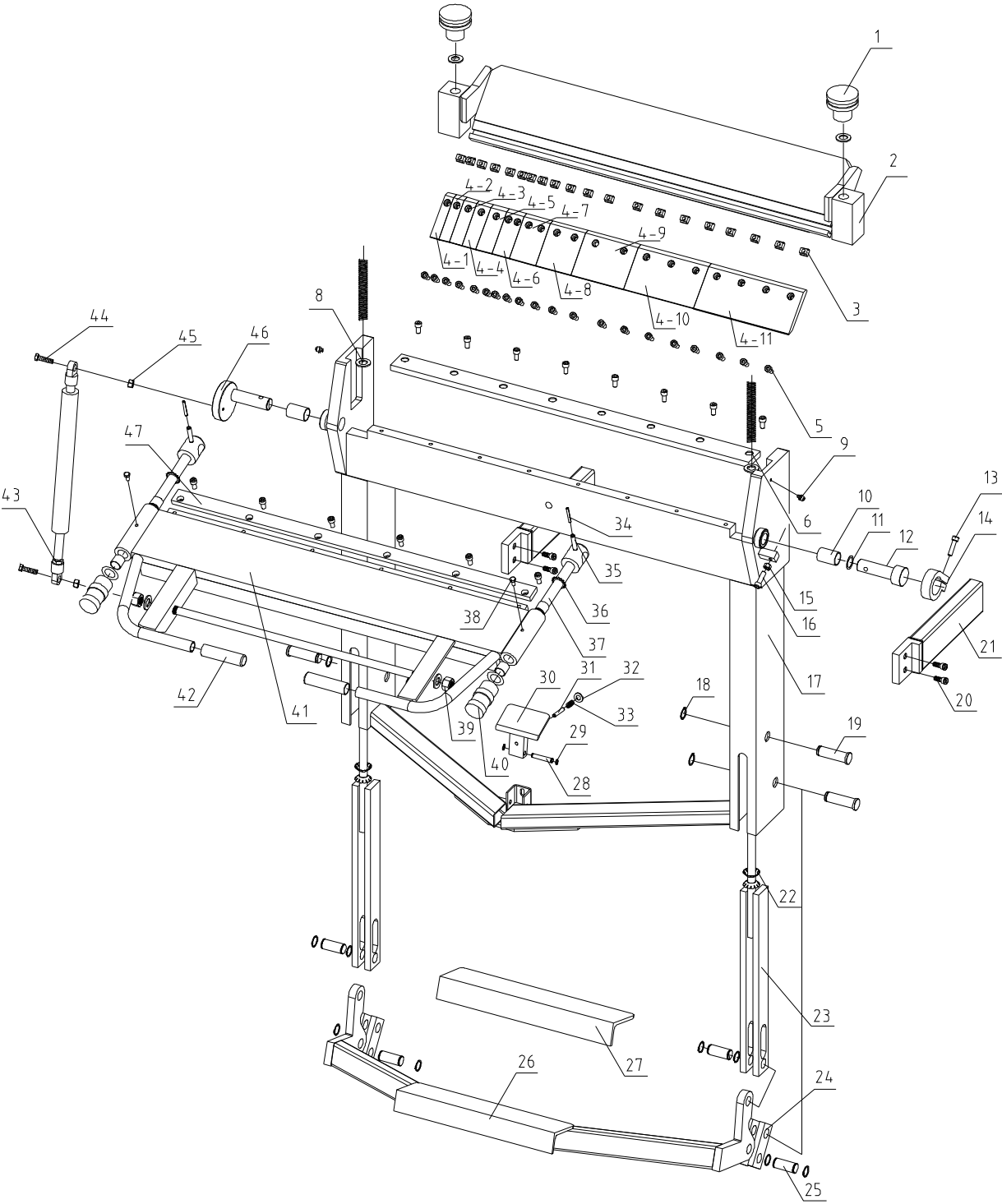

11.1.2 Box and Pan Brake (40" model) – Parts List

Index No.	Part No.	Description	Size	Qty
1	H40-210	Adjusting Nut		2
2	H40-215G	Clamping Leaf		1
3	H40-224	T-Nut		20
4-1	H40-201-1	Upper Finger	1"	1
4-2	H40-201-2	Upper Finger	1-1/8"	1
4-3	H40-201-3	Upper Finger	1-3/8"	1
4-4	H40-201-4	Upper Finger	1-1/2"	1
4-5	H40-201-5	Upper Finger	1-3/4"	1
4-6	H40-201-6	Upper Finger	2"	1
4-7	H40-201-7	Upper Finger	3"	1
4-8	H40-201-8	Upper Finger	4"	1
4-9	H40-201-9	Upper Finger	6"	1
4-10	H40-201-10	Upper Finger	7-3/4"	1
4-11	H40-201-11	Upper Finger	10-5/8"	1
5	TS-1505021	Socket Head Cap Screw	M10x20	34
6	H40-202	Clamping Block		1
7	H40-223	Adjusting Nut Spring		2
8	TS-155011	Flat Washer	20mm	6
9	BPF1240-9	Grease Fitting	M8x1	2
10	H40-227	Bushing		2
11	H40-226	Flat Washer		2
12	H40-209	Bending Leaf Pin		1
13	TS-1505051	Socket Head Cap Screw	M10x35	1
14	H40-204	Stop Collar		1
15	TS-1540071	Hex Nut	M10	1
16	TS-1505061	Socket Head Cap Screw	M10x40	1
17	H40-1020-04G	Leg		1
18	BPF1240-18	Ext. Retaining Ring	25mm	13
19	H40-208	Leg Pin		3
20	TS-1505041	Socket Head Cap Screw	M10x30	4
21	H40-217-3G	Extension Bracket		2
22	BPF1240-22	Disc Spring	Ø40xø20x1mm	4
23	H40-205	Rod		2
24	H40-206	Foot Pedal Lever		4
25	H40-207	Lever Pin		4
26	H40-216G	Foot Pedal		1
27	H40-402	Tread Plate Rubber		1
28	H40-211	Roll Pin		1
29	BPF1240-29	Ext. Retaining Ring	10mm	2
30	H40-213	Foot Pedal Lock		1
31	BPF1240-31	Spring Pin	8x50mm	1
32	TS-1550061	Flat Washer	8mm	1
33	H40-212	Pedal Lock Spring		1
34	BPF1240-34	Spring Pin	6x50mm	2
35	BPF1240-35	Spring Pin	10x50mm	2
36	BPF1240-36	O-Ring	25x3.55mm	2
37	H40-222	Setback Knob		2
38	TS-1490021	Hex Cap Screw	M8x16	2
39	TS-1540061	Hex Nut	M8	2
40	H40-221	Setback Knob		2
41	H40-218G	Bending Leaf		1
42	H40-401	Operating Handle		2
43	H40-1020-05	Air Spring	1500N	1
44	TS-2211451	Hex Cap Screw	M12x45	2
45	TS-1540081	Hex Nut	M12	2
46	H40-1020-00	Crank		1
47	H40-219	Bending Leaf Blade		1
48	BPF1240-WL	Warning Label (not shown)		1
49	JET-165	JET Logo (not shown)	165 x 68mm	1
50	LM000162	ID Label, BPF-1240 (not shown)		1

11.2.1 Box and Pan Brake (50" model) – Exploded View

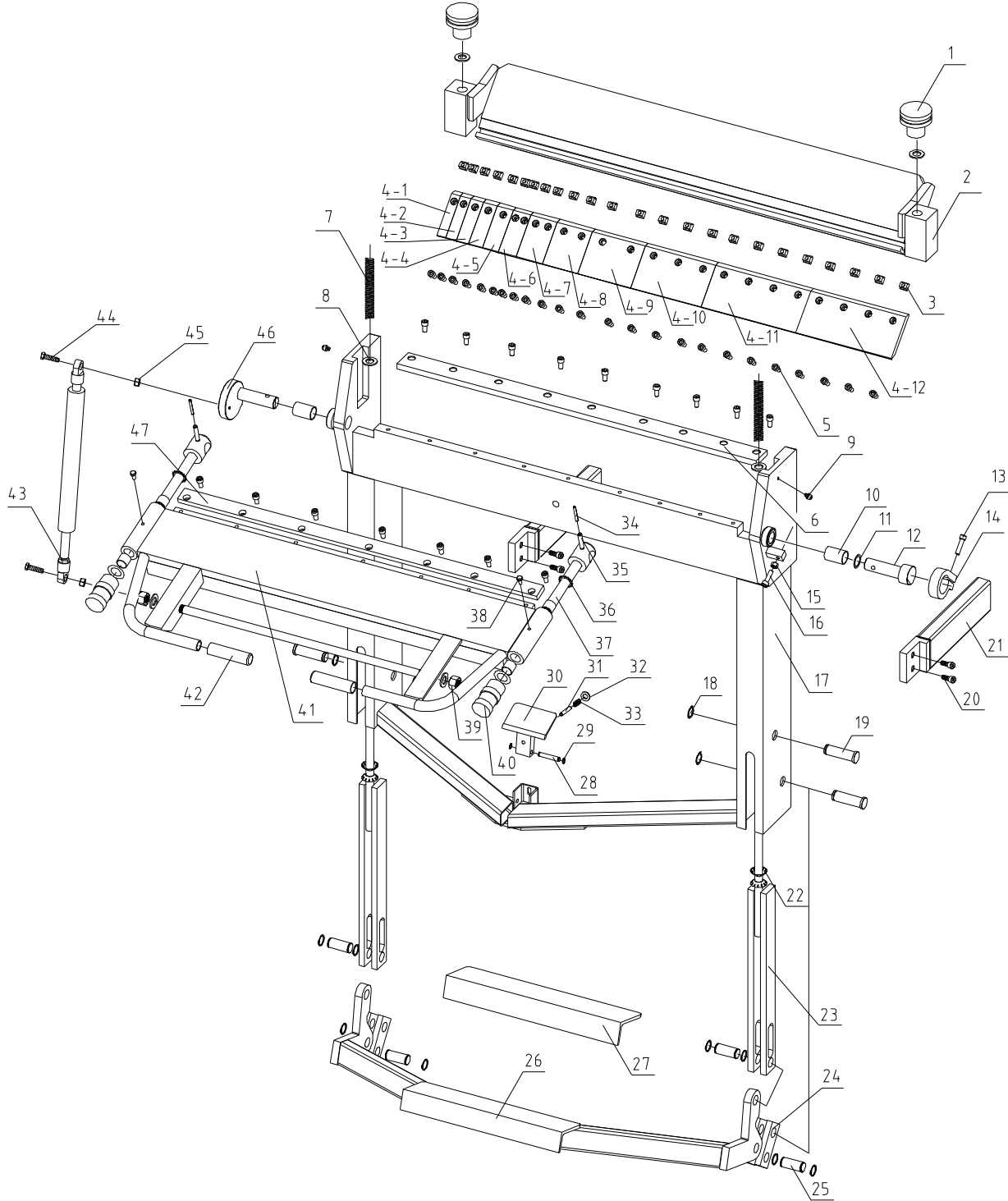

11.2.2 Box and Pan Brake (50" model) – Parts List

Index No.	Part No.	Description	Size	Qty
1	H40-210	Adjusting Nut		2
2	H50-215G	Clamping Leaf		1
3	H40-224	T-Nut		24
4-1	H40-201-1	Upper Finger	1"	1
4-2	H40-201-2	Upper Finger	1-1/8"	1
4-3	H40-201-3	Upper Finger	1-3/8"	1
4-4	H40-201-4	Upper Finger	1-1/2"	1
4-5	H40-201-5	Upper Finger	1-3/4"	1
4-6	H40-201-6	Upper Finger	2"	1
4-7	H40-201-7	Upper Finger	3"	1
4-8	H40-201-8	Upper Finger	4"	1
4-9	H40-201-9	Upper Finger	6"	1
4-10	H40-201-10	Upper Finger	7-3/4"	1
4-11	H50-201-11	Upper Finger	10"	1
4-12	H40-201-11	Upper Finger	10-5/8"	1
5	TS-1505021	Socket Head Cap Screw	M10x20	40
6	H50-202	Clamping Block		1
7	H50-223	Adjusting Nut Spring		2
8	TS-155011	Flat Washer	20mm	6
9	BPF1240-9	Grease Fitting	M8x1	2
10	H40-227	Bushing		2
11	H40-226	Flat Washer		2
12	H40-209	Bending Leaf Pin		1
13	TS-1505051	Socket Head Cap Screw	M10x35	1
14	H40-204	Stop Collar		1
15	TS-1540071	Hex Nut	M10	1
16	TS-1505061	Socket Head Cap Screw	M10x40	1
17	H50-1020-04G	Leg		1
18	BPF1240-18	Ext. Retaining Ring	25mm	13
19	H40-208	Leg Pin		3
20	TS-1505041	Socket Head Cap Screw	M10x30	4
21	H40-217-3G	Extension Bracket		2
22	BPF1240-22	Disc Spring	Ø40xø20x1mm	4
23	H40-205	Rod		2
24	H40-206	Foot Pedal Lever		4
25	H40-207	Lever Pin		4
26	H50-216G	Foot Pedal		1
27	H40-402	Tread Plate Rubber		1
28	H40-211	Roll Pin		1
29	BPF1240-29	Ext. Retaining Ring	10mm	2
30	H40-213	Foot Pedal Lock		1
31	BPF1240-31	Spring Pin	8x50mm	1
32	TS-1550061	Flat Washer	8mm	1
33	H40-212	Pedal Lock Spring		1
34	BPF1240-34	Spring Pin	6x50mm	2
35	BPF1240-35	Spring Pin	10x50mm	2
36	BPF1240-36	O-Ring	25x3.55mm	2
37	H40-222	Setback Knob		2
38	TS-1490021	Hex Cap Screw	M8x16	2
39	TS-1540061	Hex Nut	M8	2
40	H40-221	Setback Knob		2
41	H50-218G	Bending Leaf		1
42	H40-401	Operating Handle		2
43	H50-1020-05	Air Spring	1800N	1
44	TS-2211451	Hex Cap Screw	M12x45	2
45	TS-1540081	Hex Nut	M12	2
46	H40-1020-00	Crank		1
47	H50-219	Bending Leaf Blade		1
48	BPF1240-WL	Warning Label (not shown)		1
49	JET-165	JET Logo (not shown)	165 x 68mm	1
50	LM000163	ID Label, BPF-1450 (not shown)		1