



DAKE SEMI-AUTO MITERING BANDSAW

SE-6.5M

INSTRUCTIONAL MANUAL



WARNING!

Read and understand all instructions and responsibilities before operating. Failure to follow safety instructions and labels could result in serious injury.



Trick-Tools.com

75 Truman Road
Pella, IA 50219

Phone: 1-877-VAN-SANT

E-mail: sales@trick-tools.com





TABLE OF CONTENTS

DAKE STANDARD LIMITED WARRANTY.....	2
RETURN & REFUND POLICY	4
SPECIFICATIONS	5
SAFETY WARNINGS.....	6
MAIN MACHINE CONTROLS	9
SET UP	10
TRANSPORTATION OF MACHINE	10
ADJUSTMENTS.....	11
TOOTH SELECTION	11
BLADE SPEED	12
OPERATIONS.....	13
STARTING SAW	13
USAGE OF RAPID OPENING VISE	13
DOWN FEED CONTROLS	13
QUICK HEAD ADJUSTMENT FOR ANGLE CUTS	14
CUTTING SPEED ADJUSTMENT	15
MAINTENANCE	16
CHANGING BLADE	16
TROUBLESHOOTING	17
ELECTRICAL DIAGRAM	19
EXPLODED VIEWS & PART LIST	20
ORDERING INFORMATION	21



DAKE STANDARD LIMITED WARRANTY

Finished Machines

Dake warrants to the original purchaser the finished machine manufactured or distributed by it to be free from defects in material and workmanship under normal use and service within 1 year (12 months) from the delivery date to the end user.

Parts

Dake warrants to the original purchaser the component part manufactured or distributed by it to be free from defects in material and workmanship under normal use and service within 30 days from the delivery date to the end user.

The standard limited warranty includes the replacement of the defective component part at no cost to the end user.

Sale of Service (Repairs)

Dake warrants to the original purchaser the component part repaired by Dake Corporation at the manufacturing facility to be free from defects in material and workmanship under normal use and service within 90 days from the return date to the end user, as it pertains to the repair work completed. The standard limited warranty includes repair of the defective component part, at no cost to the end user.

Warranty Process

Subject to the conditions hereinafter set forth, the manufacturer will repair or replace any portion of the product that proves defective in materials or workmanship. The manufacturer retains the sole right and option, after inspection, to determine whether to repair or replace defective equipment, parts or components. The manufacturer will assume ownership of any defective parts replaced under this warranty.

All requested warranty claims must be communicated to the distributor or representative responsible for the sale. Once communication has been initiated, Dake Customer Service must be contacted for approval:

Phone: (800) 937-3253

Email: customerservice@dakecorp.com

When contacting Dake, please have the following information readily available:

- Model #
- Serial #
- Sales Order #

Purchasers who notify Dake within the warranty period will be issued a Case number and/or a Return Material Authorization (RMA) number. If the item is to be returned per Dake's request, the RMA number must be clearly written on the exterior packaging. Any item shipped to Dake without an RMA will not be processed.

**Warranty Exceptions:**

The following conditions are not applicable to the standard limited warranty:

- (a) Part installation or machine service was not completed by a certified professional, and is not in accordance with applicable local codes, ordinances and good trade practices.
- (b) Defects or malfunctions resulting from improper installation or failure to operate or maintain the unit in accordance with the printed instructions provided.
- (c) Defects or malfunctions resulting from abuse, accident, neglect or damage outside of prepaid freight terms.
- (d) Normal maintenance service or preventative maintenance, and the parts used in connection with such service.
- (e) Units and parts which have been altered or repaired, other than by the manufacturer or as specifically authorized by the manufacturer.
- (f) Alterations made to the machine that were not previously approved by the manufacturer, or that are used for purposes other than the original design of the machine.



RETURN & REFUND POLICY

Thank you for purchasing from Dake! If you are not entirely satisfied with your purchase, we are here to help.

Returns

All Dake manufactured / distributed machines, parts and couplings include a 30-day return option. These policies are valid from the date of final shipment to the end user.

To be eligible for a return, the item must be unused and in the same condition as received.

All requested warranty claims must be communicated to the distributor or representative responsible for the sale. Once communication has been initiated, Dake Customer Service must be contacted for approval:

Phone: (800) 937-3253

Email: customerservice@dakecorp.com

Once the return request has been approved by Customer Service, a representative will supply a Return Material Authorization (RMA) number. The returned item must have the provided RMA number clearly marked on the outside packaging. Any item received without an RMA number clearly visible on the packaging will not be processed.

An RMA number can only be provided by the Dake Customer Service team and must be obtained prior to the return shipment.

Refunds

Once the item has been received and inspected for damages, a representative will notify the requestor referencing the provided RMA number.

If the return is approved, a refund will be issued to the original method of payment, less a 20% restocking fee. The restocking fee may be waived if an order is placed at the time of return with like-value merchandise.

Transportation costs are the responsibility of the end user and will not be credited upon return approval.

Any item that is returned after the initial 30 days or has excessive/obvious use will not be considered for a full refund.



SPECIFICATIONS

Machine Type	Hydraulic controlled feed horizontal mitering band saw
Blade Size	84-1/4" x 3/4"
Blade Speed	114-263 FPM
Head Feed	Hydraulic controlled down feed
Vise	Manual with quick opening release
Miter Cutting Capabilities	Up to 60° right
Controls	CE Certified
Horsepower	2.5
Weight	308 lbs
Work Height	37"
Overall Height, Open / Closed	65" open / 52" closed
Base Width	25"
Depth	48"
Lubricant	Flood type unit build into the machine (Electric)
Voltage	120V (Machine should be wired to main service by a qualified electrician)

CUTTING CAPACITIES

Degree	Round	Square	Flat
90°	6-1/2"	6-3/4"	7-3/4"
60°	3"	3"	4 x 2-3/4"
45°	4-1/4"	4-1/2"	6 x 4-1/4"

In the space provided record the serial number and model number of the machine. This information is only found on the black Dake tag. If contacting Dake this information must be provided to assist in identifying the specific machine.

Model No: SE-6.5M

Part No: 983110

Serial No:

Date of Purchase:



SAFETY WARNINGS



**WARNING: FAILURE TO FOLLOW THESE RULES
MAY RESULT IN SERIOUS PERSONAL INJURY**



WARNING: This product contains Nickel, a chemical known to the State of California to cause cancer. For more information go to www.P65Warnings.ca.gov

As with all machinery there are certain hazards involved with operation and use of the machine. Using the machine with respect and caution will considerably lessen the possibility of personal injury. However, if normal safety precautions are overlooked or ignored, personal injury to the operator may result.

This machine was designed for certain applications only. We strongly recommend that this machine NOT be modified and/or used for any application other than for which it was designed. If you have any questions relative to its application DO NOT use the machine until you contact with us and we have advised, you.

Your machine might not come with a power socket or plug. Before using this machine, please ask your local electrician to install the socket or plug on the power cable end.

SAFETY RULES FOR ALL TOOLS

USER:

- Wear proper apparel: No loose clothing, gloves, rings, bracelets, or other jewelry to get caught in moving parts. Non-slip foot wear is recommended. Wear protective hair covering to contain long hair.
- Always wear eye protection. Refer to ANSLZ87.1 standard for appropriate recommendations. Also use face or dust mask if cutting operation is dusty.
- Do not overreach. Keep proper footing and balance at all times.
- Never stand on the machine. Serious injury could occur if the machine is tipped or if the cutting blade is accidentally contacted.
- Never leave the saw running unattended. Turn off power. Don't leave saw until it comes to a complete stop.
- Do not operate the tool while under the influence of drugs, alcohol, or any medication.
- Make sure the saw is disconnected from power supply while motor is being mounted, connected, or reconnected.
- Always keep hands and fingers away from table.
- Stop the machine before removing any chips or debris.
- Shut off power and clean the band saw and work area before leaving machine.



USE OF MACHINE:

- Remove adjusting keys and wrenches. Form a habit of checking to see that keys and adjusting wrenches are removed from the saw before turning it on.
- Do not force the saw. It will do a more efficient and safer job at the rate for which it was designed.
- Use correct blade. Do not force blade or attachments to do a job for which it was not designed.
- Secure work. Use clamps or a vise to hold work when practical. It is safer than using your hands.
- Maintain blade is in top condition. Keep blades sharp and clean for best and safest performance. Follow instructions for lubricating and changing accessories.
- Use recommended accessories. Consult the owner's manual for recommended accessories. The use of improper accessories may cause hazards.
- Avoid accidental starting. Make sure the switch is in the "OFF" position before plugging in the cord.
- Direction of feed. Feed work into the blade against the direction of rotation of the blade.
- Adjust and position the blade guide arm before starting the cut.
- Keep blade guide arm tight. A loose blade guide arm will affect sawing accuracy.
- Make sure blade speed is set correctly for material being cut.
- Check for proper blade size and type.
- Stop the machine before putting material in the vise.
- Always have stock firmly clamped in vise before starting the cut.
- Ground all tools. If tool is equipped with three-prong plug, it should be plugged into a three-hole electrical receptacle, the adapter plug must be attached to a known ground. Never remove the third prong.

ADJUSTMENTS:

- Make all adjustments with the power off. In order to maintain the machine, precision and correct ways of adjustment while assembling, the user should read the detailed instruction in this manual.

WORKING ENVIRONMENT:

- Keep work area clean. Cluttered areas and benches invite accidents.
- Do not use in dangerous environment. Do not use power tools in damp or wet locations or expose them to rain. Keep work area well-lighted.
- Keep children and visitors away. All children and visitors should be kept a safe distance from work area.
- Do not install or use this machine in an explosive, dangerous environment.



MAINTENANCE:

- Disconnect machine from power source when making repairs.
- Check damaged parts. Before further use of the saw, a guard or other part that is damaged should be carefully checked to ensure that it will operate properly and perform its intended function check for alignment of moving parts, binding of moving parts, breakage of parts, mounting, and any other condition that may affect its operation. A guard or other part that is damaged should be properly repaired or replaced.
- Disconnect tools before servicing and when changing accessories such as blades, bits, cutters, etc.
- Make sure that the blade tension is properly adjusted. Green LED will light when properly tensioned. Saw will not operate until green light is lit.
- Re-check blade tension after initial cut with new blade.
- To prolong blade life always releases blade tension at the end of each work day.
- Check coolant daily. Low coolant level can cause foaming and high blade temperatures. Dirty or weak coolant can clog pump. This can cause low cutting rate and permanent blade failure. Dirty coolant can cause the growth of bacteria with ensuring skin irritation.
- When cutting magnesium never use soluble oils or emulsions (oil-water mix) as water will greatly intensify any accidental magnesium chip fire. See your industrial coolant supplier for specific coolant recommendations when cutting magnesium.
- To prevent corrosion of machined surfaces when a soluble one is used as coolant, pay particular attention to wiping dry the surfaces where fluid accumulates and does not evaporate quickly, such as between the machine bed and vise.

SPECIFIC USAGE:

This machine is used for general metals cutting within the range of cutting capacity.

SAFETY DEVICE:

By the time the saw arm cover is opened, the interlock switch will function to stop the all involvement. Do not remove this switch from machine for any reason and check its function frequency.



MAIN MACHINE CONTROLS

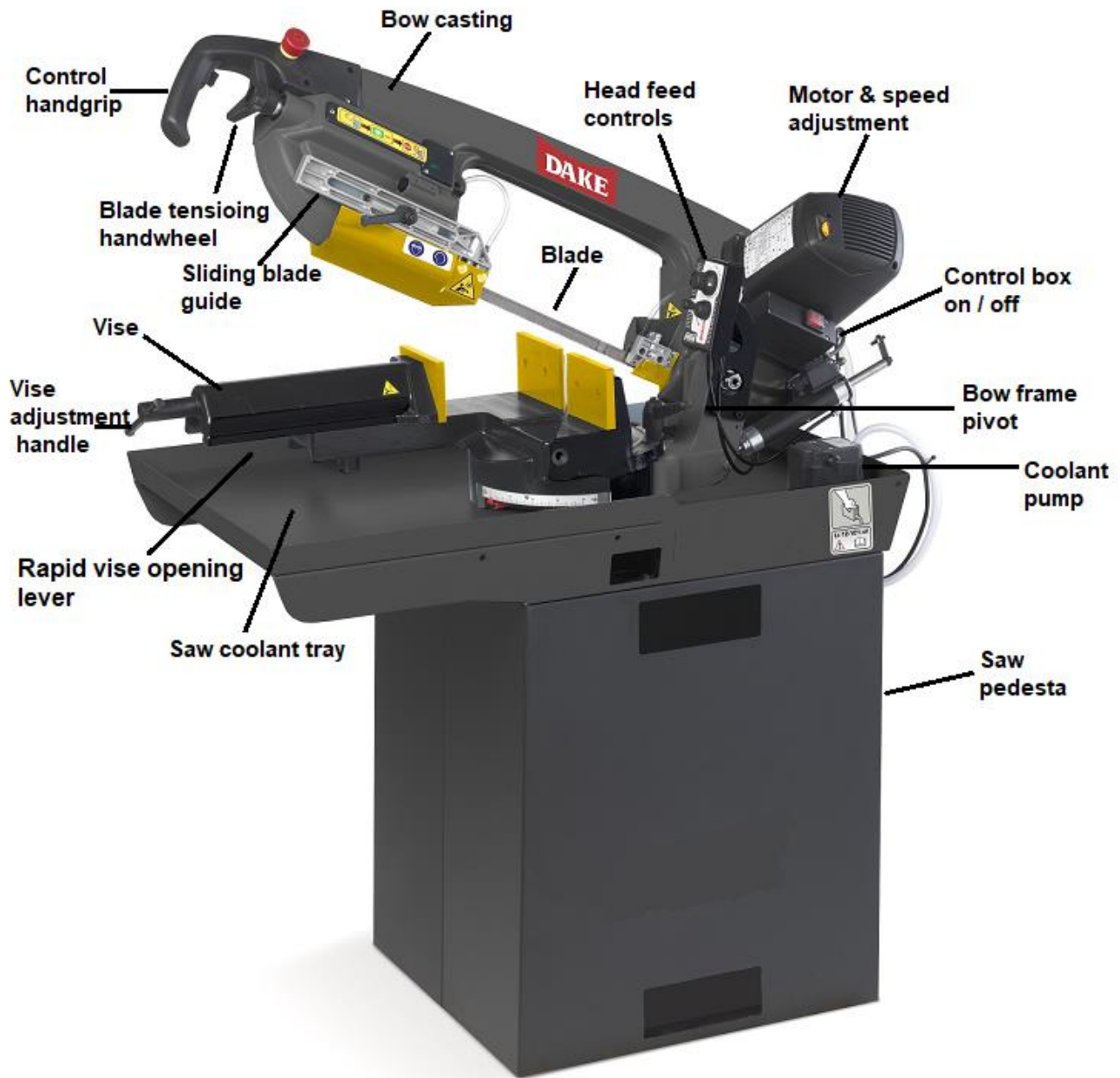



SET UP

TRANSPORTATION OF MACHINE

This machine weighs 300lbs.

Transport to desired location before unpacking, please use lifting jack.

Transportation after unpacking, please use heavy duty fiber belt to lift up the machine.

Always keep proper footing and balance while moving this machine.

Minimum space required for machine operation below:

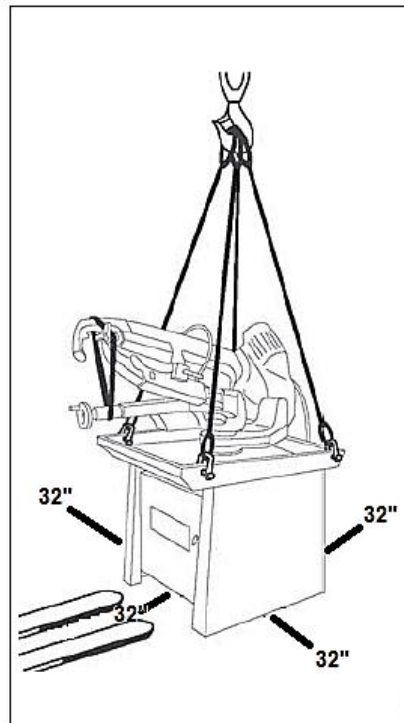

INSTALLATION:

Assemble saw pedestal and bolt saw on the pedestal.

1. Tighten all locks before operation.
2. Turn off the power before wiring, and be sure machine is properly grounded. Overload and circuit breakers are recommended for safety wiring.
3. Check carefully if the saw blade is running in counterclockwise direction, if not, reverse the wiring per circuit diagram then repeat running test.

ADJUSTMENTS

TOOTH SELECTION

For maximum cutting efficiency and lowest cost per cut, it is important to select the blade with the right number of teeth per inch for the material being cut. The material size and shape dictate tooth selection.

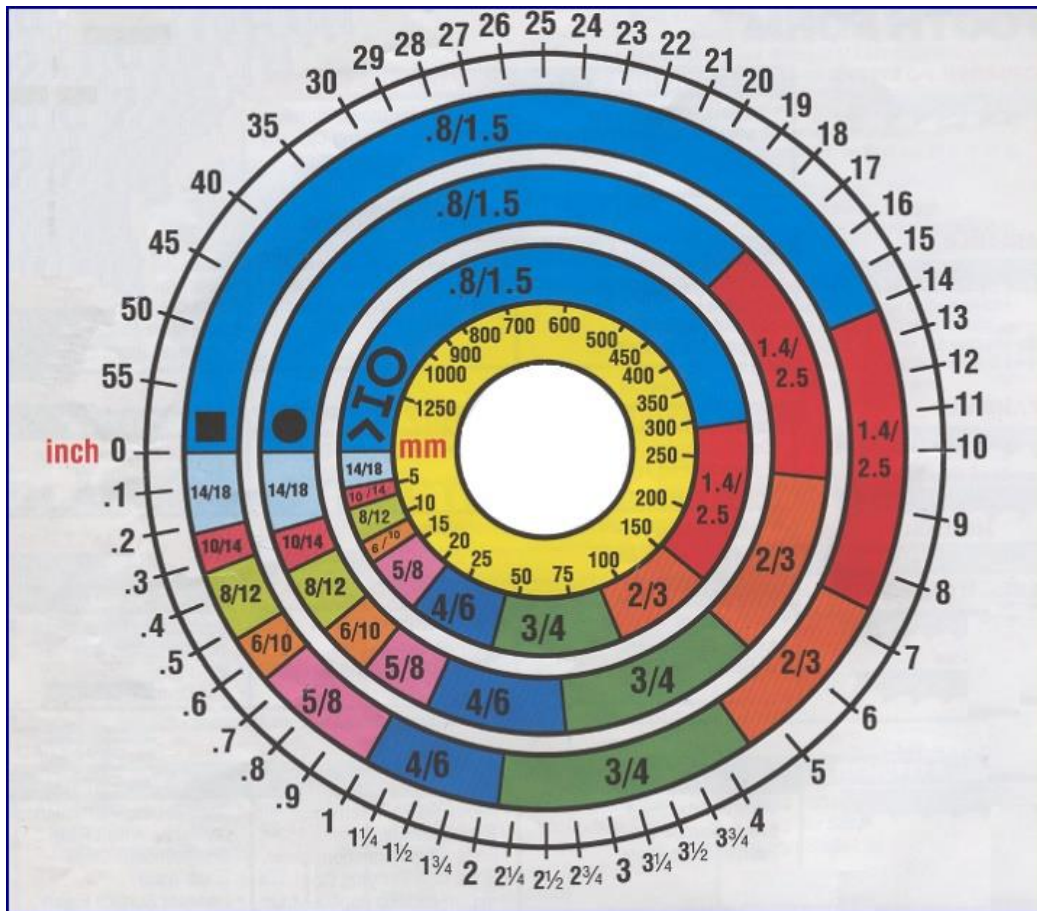

You need to consider:

The width of the cut. That is, the distance in the cut that each tooth must travel from the point it enters the work piece until it leaves the work piece, and the shape of the work piece. Use the chart above to assist with tooth selection.

- Squares, Rectangles, Flats (Symbol: ■)
 Locate the width of your work piece on the chart. (Inches on the outer circle and millimeters on the inner circle.) Select the tooth pitch on the ring marked with square which aligns with the width of the cut.
 Example: 6" (150mm) square, use a 2/3 Vari-Tooth.

- Round Solids (Symbol: ●)

Locate the diameter of your work piece on the chart. Select the tooth pitch on the ring marked with the circle which aligns with the size of stock you are cutting.

Example: 4" (100mm) round, use a 3/4 Vari-Tooth.

- Tubing, Pipe, Structural (Symbols: O, H, ^)

Determine the average width of cut by dividing the area of the work piece by the distance the saw blade must travel to finish the cut. Select the tooth pitch on the ring marked with the tubing and structural shape which aligns with the average width you are cutting.

Example: 4" (100mm) outside diameter, 3" (75mm) inside diameter tubing.

$$\begin{array}{rcl}
 4" (100\text{mm}) \text{ OD} & = & 12.5 \text{ in}^2 (79 \text{ cm}^2) \\
 3" (75 \text{ mm}) \text{ ID} & = & 7.0 \text{ in}^2 (44 \text{ cm}^2) \\
 \hline
 \text{Area} & = & 5.5 \text{ in}^2 (35 \text{ cm}^2)
 \end{array}$$

$5.5 \text{ in}^2 (35 \text{ cm}^2) / 4" (100\text{mm}) \text{ distance} = 1.38" (35 \text{ mm}) \text{ average width}$ 1.38" (35 mm), use a 4/6 Vari-Tooth.

BLADE SPEED

The band speeds are to be used as a starting point for most application. For exact parameters consult your saw blade supplier.

Material	Speed (FPM)
Tool, Stainless, Alloy Steels, Bearing Bronze	114
Med. to High Carbon Steels, Hard Brass or Bronze	130
Low to Med. Carbon Steel, Soft Brass	180
Aluminum, Plastic	262

TELLTALE CHIPS

Chips are the best indicator of correct feed force. Monitor chip information and adjust feed accordingly.

Thin or powdery chips – increase feed rate or reduce band speed.

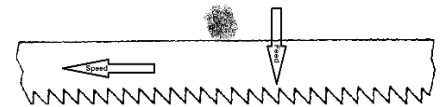

Burned heavy chips – reduce feed rate and/or band speed.

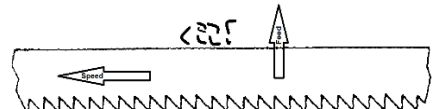

Curly silvery and warm chips – optimum feed rate and band speed.

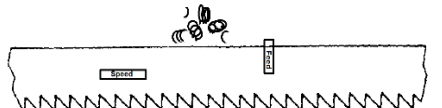

OPERATIONS

STARTING SAW

Trigger switch and lock button located on handle of the saw used for starting the saw in manual or semi-automatic mode.

USAGE OF RAPID OPENING VISE

The workpiece is placed between the vise jaws with the amount to be cut off extending out past the blade. Your machine is equipped with a “rapid vise jaw” which allows you to instantly position the movable vise jaw. This is for quick change over a different material. Simply release the lever located under the vise and move the vise jaw open or closed to the desired position. Then tighten the lever. Adjust vise normally.



DOWN FEED CONTROLS

This control regulates the speed at which the head descends and pressure. When the head lock control is all the way to the left it locks the head at any height chosen. Rotating the lever down or in any position in between allows the head to descend allowing for regulated cutting pressure.

The upper rotary control “head down feed control” varies the speed at which the head descends during the cut. The dial with numbers corresponds to the speeds and feed recommendations listed on the motor label. Turn the dial to a higher number to increase the down feed speed.

Note: If cutting in manual mode, both of these controls are to be set at their maximum settings. Be careful not to let go of the cutting head which can drop and cause injury.

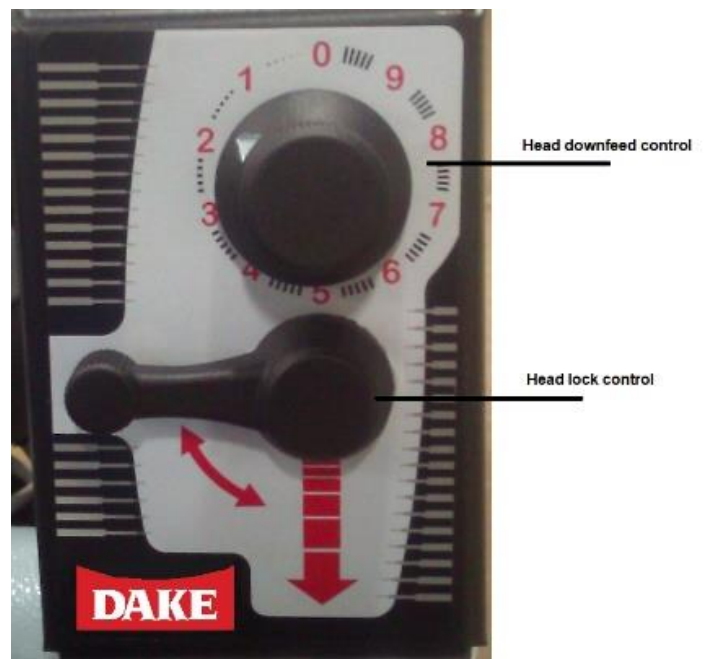



QUICK HEAD ADJUSTMENT FOR ANGLE CUTS

1. Loosen the head swivel lock handle.
2. Rotate head to the required angle by aligning indicator to the scale. Three presets can be used, or any angle in between.
3. Lock head back down.

For mitering beyond 45° slide the cam located on the left side attached to the swivel. Loosen the handle and slide the cam to allow for greater angles. This can also be used to adjust angles if needed.



Miter scale. Preset stops at 0-45-60 degree angles.

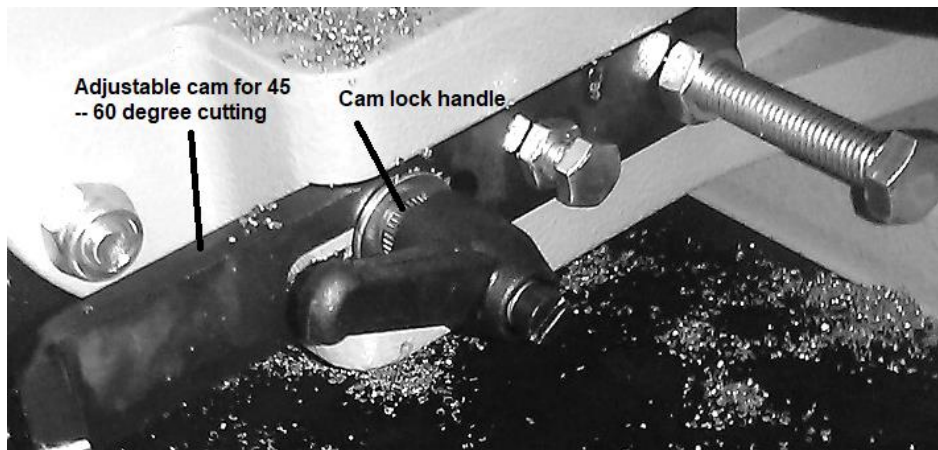



CUTTING SPEED ADJUSTMENT

The motor speed selection chart can help you figure out the best speeds for the material, blade recommendation, head feed range and corresponding reference number for the speed adjusting wheel. These are good starting points.

Always allow the blade to achieve speed before starting your cut. This saw incorporates "constant speed control" to prevent bog downs when cutting.





MAINTENANCE



CAUTION - WARNING

Make certain that the unit is disconnected from the power source before attempting to service or remove any component.

It is easier to keep the machine in good condition or best performance by means of maintaining it at any time than remedy it after it is out of order.

Regular Maintenance Schedule:

Daily	Check and fill cutting fluid if needed, before starting the machine every day. Water soluble cutting fluid is recommended. Avoid cutting oils.
	If there is a strange or unusual noise or malfunction, stop the machine immediately to check it for the problem source. Repairs must be made by qualified personnel before continuing use.
	Clean work area.
Weekly	Clean and coat any machines surfaces with oil to prevent rust.
	Check to see if sliding surfaces and turning parts lack of lubricant. If lubrication is insufficient, fill it.
Monthly	Check electrical cord, plugs, switched at least once a month to avoid loosening or wearing.

CHANGING BLADE

Check the compatibility of the NEW blade for the saw. Only use a blade with a thickness between .025" and .035".

Raise saw head to upper most position and open the blade guards. Loosen tension screw knob sufficiently to allow the saw blade to slip off the wheels. Install the new blade with the teeth slanted toward the motor as follow:

1. Place the blade in between each of the guide bearings.
2. Slip the blade around the motor wheel (rear) with the left hand and hold on position.
3. Hold the blade taut against the motor wheel by pulling the blade towards the front wheel with the right hand and adjust the position of the front wheel by slipping the blade around the wheel using thumb, index, and little finger as guides.
4. Adjust the blade tension knob clockwise until the green LED is lit on the no/go tensioning gauge. Do not tighten excessively.
5. Replace the blade guards. Rear blade cover has interlocks and will not allow the saw to run without these interlocks engaged.

TROUBLESHOOTING

SYMPTOM	POSSIBLE CAUSE	CORRECTIVE ACTION
Excessive Blade Breakage	<ol style="list-style-type: none"> 1. Materials loosen in vise. 2. Incorrect speed or feed. 3. Blade teeth spacing too large. 4. Material too coarse for blade. 5. Incorrect blade tension. 6. Teeth in contact with material before saw is started. 7. Blade runs on wheel flange. 8. Miss-aligned guide bearings. 9. Blade is too thick. 10. Cracking at weld. 	<ol style="list-style-type: none"> 1. Clamp work securely. 2. Adjust speed or feed. 3. Replace with a finer tooth spacing blade. 4. Use a blade at slower speed with proper teeth spacing. 5. Adjust to where the green LED lights up. 6. Place blade in contact with work after motor is started. 7. Adjust wheel alignment. 8. Adjust guide bearings. 9. Use a thinner grade. 10. Reweld blade.
Premature Blade Dulling	<ol style="list-style-type: none"> 1. Teeth too coarse. 2. Blade speeds too fast. 3. Inadequate feed pressure. 4. Hard spots or scale on material. 5. Work hardening of material. 6. Blade twist. 7. Insufficient blade tension. 8. Blade slips. 	<ol style="list-style-type: none"> 1. Use finer teeth. 2. Reduce speed. 3. Adjust pressure setting. 4. Reduce speed, increase feed pressure. 5. Increase feed pressure. 6. Replace with a new blade and adjust blade tension. 7. Tighten blade tension adjustment knob. 8. Tighten blade tension.
Unusual Wear on Side/Back of Blade.	<ol style="list-style-type: none"> 1. Blade guides worn. 2. Blade guides not adjusted properly. 3. Blade guides are loose. 	<ol style="list-style-type: none"> 1. Replace. 2. Adjust. 3. Tighten.
Teeth Ripping from Blade	<ol style="list-style-type: none"> 1. Tooth too coarse for work. 2. Too heavy of pressure; too slow of speed. 	<ol style="list-style-type: none"> 1. Use finer tooth blade. 2. Decrease pressure, increase speed.

	3. Vibrating workpiece. 4. Gullets loading up.	3. Clamp workpiece securely. 4. Use coarser tooth blade or brush to remove chips.
--	---	--

SYMPTOM	POSSIBLE CAUSE	CORRECTIVE ACTION
Bad Cuts (Crooked)	1. Feed pressure too great. 2. Guides not adjusted properly. Too far from work. 3. Inadequate blade tension. 4. Dull blade. 5. Blade speed is incorrect. 6. Blade guide assembly loose. 7. Blade tracking too far away from wheels.	1. Reduce pressure. 2. Adjust guides closer to work. 3. Increase blade tension. 4. Replace blade. 5. Adjust speed. 6. Tighten. 7. Re-track blade.
Bade Cuts (Rough)	1. Too much speed or feed. 2. Blade is too coarse. 3. Blade tension loose.	1. Decrease speed or feed. 2. Replace with finer blade. 3. Adjust blade tension.
Blade is twisting.	1. Cut is binding blade. 2. Too much blade tension	1. Decrease feed pressure 2. Decrease blade tension.

ELECTRICAL DIAGRAM

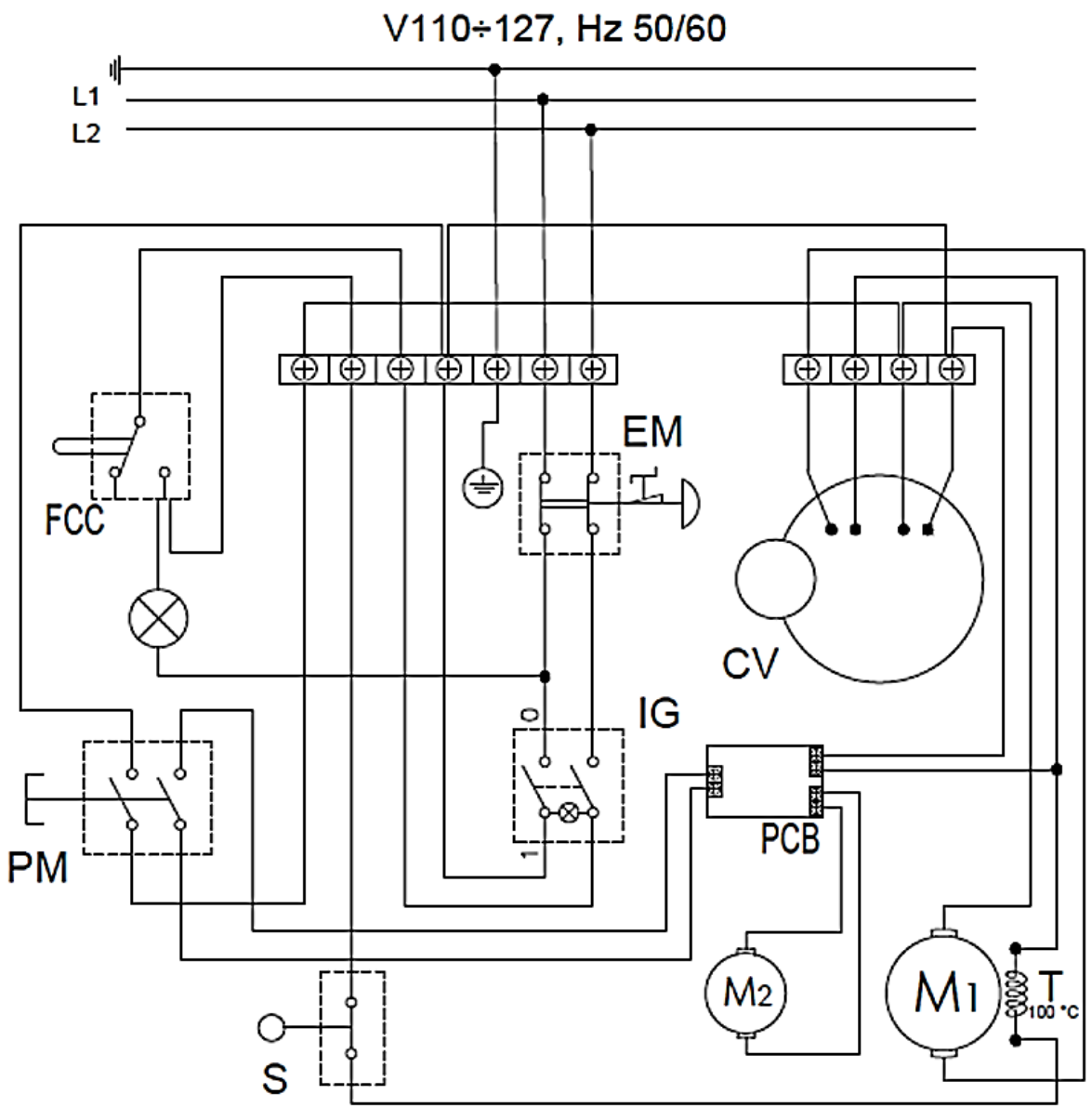

EXPLODED VIEWS & PART LIST

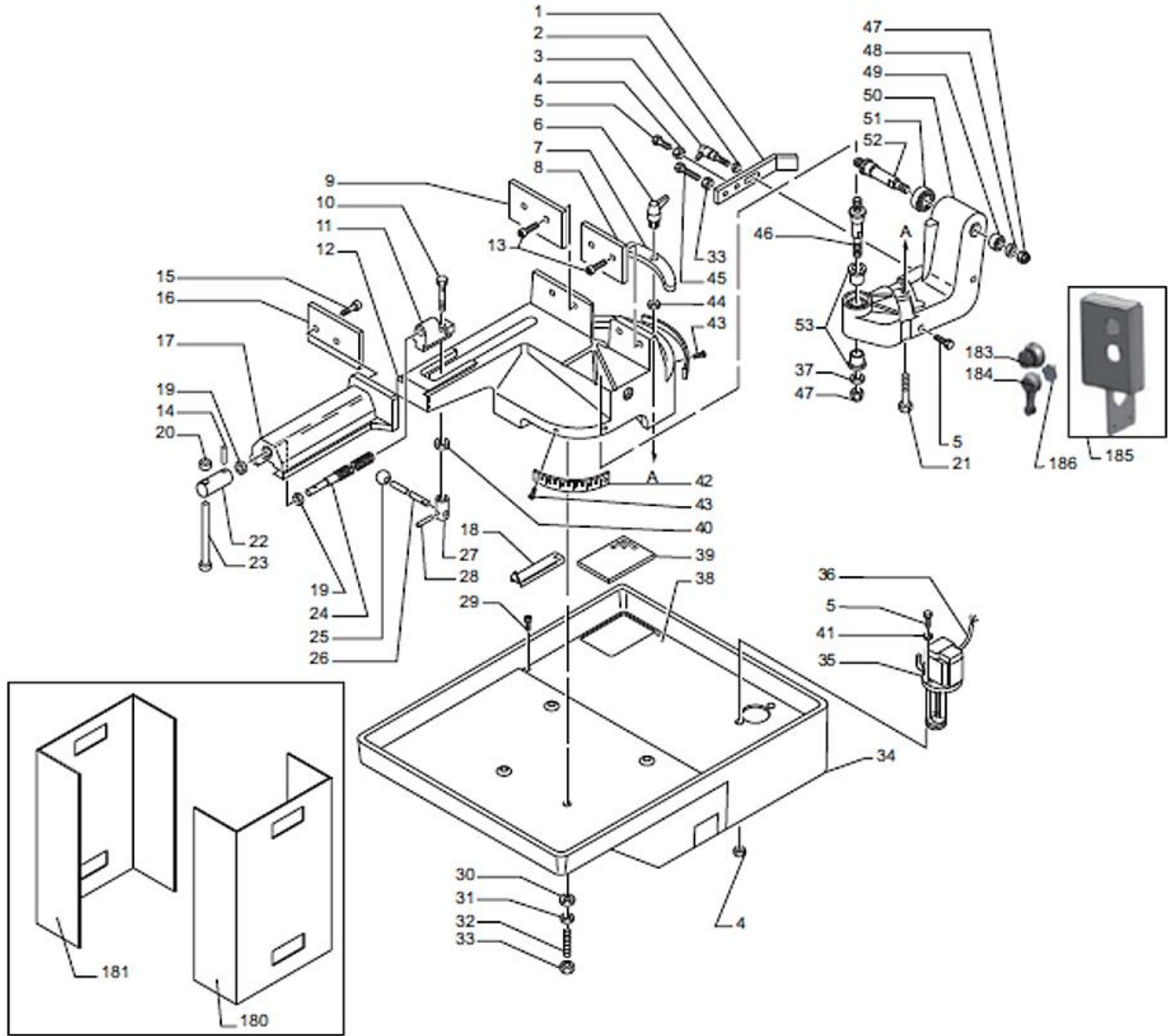

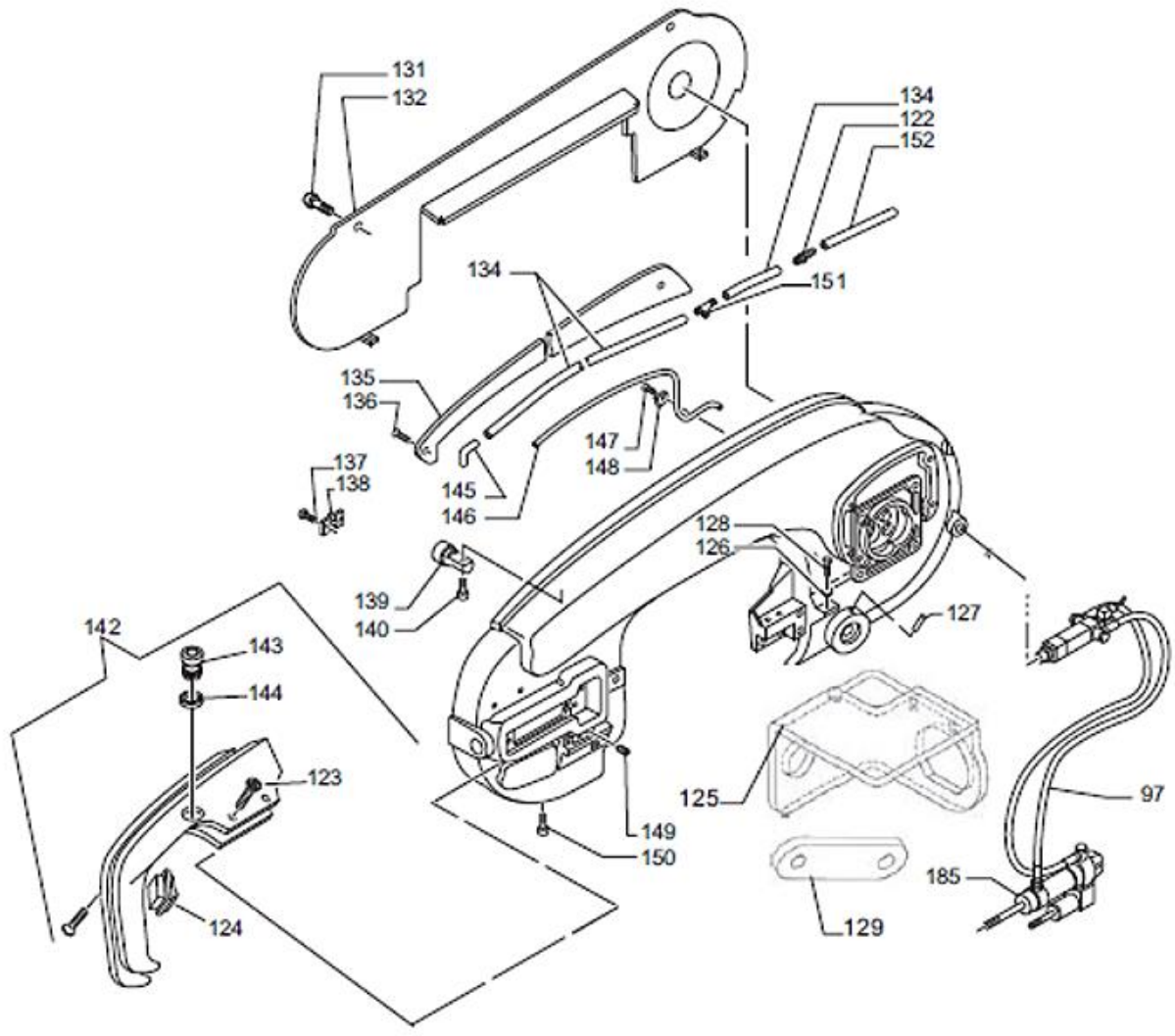

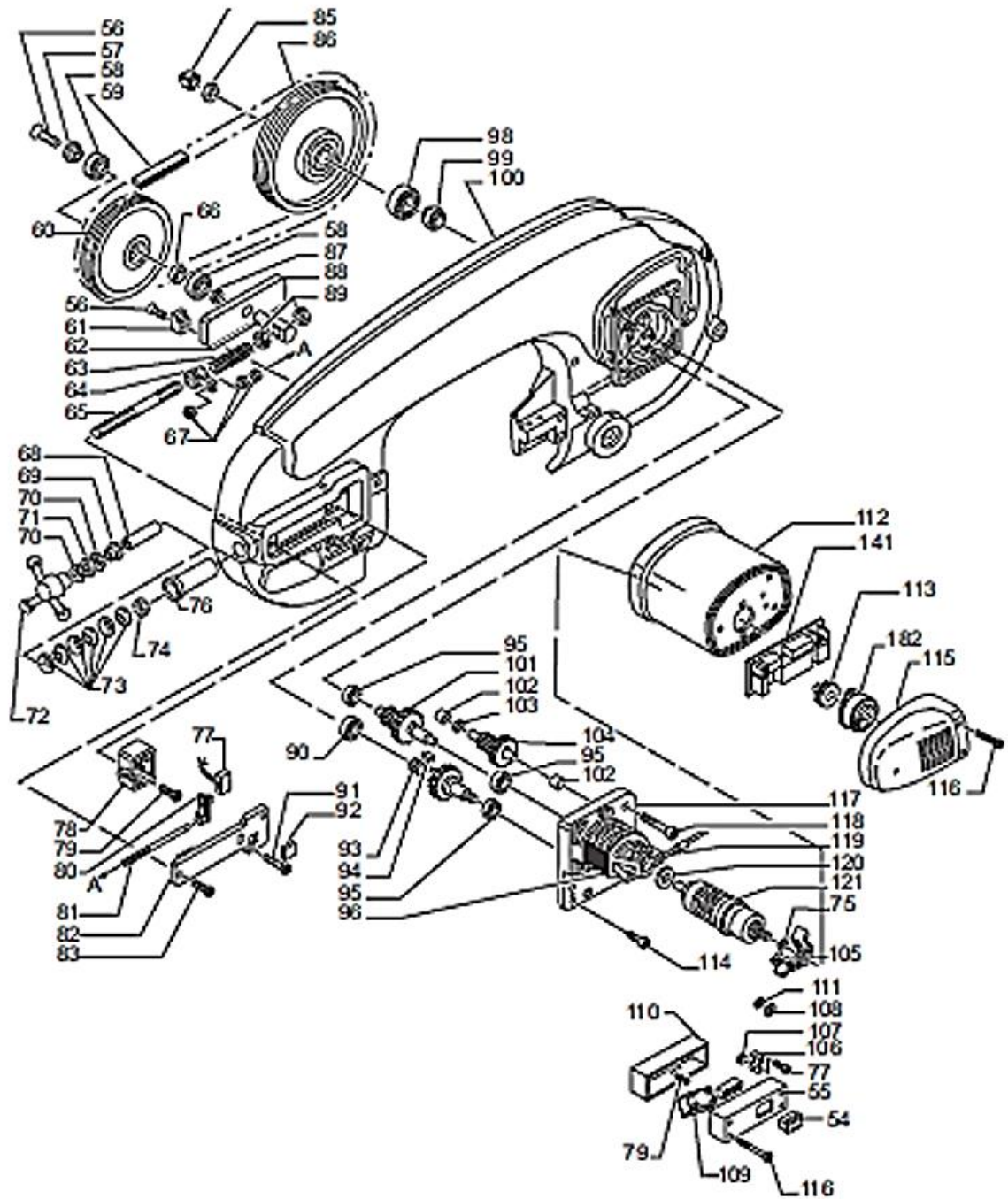

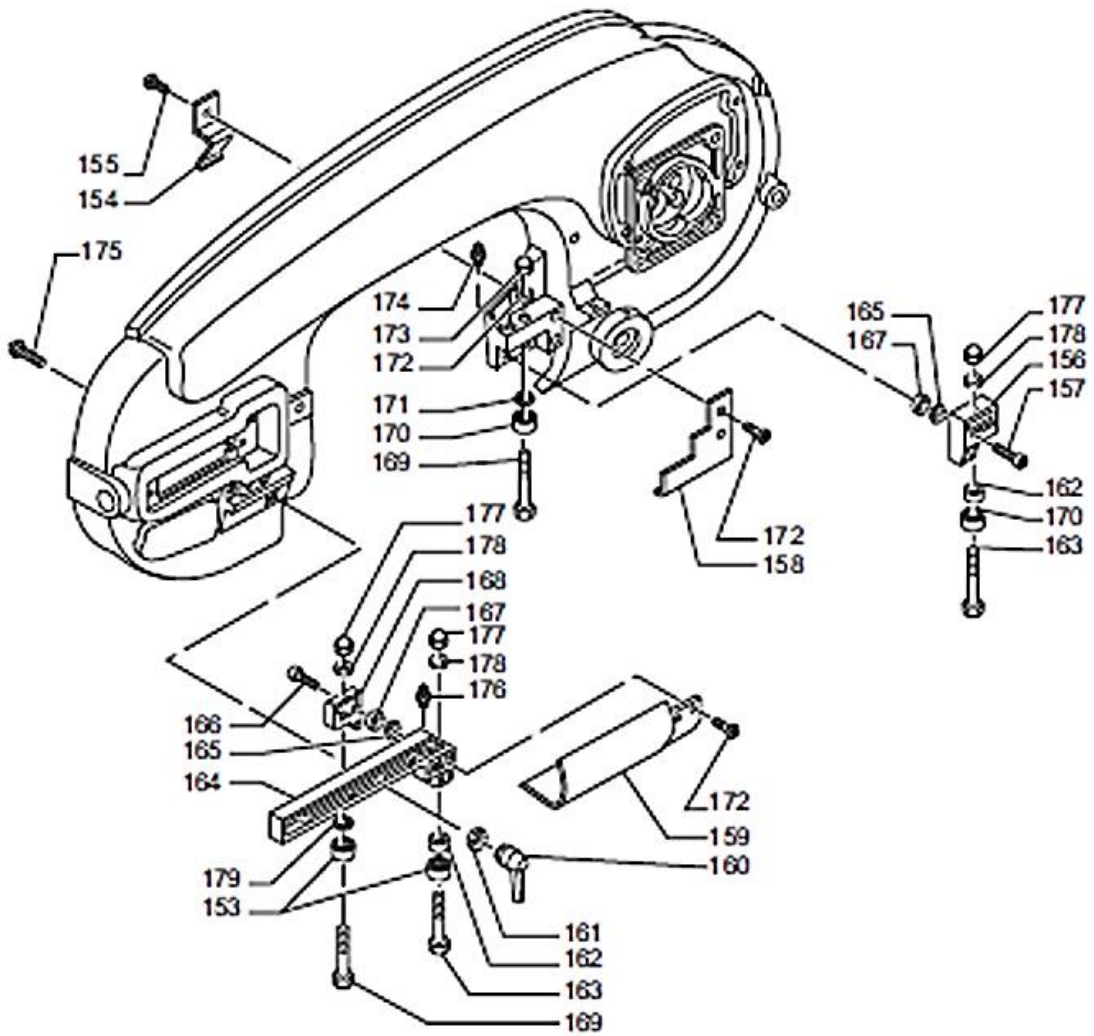

Pos.	Description	Part #
1	5.13.07.96	
2	UNI 6592 Ø 6,5x18	
3	0.14.70.07	
4	UNI5588 M6	
5	UNI 5737 M6x20	
6	0.14.70.17	
7	5.18.25.32	
8	5.15.25.94	
9	5.15.25.95	
10	UNI 5732 M14x70	
11	5.13.08.64	
12	5.13.79.63	
13	UNI 5931 M8x20	
14	0.15.26.30	
15	UNI 5931 M8x20	
16	5.15.26.11	
17	5.13.08.63	
18	Index	303393
19	UNI 6592 Ø14	
20	0.14.00.59	
21	UNI 5739 M12x50	
22	5.17.10.40	
23	5.14.20.23	
24	5.10.03.34	
25	0.14.00.73	
26	5.14.20.90	
27	5.17.10.35	
28	0.15.24.30	
29	UNI 6954 P8x9,5	
30	5.12.40.33	
31	0.12.07.08	
32	UNI 5923 M8x35	
33	UNI 5588 M8	
34	5.13.38.03	
35	Coolant pump	303392
36	5.87.10.72	
37	UNI 6592 Ø16	
38	5.18.25.33	
39	Coolant tank filter	303391
40	5.12.40.56	

Pos.	Description	Part #
41	UNI 6592 Ø6	
42	Graduate plate	303471
43	0.40.29.05	
44	0.12.40.32	
45	UNI 5737 M8x50	
46	5.17.10.38	
47	0.10.17.16	
48	UNI 6592 Ø16	
49	0.60.62.03	
50	5.13.81.00	
51	0.60.63.06	
52	5.17.10.39	
53	5.06.30.36	
54	Switch	303390
55	5.18.25.04	
56	UNI 5933 M8x25	
57	5.12.40.60	
58	0.60.62.04	
59	3.27.73.97	
60	Free wheel	303475

Pos.	Description	Part #
61	5.13.07.46	
62	5.00.15.62	
63	5.08.10.07	
64	5.14.20.58	
65	5.10.05.05	
66	5.12.06.61	
67	UNI 5588 M4	
68	5.12.20.17	
69	5.12.40.30	
70	0.06.40.02	
71	0.71.15.28	
72	0.14.00.99	
73	0.08.02.60	
74	UNI 6592 Ø16	
75	5.06.10.38	

Pos.	Description	Part #
76	5.06.60.16	
77	Microswitch	303434
78	5.18.28.42	
79	DIN 7500 M5x10	
80	Microswitch button	303462
81	5.14.20.59	
82	5.18.25.23	
83	UNI 7687 M4x10	
84	0.10.61.20	
85	UNI 6592 Ø20	
86	Drive wheel	303474
87	0.15.51.49	
88	5.13.07.95	
89	UNI 5589 M12	
90	0.60.62.04	
91	UNI 6954 P7x16	
92	Pilot light	303425
93	Gear group	303468
94	0.15.01.39	
95	0.58.62.00	
96	5.02.41.22	
97	Hydraulic group	303464
98	0.60.60.07	
99	5.12.40.54	
100	5.04.29.23	
101	Gear group	303435
102	0.73.12.12	
103	0.12.40.26	
104	Gear group	303432
105	5.85.00.06	
106	5.15.45.01	
107	UNI 5588 M4	
108	0.18.10.21	
109	Elec. speed regulator	303465
110	5.18.28.23	
111	0.18.10.18	
112	5.18.28.43	
113	Fan with magnetic ring	303473
114	UNI 5931 M6x20	
115	5.18.25.25	
116	UNI7687 M5x35	
117	Motor	303472
118	UNI 5931 M6x40	
119	0.81.60.05	
120	5.06.10.41	



Pos.	Description	Part #
121	7.01.31.58	
122	0.24.14.43	
123	0.40.05.13	
124	0.80.26.11	
125	5.13.80.99	
126	UNI 5588 M10	
127	UNI 5927 M8x10	
128	UNI 5927 M10x45	
129	5.13.10.13	
130	UNI6592 Ø5	
131	0.32.06.12	
132	Blade protection	303467
133	0.12.33.15	
134	1.85.58.03	
135	5.18.16.88	
136	DIN 7500 M5x10	
137	DIN 7500 M5x16	
138	5.15.25.96	
139	7.13.05.67	
140	UNI 5931 M5x16	
141	Electronic card	303389
142	Handle group	303463
143	0.80.60.29	
144	5.12.40.91	
145	0.24.13.67	
146	5.87.36.06	
147	DIN 7500 M5x15	
148	5.15.41.03	
149	UNI 5927 M6x10	
150	0.41.06.34	
151	0.24.13.66	
152	1.85.58.05	
153	Ball bearing	7x19x 6 2RS
154	5.18.18.71	
155	UNI 7987 M6x10	
156	5.13.07.47	
157	UNI 5931 M8x30	
158	5.18.18.72	
159	5.18.18.32	
160	Hand lever	303466
161	0.12.40.29	
162	0.06.30.25	
163	5.10.00.69	
164	5.13.09.42	
165	0.12.40.27	

Pos.	Description	Part #
166	UNI 5931 M6x25	
167	0.60.06.26	
168	5.13.09.43	
169	5.10.00.70	
170	Ball bearing	7x19x 6 2RS
171	5.12.06.38	
172	UNI 1751 Ø6	
173	UNI 5721 M6	
174	0.24.14.42	
175	UNI 5732 M10x40	
176	0.24.14.42	
177	UNI 5721 M6	
178	UNI 1751 Ø6	
179	5.12.06.38	
180	5.13.38.28	
181	5.13.38.29	
182	7.82.01.54	
183	5.14.00.71	
184	5.14.21.14	
185	5.13.80.98	

Please contact factory for current prices.

ORDERING INFORMATION

Parts are available for direct purchase from Dake or through a distributor. When placing a parts order, you will need to provide the part number, name of part, and model number. All parts shipped F.O.B. Factory in Grand Haven, MI.