

Operator's Manual and Part's List

Model J-10 & JH-10 Dake/Johnson Horizontal Bandsaw



DAKE Division of JSJ
724 Robbins Road
Grand Haven, MI 49417
Phone: 1-800-937-3253 616-842-7110
Fax: 1-800-846-3253 616-842-0859
E-mail: customerservice@dakecorp.com
technicalservice@dakecorp.com
Web: www.dakecorp.com

FOREWORD

This manual has been prepared to acquaint you with the operation, maintenance, and serviceable components of your Dake/Johnson machine. We urge that you read it carefully before operating your machine. Please refer to the pertinent sections when contacting the factory regarding parts, schematics...or when you have other questions.

As Dake's policy is one of continuous development for each range of machine, the contents of this manual, though completely up to date when issued, are subject to change without notice.

For your information and future reference, pertinent data concerning your machine may be inserted in the space provided below.

Machine Model _____
 Serial Number _____
 Date Received _____
 Voltage _____
 Phase _____ Cycle _____ Motor H.P. _____

Please give the machine model and serial number in correspondence, and include the parts numbers on parts orders to speed the filling of your requirements and to minimize your inconvenience.

FACTORY: **DAKE Division of JSJ**
 724 Robbins Road
 Grand Haven, MI 49417
 Phone: 1-800-937-3253 616-842-7110
 Fax: 1-800-846-3253 616-842-0859
 E-mail: customerservice@dakecorp.com
 technicalservice@dakecorp.com
 Web: www.dakecorp.com

NOTE: Use only genuine Dake/Johnson replacement parts and optional equipment. Use of substitutes or imitations may cause damage to the machine, void the warranty, and may cause injury.

CONTENTS

GENERAL

Basic Machine Data	4
Specifications	4
Machine Installation	4
Safety Information.....	5-6
Electrical Diagrams	7-9
Machine Features	10

SECTION 1

OPERATION

Controls and Operation	11
Standard Drive	12
Blade Selection	13
Blade Removal/Installation	13-14
Blade Guide Adjustment	14-15
Balance Spring Adjustment	15
Feed Cylinder Bleeding	15

SECTION 2

MAINTENANCE

Lubrication	16
Sawing Problems and Solutions	17

SECTION 3

ASSEMBLIES & PARTS LISTS

Machine Assembly (Front View)	18-19
Machine Assembly (Top View)	20
Gear Box Assembly	21
Hydraulic Assembly	22-23
Guide Arm Assembly	24
Vise Unit	25

BASIC MACHINE DATA

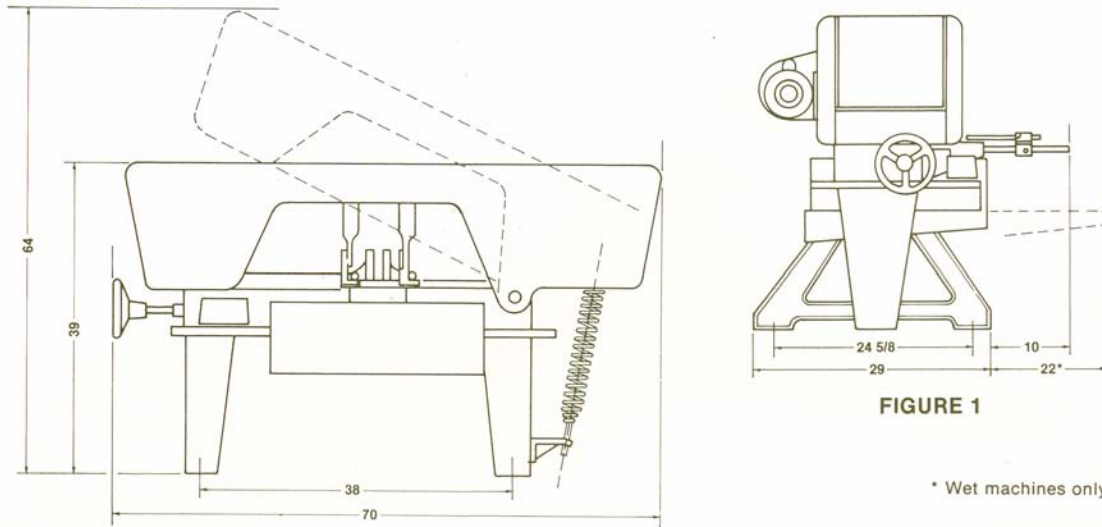

SPECIFICATIONS

Capacity.....10" (25cm) rounds, 18" (46cm) flats	Floor Space 29" (74cm) x 70" (178cm)
Blade Size (Part Numbers: 75958 (3/4") OR 75957 (1"))	Height, Closed* 39" (99cm)
J-10 3/4" (2cm) x 137" (348cm)	Height, Open* 64" (163cm)
JH-10..... 1" (3cm) x 137" (348cm)	Floor to Bed* 23 3/4" (60cm)
Blade Speeds	Net Weight
.....50, 90, 160 and 270 fpm	J-10 Dry 812 lbs (368 kgs)
.....15, 29, 49 and 82 mpm	J-10 Wet 845 lbs (383 kgs)
Bed Work Area. 11" (28cm) x 18" (46cm)	JH-10 Dry 817 lbs (371 kgs)
Vise Size 5" (13cm) x 11" (28cm)	JH-10 Wet 850 lbs (386 kgs)
Drive Motor	Gross Weight
J-10 1 hp (.75kw)	J-10 Dry 896 lbs (406 kgs)
JH-10 1 hp (.75kw)	J-10 Wet 929 lbs (409 kgs)
Electrical System, specify110/230V, 1 PH, 60 Hz	JH-10 Dry 901 lbs (409 kgs)
.....208/230/460V, 3 PH, 60 Hz	JH-10 Wet934 lbs (424 kgs)
Coolant Capacity 3 gallons	Water-soluble only – do not use oil.

INSTALLATION

UNCRATING : Remove crating carefully. For ease in handling do not remove from skid until machine has been moved to its approximate location.

CAUTION: BE SURE ELECTRICAL CHARACTERISTICS OF MOTOR AND SWITCH CORRESPOND WITH ELECTRICAL POWER SUPPLY.

!!!ATTENTION!!! DO NOT ATTEMPT TO RUN THIS SAW UNTIL THE BLADE ALIGNMENT HAS BEEN CHECK AS PER THE OWNER'S MANUAL AND THE BLADE HAS BEEN PROPERLY RETENSIONED.

LEVELING: Position machine reasonably level, shim under legs if necessary. Wet machines should be more carefully leveled to be certain that the coolant intake remains submerged.

CONNECT INCOMING POWER TO THE STARTER PER APPLICABLE DIAGRAM, AND IN ACCORDANCE WITH ALL LOCAL CODES.

SAFETY INFORMATION

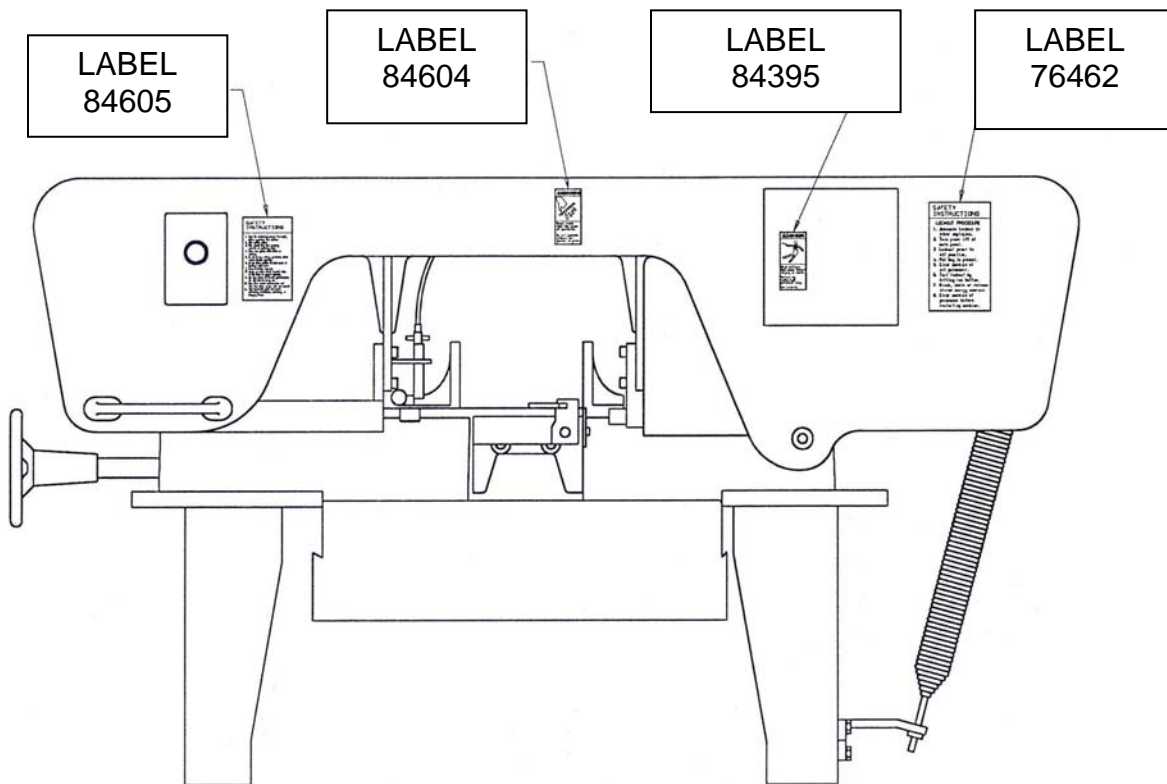

LABEL 84605 – SAFETY INSTRUCTIONS



SAFETY

This is the safety alert symbol. When you see this symbol on your saw, be alert to the potential for personal injury.

Follow recommended precautions and safe operating practices. Carefully read all safety messages in these instructions and on your saw safety signs. Keep safety labels in good condition. Replace missing or damaged safety labels.

SAFETY INSTRUCTIONS

1. Read the instruction manual thoroughly before operating this machine.
2. Wear safety glasses.
3. Wear gloves only when handling material or replacing blade.
4. Never wear gloves while blade is rotating.
5. Do not perform cutting operations which exceed machine capacity.
6. Do not force machine to stall blade or breakage might occur.
7. Clamp workpiece securely.
8. Always use stock stands on both sides of saw blade to support material.
9. Use blade with the correct specification for the material being cut.
10. Keep floor around machine clean and free from chips, scraps, oil, and coolant.
11. Turn electrical power off before performing maintenance, servicing, or changing blades.

LABEL 76462 – SAFETY INSTRUCTIONS

SAFETY INSTRUCTIONS

LOCKOUT PROCEDURE

1. Announce lockout to other employees.
2. Turn power off at main panel.
3. Lockout power in off position.
4. Put key in pocket.
5. Clear machine of all personnel.
6. Test lockout by hitting run button.
7. Block, chain or release stored energy sources.
8. Clear machine of personnel before restarting machine.

LABEL 84395 – DANGER LABEL

⚠ DANGER

**High voltage.
Can cause severe injury or death.**

Service by authorized personnel only.

Use lockout.



⚠ PELIGRO ⚠

**Alta tensión.
Puede provocar lesiones severas o la muerte.**

Para reparaciones, emplee personal autorizado solamente.

Use cierre eléctrico.

LABEL 84604 – WARNING

⚠ WARNING



Never reach into the point of operation.

Do not operate without all guards in place.

Follow recommended precautions and safe operating practices. Carefully read all safety messages in these instructions and on your saw safety signs. Keep safety labels in good condition. Replace missing or damaged safety labels.

**SAFETY**

This is the safety alert symbol. When you see this symbol on your saw, be alert to the potential for personal injury.

ELECTRICAL CONTROL DIAGRAMS

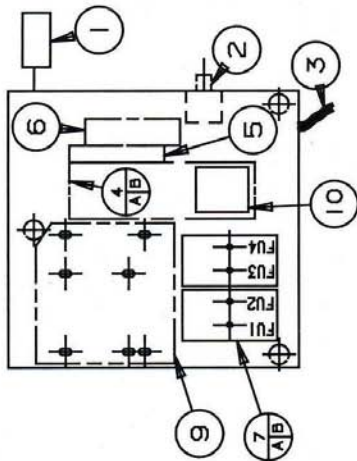

ITEM	PART NO.	DESCRIPTION	QTY.
8		NOT USED AT THIS TIME	0
9	79998 72642	TRANSFORMER FOR 115/230 VOLT SINGLE PHASE TRANSFORMER FOR 230/460 VOLT THREE PHASE	1 1
10		HEATER PACK (3 HEATERS IN A PACK)	1
	72645	115V FOR J1001, J10V1, JH1001, JH10V1, SET 1/2 WAY BETWEEN C & D	
	71418	230V 1 PHASE FOR J1001, J10V1, JH1001, JH10V1, SET AT C-	
	77054	230V 3 PHASE FOR J1003, J10V3, JH1003, JH10V3, SET AT B-	
	72636	460V 3 PHASE FOR J1003, J10V3, JH1003, JH10V3, SET 1/2 WAY BETWEEN C & D.	

NOTE: WHEN CONVERTING A FIELD SAW FROM 3/4 HP TO 1 HP ADJUST THE HEATER PACK TO THE VALUE INDICATED IN THE CHART ABOVE ON ALL MODELS EXCEPT FOR J1003 AND J10V3 ON 230 VOLT 3 PHASE. FOR THE TWO SAWS THAT OPERATE ON 230V 3 PHASE, J1003, AND J10V3 THE HEATER PACK MUST BE REPLACED WITH DAKE PART NUMBER 72635 AND SET 1/2 WAY BETWEEN B & C.

ITEM	PART NO.	DESCRIPTION	QTY.
1	716467	LIMIT SWITCH ASSEMBLY	1
2	716468	TOGGLE SWITCH ASSEMBLY	1
3	79935 or 79960	1PH or 3PH MOTOR SEALTITE ASSEMBLY	1
4A	72762	STARTER	1
4B	72764	COIL FOR STARTER	1
5	71417	2 - N.O. AUX. CONTACTS	1
6	72763	START/STOP P.B. MODULE	1
7A	72632	FUSE BLOCK	2
7B	FUSES FUI - FUA AS BELOW		
FUI	72633	STARTER CONTROL CIRCUIT FUSE	1
FU2	72634	LUBE PUMP CIRCUIT FUSE	1
FU3, FUA	300185	TRANSFORMER PRIMARY FUSE	2
	77523	FOR 115V ON J1001, JH1001, J10V1, JH10V1	
		FOR 230V ON J1001, J1003, J10V1, JH10V1, J10V3, JH10V3	
	76894	FOR 460V ON J1003, J10V3, JH1003, JH10V3	

THE NUMBERS LISTED BELOW ARE THE "GRAY" ELECTRICAL BOX ON THE SIDE OF THE SAW AND WILL CONTAIN SOME OR ALL OF THE FOLLOWING: 2, 4A, 5, 6, 7A/B, 9, & 10.
NOTE: ITEMS FU2 AND 2 ARE ON MET SAWS ONLY.

DPN	SAW TYPE	MODEL	DPN	SAW TYPE	MODEL
716663	J1001-1	985011-1	716671	JH1001-1	985015-1
716664	J1001-2	985011-2	716672	JH1001-2	985015-2
716665	J1003-2	985012-2	716673	JH1003-2	985016-2
716666	J1003-4	985012-4	716674	JH1003-4	985016-4
716667	J10V1-1	985013-1	716675	JH10V1-1	985017-1
716668	J10V1-2	985013-2	716676	JH10V1-2	985017-2
716669	J10V3-2	985014-2	716677	JH10V3-2	985018-2
716670	J10V3-4	985014-4	716678	JH10V3-4	985018-4

FROM 72631S2

SINGLE PHASE ELECTRICAL DIAGRAM

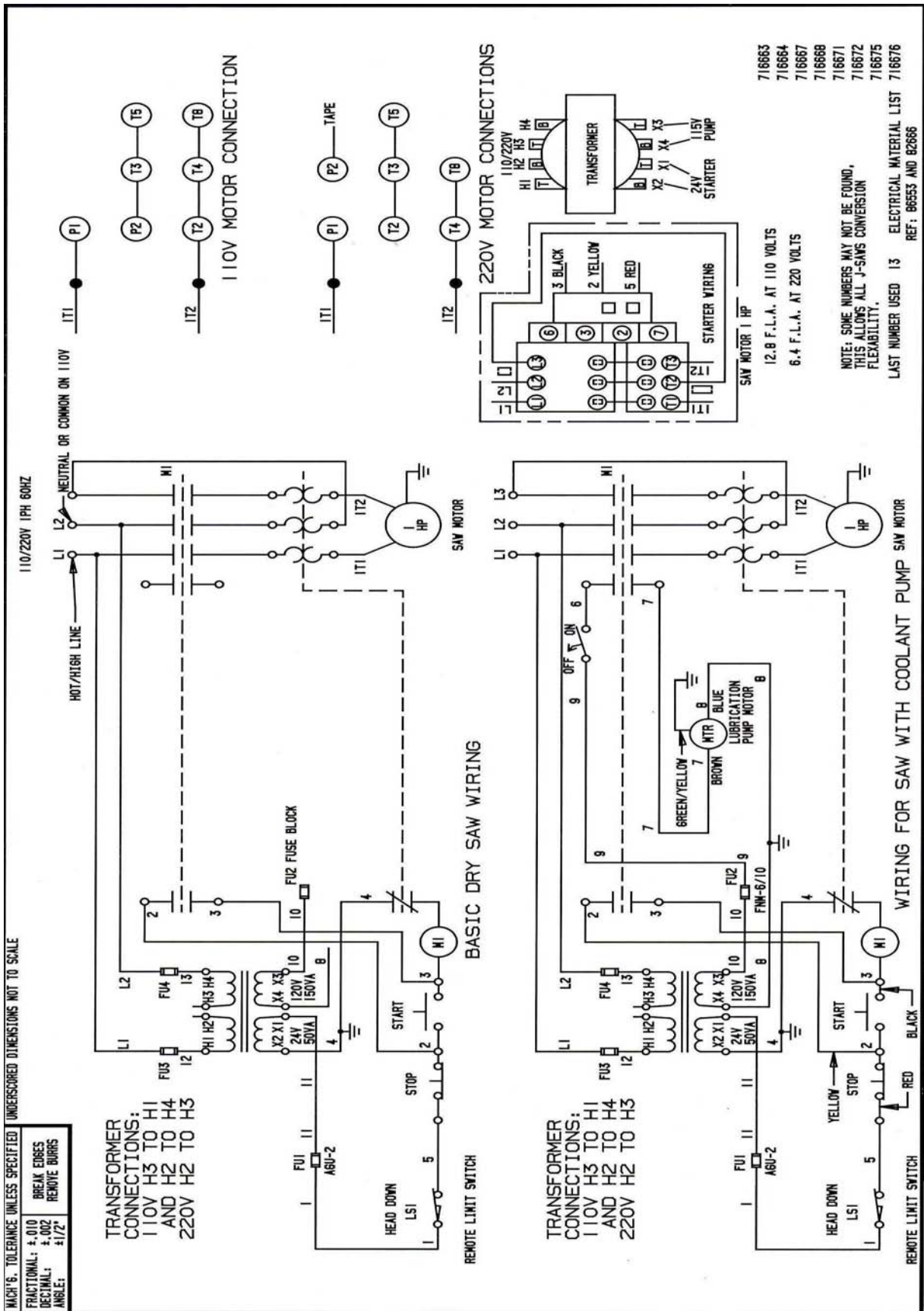

THREE PHASE ELECTRICAL DIAGRAM

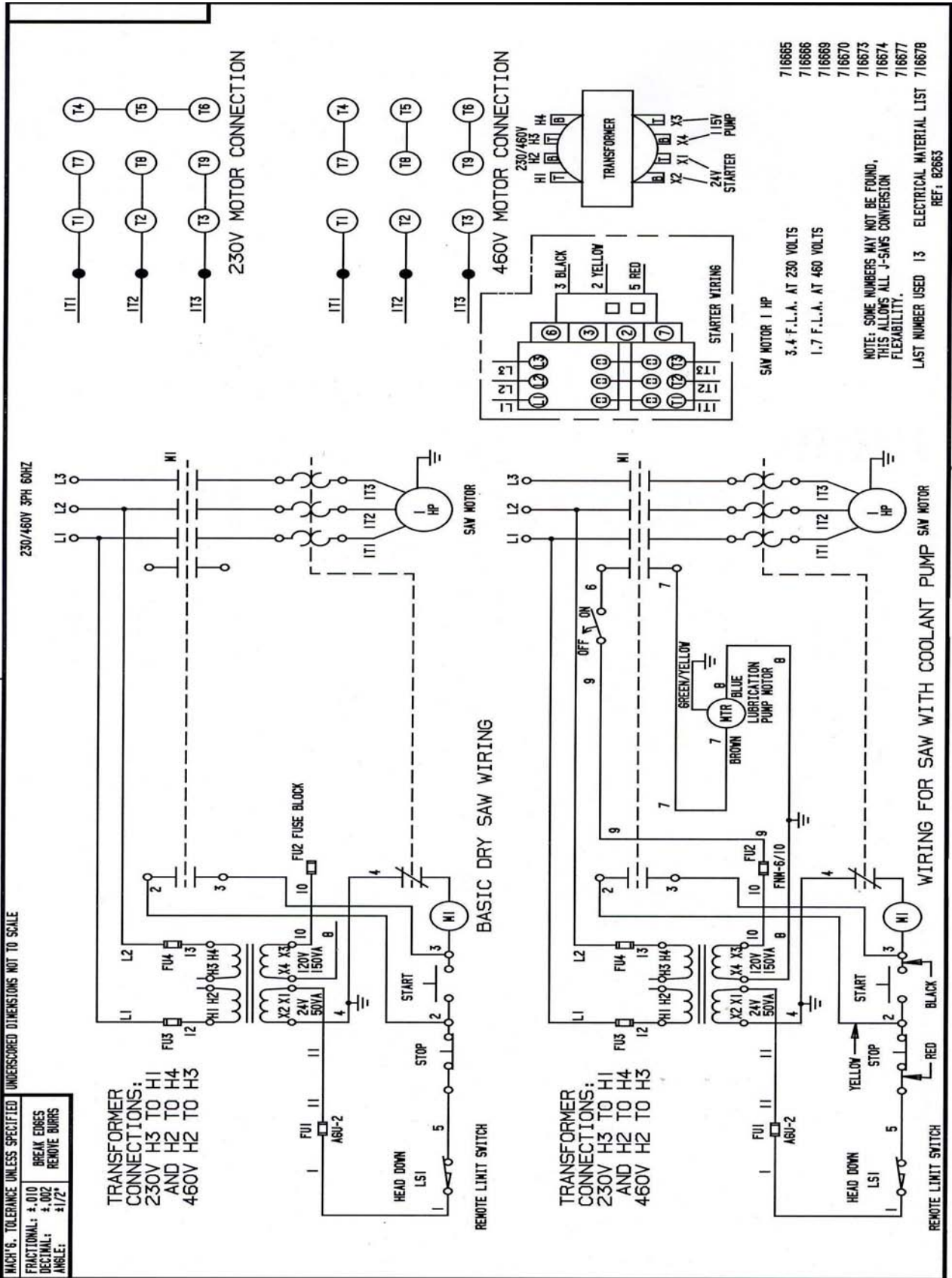

MACHINE FEATURES

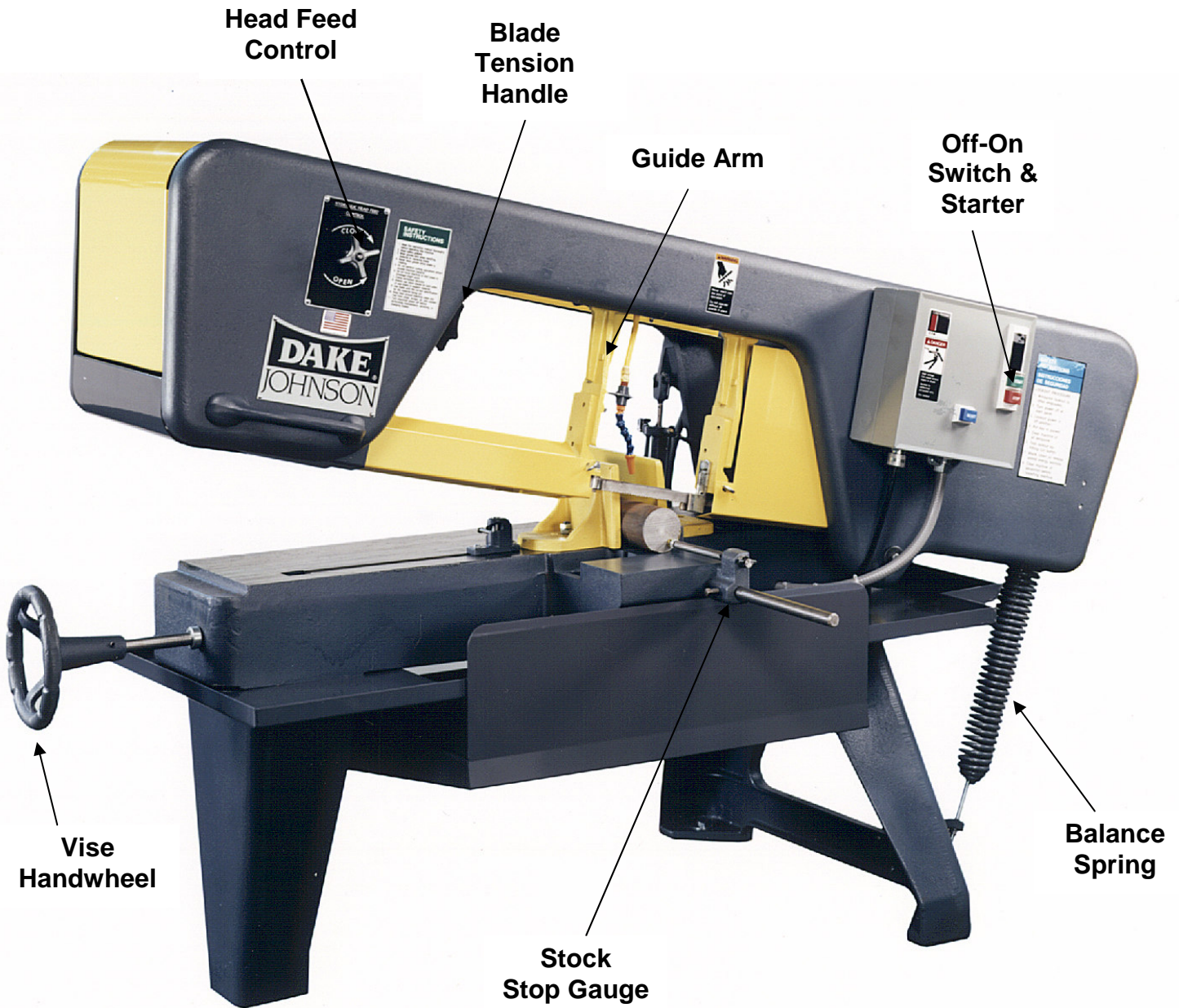

SECTION 1

OPERATION

OFF/ON SWITCH

All J-saw machines are equipped with a manual starter with low voltage, dropout protection and a limit switch. When the machine frame reaches the end of its down travel it contacts the limit switch, turning off the machine.

HYDRAULIC CONTROL

The hydraulic control cylinder mounted on the rear of the machine is operated by a control valve mounted on the front of the machine head. To close valve, turn the control to the right. When the valve is completely closed, the frame will remain stationary at the desired position. To open valve, turn control to the left. Opening of the valve will control the speed of descent of frame (or head) and does not control frame weight. This control is mainly used in cutting pipe or thin-walled tubing, structurals, etc., to prevent plunging of the saw blade.

WISE

The vise can be positioned straight for a 90° cut or at any angle to 45°. The vise swivel jaw adjusts automatically to any position of the stationary jaw.

WISE QUICK-RELEASE

Consists of the vise half-nut, vise lift, lift handle and a sliding hold-down block to which the swivel jaw is attached. Move the vise lift handle toward front of the machine to disengage the vise nut from the vise screw; this allows the swivel jaw to be moved freely. Move the lift handle towards the rear of the vise to engage the vise nut when clamping.

WISE HANDWHEEL

Used to open and close the vise jaws...vise nut must be fully engaged. Turn handwheel counterclockwise to open the vise, clockwise to close the vise.

BLADE TENSION HANDLE

Turn the screw handle clockwise as tight as possible. Check every eight operating hours and retighten to compensate for possible stretching of blades. Consult your blade manufacturer for the proper PSI tension.

GUIDE ARMS

Loosen the handle on the left guide arm to slide arm along the top of the frame. Guide arms should be set as close as possible to the work, without interfering.

STOCK STOP GAUGE

Consists of a stock stop assembly and a mounting bar installed in the tip-off block on front of the machine. The stop assembly can be moved along the bar to indicate correct length for duplicate cuts. Stock stop rod has a cap screw in the end for making fine adjustments. Turn rod to extended position (rotated to the right) when measuring stock, and retract the rod (rotate to left) when cutting.

OPERATING INSTRUCTIONS

1. Raise frame and close feed cylinder valve to hold frame in elevated position.
2. Loosen the vise nut and open the vise. Place work in vise and slide the vise swivel jaw against the work piece. Engage the vise nut and tighten the vise screw to clamp the work securely.
3. Slowly open feed cylinder valve and lower the frame until the blade almost touches the work. **CAUTION: IF BLADE SHOULD REST UPON THE WORK BEFORE MOTOR IS STARED THE BLADE TEETH CAN BE DAMAGED- IF BLADE IS DROPPED ONTO THE WORK THE BLADE MIGHT BREAK. MAKE SURE BLADE IS PROPERLY BROKEN IN PRIOR TO CUTTING.**
4. Move the adjustable guide arm as close as possible to the work to provide maximum blade rigidity.
5. Check the blade tension. Consult blade manufacturer for proper PSI tension.
6. Turn coolant valve on (wet machines only). **CAUTION: DO NOT OPERATE MACHINE WITHOUT SUFFICIENT COOLANT IN TANK. COOLANT MUST BE WATER-SOLUBLE DO NOT USE OIL.**
7. Check blade speed for material you are cutting. Refer to blade manufacturer for proper speeds for the material you are cutting.
8. To change blade speed, loosen thumbscrew on right end of machine and raise the pulley guard. Move drive belt to proper grooves in both pulleys for desired blade speed, (see fig. 3). Replace guard.

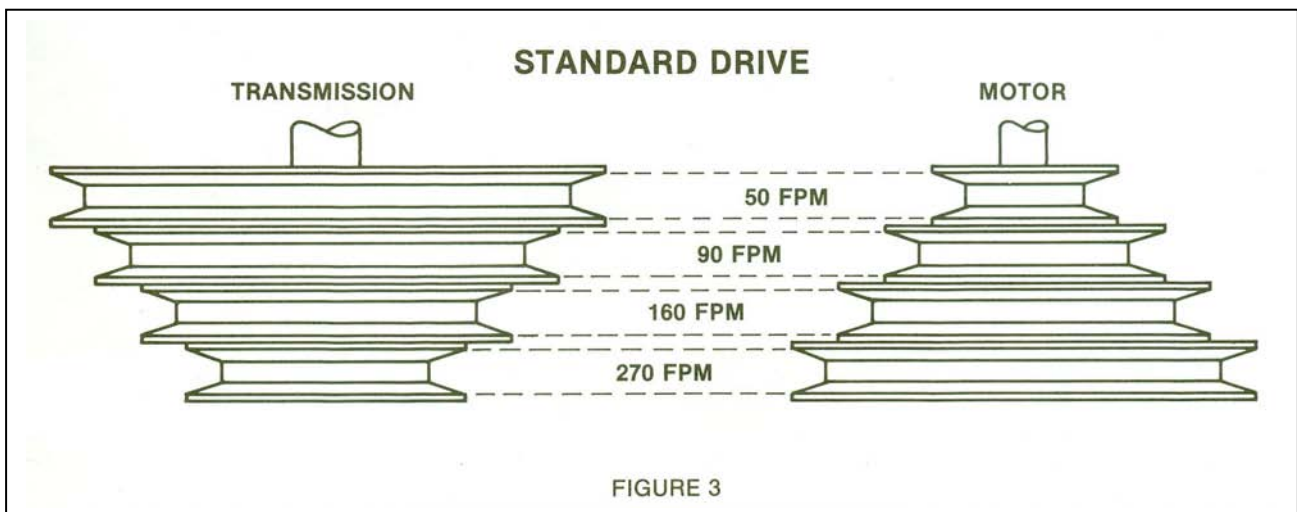

9. Start motor.
10. Open feed cylinder valve to the proper setting. "Proper" setting depends upon type of material, hardness and thickness of stock and desired accuracy and finish. Soft materials require less feed than hard materials. Thin cross-sections require less feed than solid cross-sections. Generally, reduced feed pressure will result in a straighter more accurate cut.

BLADE SELECTION

Saw blades should be selected by choosing the blade that will give the best results at the lowest cost. Type of material and the speed at which it must be sawed determine the choice. Listed below are general factors affecting blade selection.

1. Blade Type.

(a) Carbon Steel – Can be used to cut all types of ferrous, non-ferrous and composition materials except alloys containing high percentage of chrome and nickel. Limiting factor: low resistance to heat.

(b) Bi-Metal – Designed for cutting ferrous metals in production cut-off applications. Developed to saw high alloy materials that cannot be cut economically by other means. Can be operated at higher speeds and greater feed pressures than carbon steel blades.

2. Tooth Style.

(a) Standard – Zero degree rake angle and full round gullets. Best suited for cutting ferrous and non-ferrous materials.

(b) Skip Tooth – Basically the same as standard except for more widely spaced teeth. Provides added chip room when cutting non-ferrous materials.

(c) Hook Tooth – Similar to skip tooth except teeth have positive rake. Effective in sawing non-ferrous metals and large ferrous sections when heavy feed pressures are required. Fast cutting.

3. Tooth Spacing.

Tooth spacing is determined by hardness of material and/or the cross-section. The harder the material, the more teeth per inch. Thin cross-sections require more teeth to avoid straddle. Rule: at least 3 teeth in contact with work.

4. Tooth Set.

(a) Raker – Most widely used. Consists of a repeated pattern of one tooth set left, one right and one tooth straight. Recommended for production cutting where material is of uniform size, shape and type.

(b) Wavy – Has groups of teeth set alternately to the left and to the right forming a wave-like pattern. Used for cutting thin stock or where the work varies such as in pipe, angles, channels and extrusions.

BLADE REMOVAL

1. Raise frame a few inches above bed and close feed cylinder valve to hold frame up.
2. Remove necessary guarding and blade cleaning brushes.
3. Turn blade tension screw counterclockwise and pull idle wheel toward center of machine.
4. Push blade down out of blade guides and remove blade from machine.

BLADE INSTALLATION

1. Raise frame a few inches above bed and close feed cylinder valve to hold frame up.
2. Remove necessary guards and blade cleaning brushes.
3. Turn blade tension screw counterclockwise and pull idle wheel toward center of machine.
4. Grasp blade in center forming two loops. From rear of machine place blade loops under wheels and rest the rear portion on right front blade guard. CAUTION: BE SURE TO WEAR GLOVES WHEN HANDLING BLADES.
5. Push blade up into blade guides. CAUTION: BE AWARE OF HYDRAULIC & COOLANT LINES.
6. Fit blade up against flanges of the idle and drive wheels and tighten tension screw enough to hold blade in place. Depress side of blade near rear blade guard to hold blade on wheels while tightening tension screw.
7. Check to see that the blade is positioned correctly and tighten screw. Consult blade manufacturer for proper PSI tension.
8. Install blade cleaning brushes and guards that were removed earlier.

BLADE TRACKING ADJUSTMENT

Saw blade should track on each wheel with the back of blade up to, but not riding on, the wheel flange. Adjust as follows:

1. Idle Wheel.

Open top cover on left end of machine to gain access to idle wheel. Idle wheel is mounted on a slide block, which contains the blade height adjustment screws. To raise the blade, loosen the two screws toward center of machine (**A, Fig. 4**) one-half turn and tighten the other two screws (**B**) one-half turn. Be sure tension screw (**C**) is properly tightened. Reverse procedure to lower blade. Care must be taken not to over adjust. Check by running machine after each adjustment.

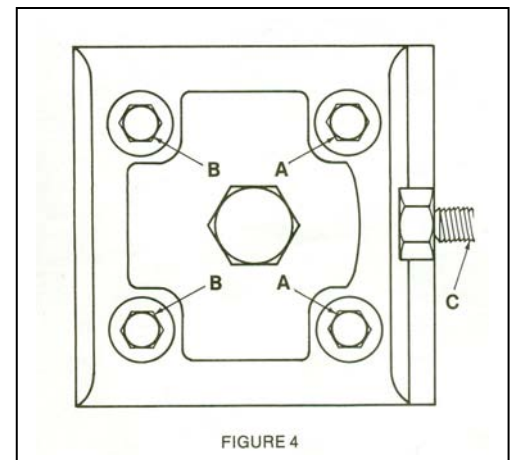

FIGURE 4

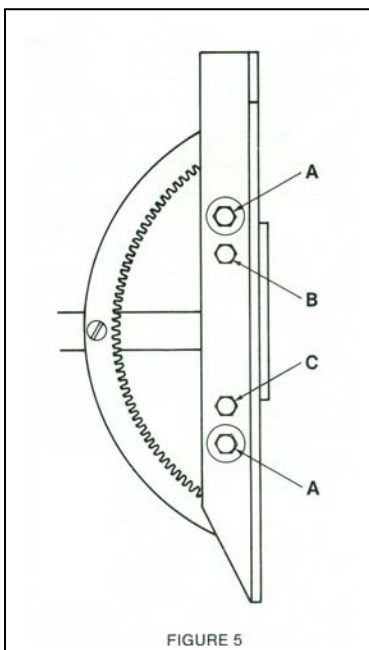

FIGURE 5

2. Drive Wheel.

(a) To raise the blade, loosen two cap screws (**A, Fig. 5**) and tighten screws (**B** and **C**). All four screws must be turned equally and in small increments (about $\frac{1}{2}$ turn) to avoid over-adjustment; check by running machine after each adjustment.

(b) To lower blade, reverse above procedure – loosen screws (**B** and **C**) and tighten screw (**A**).

BLADE GUIDE ADJUSTMENT

NOTE: *The following instructions are for one guide arm; procedure is same for both. Left hand guide arm is shown in Figure 6.*

1. Loosen nut (A, Fig. 6) and turn eccentric axle (B) until there is no light gap between rollers and blade...do not pinch the blade. Tighten nut (A).
2. Vertical and radial adjustment is provided by the clearance in the guide mounting holes (C, Fig. 6). This allows squaring of the blade to the bed, and holding the blade in the natural blade line.
3. Proper guide adjustment may require adding or removing washer (shims) (D, Fig. 6) for correct bearing height (E, fig. 6)

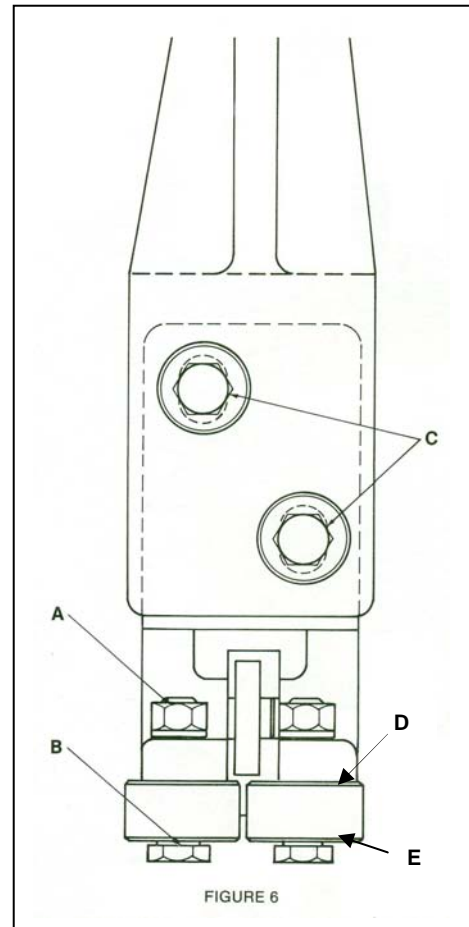

FRAME BALANCE SPRING ADJUSTMENT

To check for proper balance spring adjustment, lift frame at eh handle with an extension type scale (fish scale). Frame should weigh 12-15 pounds; if no, adjust by turning nut on the tension screw at bottom of spring.

FEED CYLINDER BLEEDING

Air trapped in the hydraulic cylinder can cause the down feed of the machine head to be erratic or “bouncy”. Before taking corrective steps observe CAUTION.

CAUTION: UNDER NO CIRCUMSTANCES SHOULD THE HYDRAULIC TUBING CONNECTIONS BE LOOSENED OR DISCONNECTED WITH THE MACHINE HEAD IN THE UP POSITION.

Bleed the hydraulic cylinder circuit as follows:

1. Place a long neck funnel in the oil cup (diameter of funnel neck must be almost the same size of the fill cup).
2. Pour oil into the funnel. *Make sure there is a sufficient amount of oil in the funnel so that air does not get drawn into cylinder.
3. With head feed valve open, raise and lower head about four times.
4. Pour more oil into the funnel.
5. Close head feed valve.
6. Raise head.
7. Open feed valve and lower head.
8. Repeat 5,6 & 7 several times.
9. Remove funnel.

MAINTENANCE

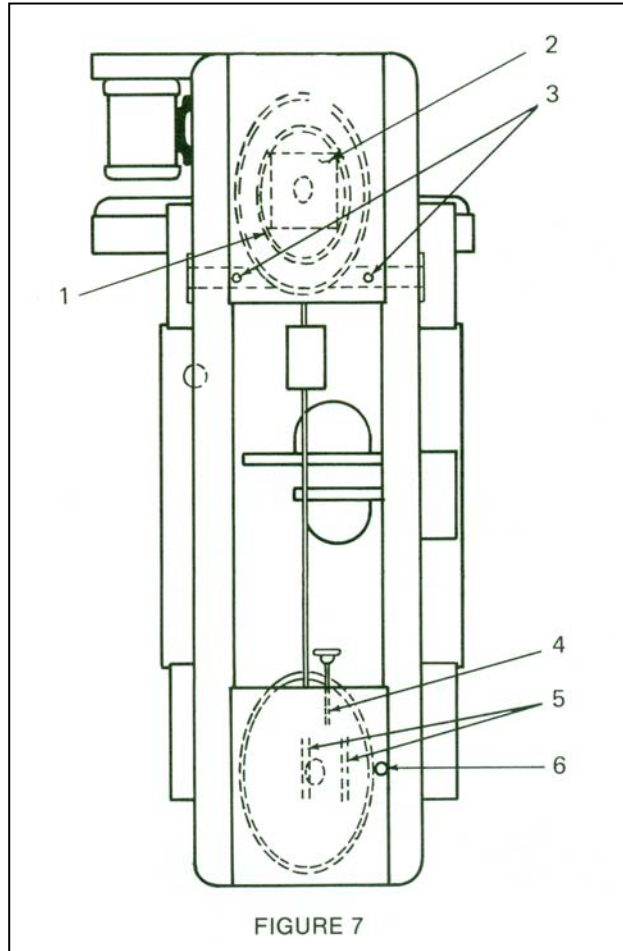

LUBRICATION

Lube Point	Description	Interval	Lubricant	Instructions
1	Drive wheel ring gear	6 months	D	Clean thoroughly before lubricating.
2	Gear box	Maintain level	B	Maintain level at 2 to 3 ounces. Drain and refill yearly. Capacity 3 ounces.
3	Pivot bar (2 fittings)	Monthly	C	Use grease gun.
4	Tension screw	6 months	C	Clean threads before lubricating.
5	Idle wheel slide ways	6 months	C	Clean thoroughly before lubricating.
6	Feed cylinder	Maintain level	A	Maintain level at top of oil cup.

RECOMMENDED LUBRICANTS

- A** – Mobil DTE 24 or 26 oil. Viscosity range 310SSU @ 100°F.
- B** – Gear oil 80/90. Mobil SHC634 synthetic gear lube.
- C** – General purpose grease. Viscosity range NLGI-2.
- D** – Open gear lubricant.

SAWING PROBLEMS & SOLUTIONS

Blade not cutting straight

Blade breaking/teeth stripping

Premature blade dulling

Back of blade swaging over

Pieces breaking away from back of blade

•			•		Improper blade tensions	Adjust tension screw
•	•		•		Excessive feed rate/cutting pressure	Turn cylinder control knob to decrease head descent speed and/or move slide weight to right
•			•		Guide arms too far from work or cutting pressure all on one guide	Move guide arm
•	•				Improper contact of cleaning brushes with blade	Clean brushes and adjust holder; replace brushes if worn out
•					Damaged or worn blade	Replace blade
•	•				Material insecurely held in vise	Adjust vise handwheel
•	•				Improper guide roller adjustment	Readjust rollers
•					Blade guides improperly adjusted	Readjust guides
	•				Head approaching work too fast	Turn cylinder control knob to decrease head descent speed
	•	•			Blade too coarse	Install proper blade
	•				Excessive blade tension	Readjust blade tension
		•			Insufficient feed pressure	Turn cylinder head control knob to increase head descent speed and/or move slide weight to left
			•		Blade riding up on wheel flanges	Re-adjust blade tracking
				•	Blade tracking too high on wheels	Adjust drive and idle wheels for proper blade tracking

ASSEMBLIES AND PARTS LIST

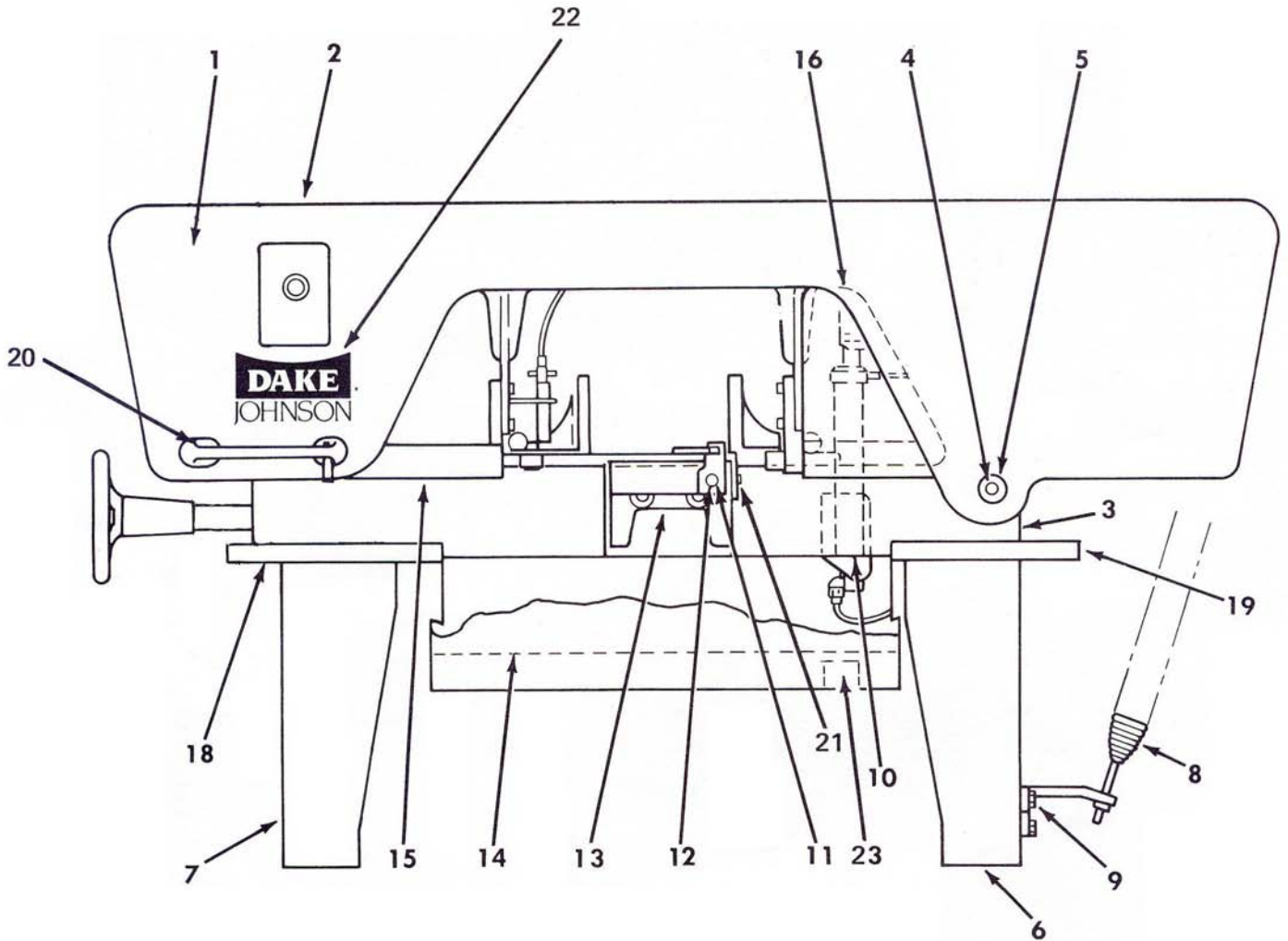

MACHINE ASSEMBLY, Front View

ITEM	PART NO.	DESCRIPTION	QTY
1	10002-01	Front Frame	1
2	10003-01	Rear Frame	1
3	10001-00	Bed	1
4	10066-00	Pivot Bar	1
5	13010-08	Shaft Locking Collar	2
6	10004-02	Right Leg	1
7	10005-02	Left Leg	1
8	10070-00	Balance Spring - includes carriage bolt and nut	1
9	10100-01	Spring Perch	1
10	10101-00	Outboard Bearing Casting – (uses 3/8” bolt – lockwasher - nut)	1
11	5527-00	Stock Stop Assembly	1
11A	5027-00	Holder Casting	1
11B	5213-00	Rod	1
11C	5028-00	Spring	1
11D	5200-00	Handle	1
12	5027-01	Stock Stop Mounting Bar	1
13	10006-01	Tip-off Block	1
14	10269-00A	Coolant Drawer Pan	1
15	300405A	Left Hand Blade Guard	1
16	300404A	Right Hand Blade Guard	1
17			
18	10268-07A	Left Leg Pan	1
19	10268-05A	Right Leg Pan	1
20	10093-00	Frame Handle	1
21	10229-00	Brush holder Guard	1
22	72295	Dake/Johnson Name Plate	1
23	71541	Submersible Coolant Pump – Electric 110 volt	1

PARTS NOT ILLUSTRATED

PART NO.	DESCRIPTION	QTY
10079-05	Motor, 230/460 volt, 60 Hz, 3 phase – 1 H.P.	1
10079-07	Motor, 110/230 volt, 60 Hz, 1 phase – 1 H.P.	1
10042-10	Motor Pulley – 5/8” Bore	1
10077-10	Drive Belt	1
10223-10A	Pulley Guard	1
5107-00	Motor Hanger Base	1
5106-02	Frame Hanger Motor Base	1
5106-03	Motor Mounting Pin	1
300403A	Frame Covers (Left and Right Hand Sides)	2
300804	Knob for Frame cover 300403A	4
10230-10A	Rear Frame Blade Guard	1
10271-00A	Drive Wheel Drip Pan	1
10287-00	Strap, Wheel Pan	1
10286-00	Bar, Wheel Pan	1
70295	Thumb Screw – Drive Wheel Drip Pan	2
10209-01	Spring Bracket Top	1
10126-13A	Lower Left Front Cover	1
10091-10	Frame Rest	1
300407A	Drive Wheel Cover	1
300408A	Idle Wheel Cover	1
300409A	Drive & Idle Wheel Spoke Guards	2
300246	Wire Ties	12

MACHINE ASSEMBLY, Top View

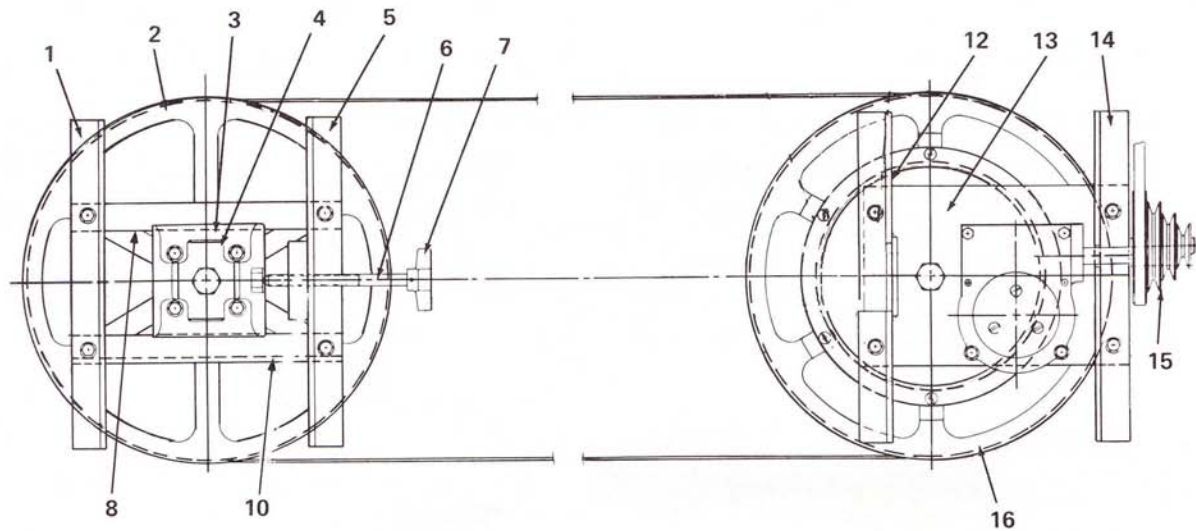

ITEM	PART NO.	DESCRIPTION	QTY
1	10064-09	Idle Wheel and Frame Mounting Bracket (Outboard)	1
2	10510-02	Idle Wheel Assembly (J-10)	1
	10010-02	Idle Wheel Only (J-10)	1
	10510-04	Idle Wheel Assembly (JH-10)	1
	13035-01	Idle Wheel Only (JH-10)	1
	10062-00	Wheel Axle (J-10 & JH-10)	1
	10134-01	Bearing Cup (J-10 & JH-10)	2
	10134-02	Bearing Cone (J-10 & JH-10)	2
	10135-00	Dust Collar (J-10 & JH-10)	2
	10136-00	Snap Ring (J-10 & JH-10)	1
3 & 4	5011-01	Slide & Rocker Block Assembly	1
5	10064-08	Idle Wheel and Frame Mounting Bracket (Inboard)	1
6 & 7	10125-01	Tension Screw Assembly	1
8	10210-00	Slideway – Top	2
10	10067-00	Slideway – Bottom	1
12	10064-10	Drive Wheel and Frame Mounting Bracket (Inboard)	1
13	10063-00	Gear Box Mounting Plate	1
14	10064-06	Drive Wheel and Frame Mounting Bracket (Outboard)	1
15	10043-10	Driven Pulley – 3/4" Bore (Key – Part No. 71061)	1
16	10510-01	Drive Wheel Assembly (J-10)	1
	10010-01	Drive Wheel Only (J-10)	1
	10052-00	Ring Gear (Used on J-10 and JH-10)	1
	10510-03	Drive Wheel Assembly (JH-10)	1
	10010-03	Drive Wheel Only (JH-10)	1
	10062-00	Wheel Axle (J-10 & JH-10)	1
	10134-01	Bearing Cup (J-10 & JH-10)	2
	10134-02	Bearing Cone (J-10 & JH-10)	2
	10135-00	Dust Collar (J-10 & JH-10)	2
	10136-00	Snap Ring (J-10 & JH-10)	1

PARTS NOT ILLUSTRATED

PART NO.	DESCRIPTION	QTY
70346	Wheel Mounting Bolt (3/4" – 16 x 1 1/4")	2
14123	Wheel Mounting Bolt Nut (1" – 14)	2
70296	Wheel Mounting Bolt Lock Nut (1" – 14)	2
5143-00	Grease Fitting	1

GEARBOX ASSEMBLY

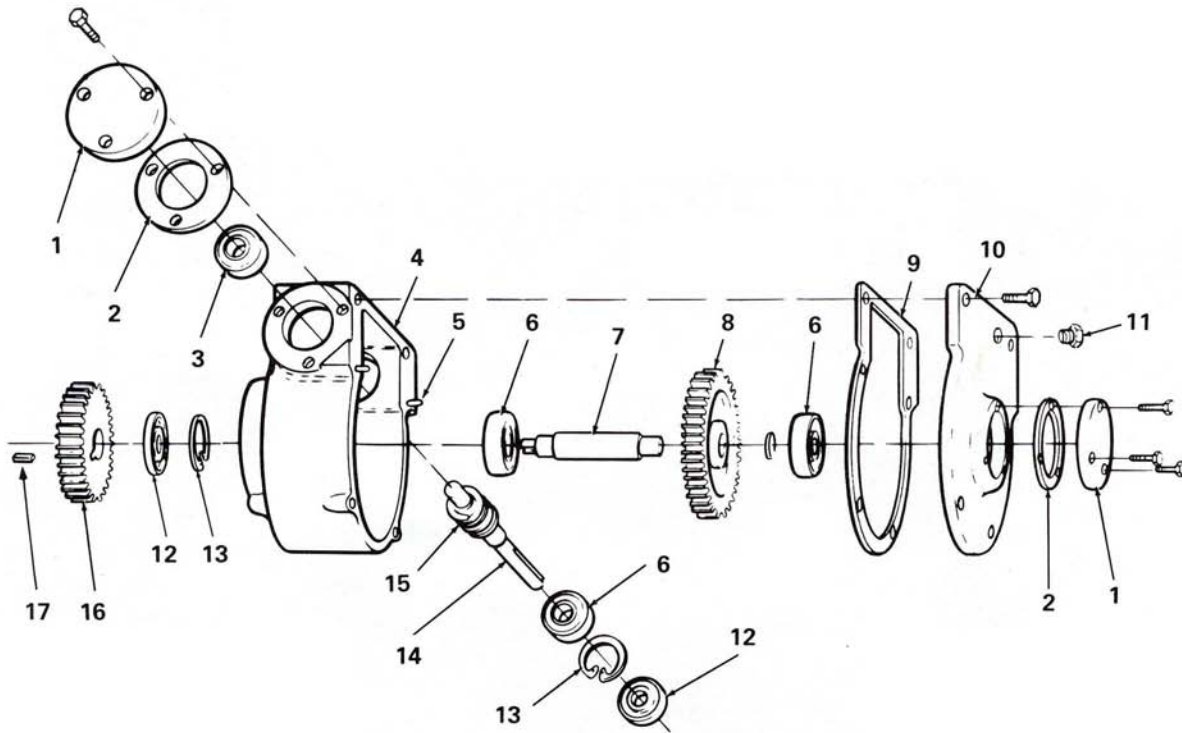

ITEM	PART NO.	DESCRIPTION	QTY
	10544-00	Gear Case Assembly Complete	1
1	5047-00	Bearing Cap	2
2	5138-00	Cap Gasket	2
3	5073-00	Bearing	1
4	5044-00	Gear Case	1
5	3922	Dowel Pin	2
6	5072-00	Bearing	3
7	10049-00	Worm Gear Shaft	1
8 & 15	10050-51	Worm – Steel Worm & Gear Bronze Assembly	1
9	13080-01	Cover Gasket	1
10	5045-00	Gear Case Cover	1
11	7368	Breather Vent	1
12	5137-22	Oil Seal	2
13	5136-00	Snap Ring	2
14	5048-00	Worm Shaft	1
15A	71061	Key (3/16 x 3/16 x 1 3/4")	1
16	10053-00	Spur Gear (Set Screw – Part No. 43558)	1
17	10047-01	Key (3/16 x 3/16 x 1/2")	1
	26189	Woodruff Key (Not Shown)	2
	714706	Bearing & Seal Kit (Includes Items 2,3,6,9,12 & 13)	

HYDRAULIC ASSEMBLY

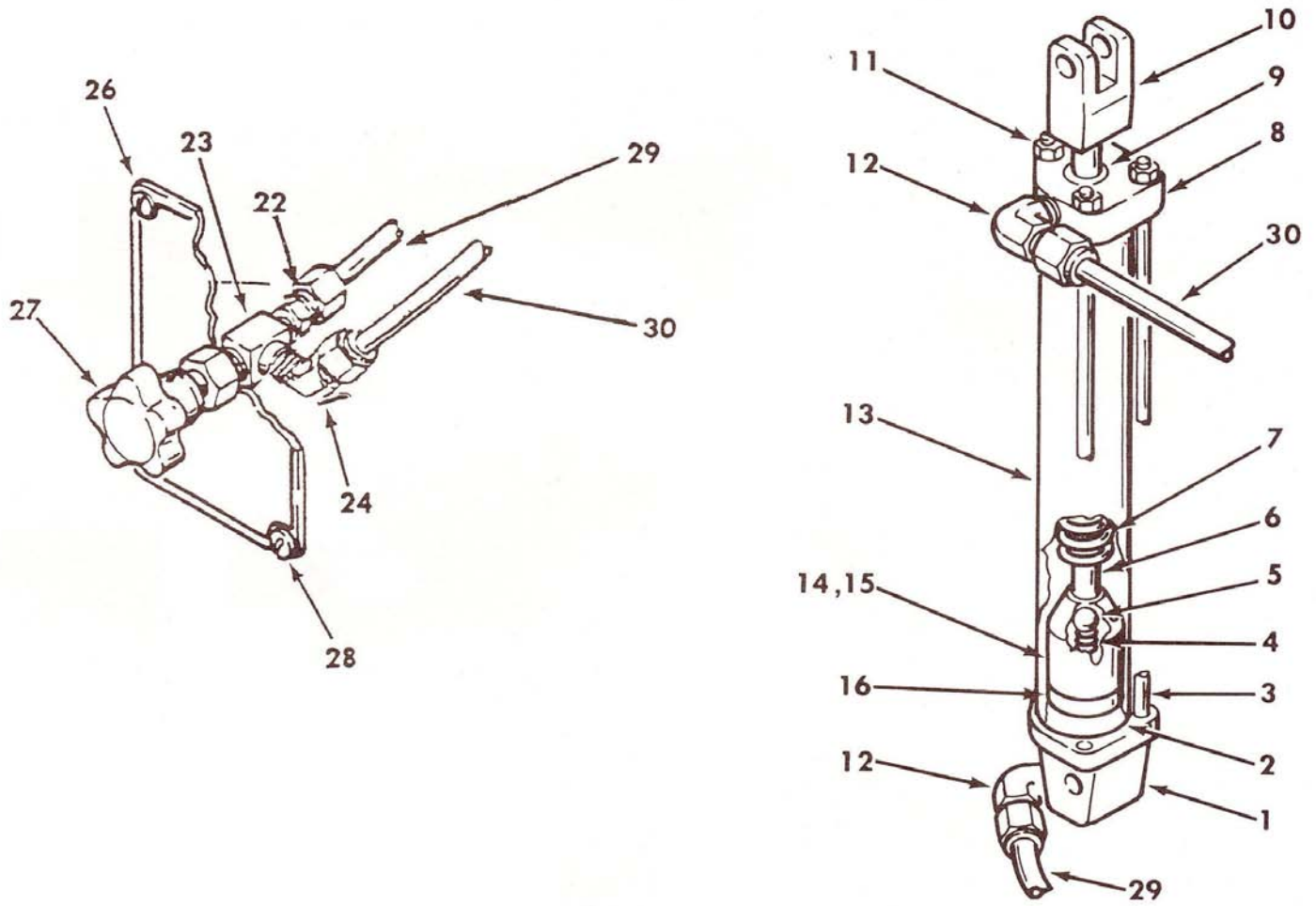

ITEM	PART NO.	DESCRIPTION	QTY
	10530-10	Hydraulic Assembly (Includes Control Valve Assembly)	1
	10530-09	Cylinder Assembly (Only)	1
1	10031-00	Cylinder Base	1
2	10203-03	Fiber Seal	2
3	10205-02	Tie Rod	3
4	5129-00	Spring	1
4A	5116-00	Spring – R Style included in repair kit.	1
5	17817	3/8 inch Ball	1
6	10204-02	Piston Rod	1
7	10033-00	Head Stop Spring	1
8	5030-10	Cylinder Head	1
9	10115-02	Head Seal (O-Ring) – New Models	1
9A	10115-03	Older Models Garlock Shaft Seal (1/2" ID x 7/8" OD x 1/8" Thick)	1
9B	13080-03	Older Models Garlock Shaft Seal (1/2" ID x .801" OD x 1/8" Thick)	1
10	10013-00	Yoke	1
11	43905	10-24 Nut	3
12	71357	Elbow (Includes furrow and nut)	2
13	10203-02	Cylinder Body	1
14	5119-00	Piston	1
15	5120-00	Piston Nut	1
16	5130-00	Leather Cup	1
	10530-08	Control Valve Assembly	1
17	40600-00	Straight Fitting	2
18	1738	Nipple 1/4 x 2-1/2	1
19	70466	Reducer 3/8 x 1/4	1
20	588	3/8 Pipe Plug	1
21	1115	Tee 1/4	1
22	70465	Coupler 1/4 x 1/8	2
23	5131-00	Valve	1
24	44143	90° St. Elbow	1
25	1329	1/8 Close Nipple	2
26	10030-00	Face Plate	1
27	13018-14	Knob	1
28	44349	8 x 32 Screw	4
29	40515-00	5/16 Tubing 7 ft.	1
30	40515-00	5/16 Tubing 8 ft.	1
31	5032-00	Oilier (Not Shown) <i>*Note: Items 18-21 are not needed when saw is equipped with oilier</i>	1
	714717	Hydraulic Cylinder Repair Kit (Includes Items 2, 4, 4A, 5, 9, 9A, 9B & 16)	
	10530-01	Rod & Piston Assembly (Includes Items 4,5,6,14,15 & 16)	

GUIDE ARM ASSEMBLY

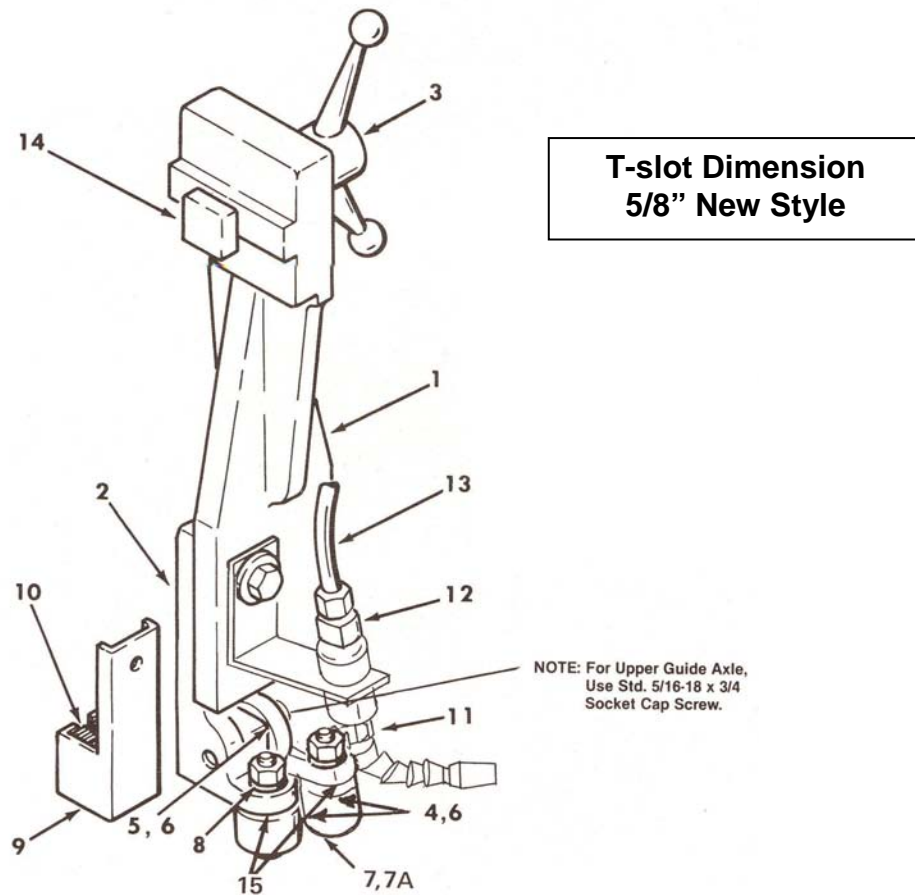

ITEM	PART NO.	DESCRIPTION	QTY
	10519-10	Guide Arm Assembly Complete LH & RH 1" (items 1-8, 14)	2
1	10019-10	Guide Arm LH & RH	1
2	10020-10	Guide Holder	1
3	10084-01	Guide Arm Tightening Handle	1
4	10025-01	Side Guide Bearing	2
5	5026-00	Upper Guide Bearing	1
6	5023-01	Upper Guide Bushing	1
7	10022-02	Inside Concentric Axle	1
7A	5075-00	Side Guide Bushing	1
8	10022-10	Outside Eccentric Axle with Nut & Washer	1
9	5122-00	Brush Holder	1
10	5133	Blade Cleaning Brush Kit – 6 Pairs	1
11	715342	Coolant Nozzle Assembly	1
12	34528	Tube Fitting, Poly-Tite	1
13	67762	Tubing	10 ft.
14	10512-10	T-Bolt	1
15	70462	Spacer Washer (JH Model Only)	8
	10520-10	Guide Holder Assembly (Includes Items 2, 4, 5, 6, 7, 8 & 15)	
	715104	Guide Bearing Kit (Includes Items 4, 5, 6&7A) Will outfit 2 arms	
	75958	Blade, J-Saw – 3/4" x 137" x .035" 5/8 VP – Bi-Metal	
	75957	Blade, JH-Saw – 1" x 137" x .035" 5/8 VP – Bi-Metal	

VISE UNIT

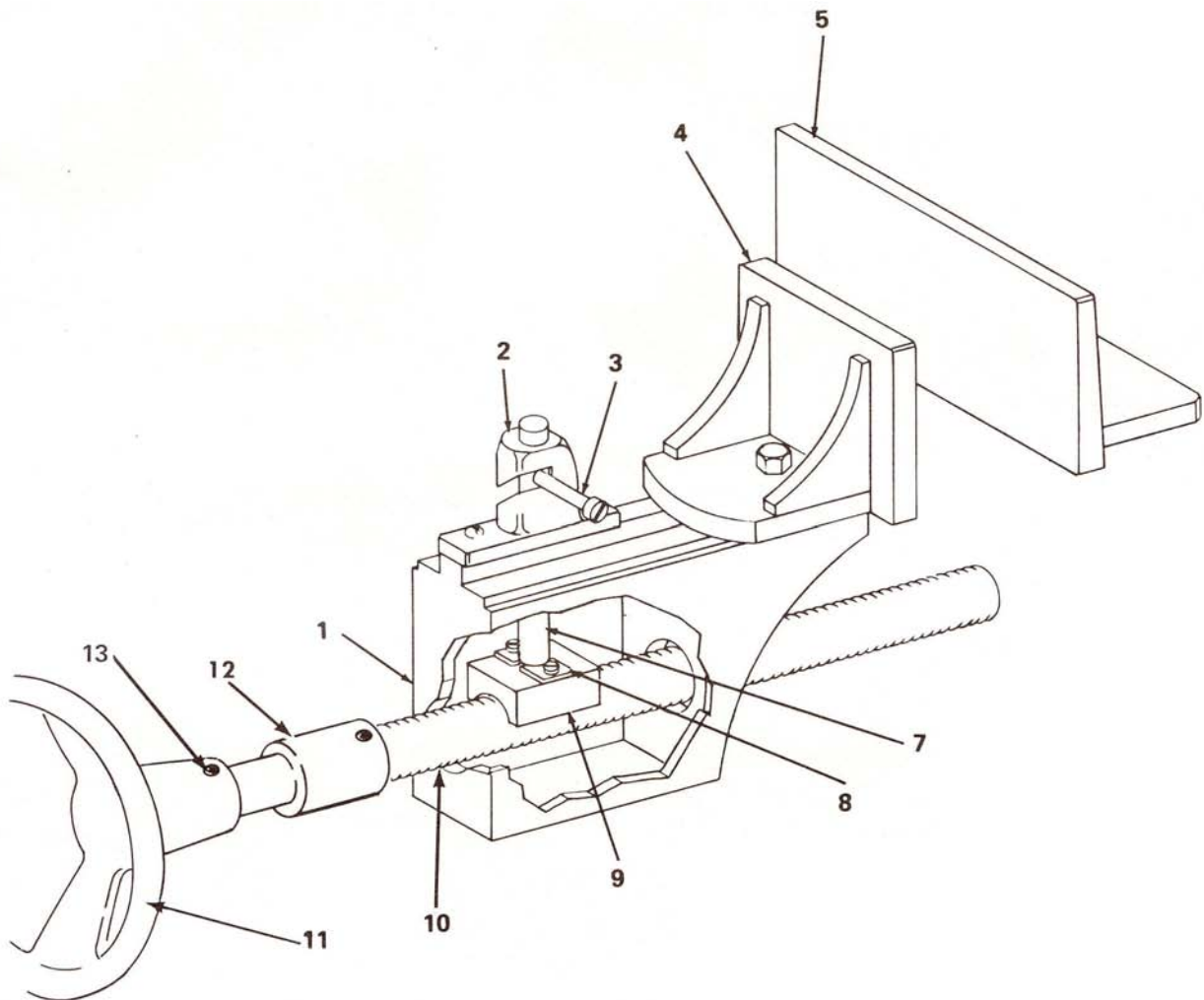

ITEM	PART NO.	DESCRIPTION	QTY
1	10007-00	Hold Down Block	1
2	10099-00	Vise Lift	1
3	5200-00	Handle	1
4	10008-00	Movable Vise Jaw (Bolt – Part No. 43348)	1
5	10009-00	Stationary Vise Jaw (Bolt – Part No. 43348)	1
7	10116-00	Lift Pin	1
8	10201-00	Vise Nut Plate (Self Tapping Screw (10-24) – Part No. 43882)	2
9	10016-00	Vise Nut	1
10	10015-10	Vise Screw	1
11	10014-00	Handwheel	1
12	70464	Stop Collar	1
13	70287	Drive Pin	1 or 2

Metal Band Saws & Cold Saws for Precise, Low-Cost Service Free Sawing.

Horizontal Bandsaws, Vertical Bandsaws and Cold Saws competitively priced.



Arbor and Hydraulic Presses for All Your Application needs.

A complete line of Arbor, H-Frame and custom engineered Hydraulic Presses for production, maintenance and research work.



DAKE Division of JSJ
 724 Robbins Road
 Grand Haven, MI 49417
 Phone: 1-800-937-3253 616-842-7110
 Fax: 1-800-846-3253 616-842-0859
 E-mail: customerservice@dakecorp.com
 technicalservice@dakecorp.com
 Web: www.dakecorp.com

