



OPERATOR'S MANUAL



TUBE AND PIPE NOTCHER MODEL: TN-250

Baileigh Industrial, Inc.
P.O. Box 531
Manitowoc, WI 54221-0531
Phone: 920.684.4990
Fax: 920.684.3944
sales@baileighindustrial.com

REPRODUCTION OF THIS MANUAL IN ANY FORM WITHOUT WRITTEN APPROVAL OF BAILEIGH INDUSTRIAL, INC. IS PROHIBITED. Baileigh Industrial, Inc. does not assume and hereby disclaims any liability for any damage or loss caused by an omission or error in this Operator's Manual, resulting from accident, negligence, or other occurrence.



Table of Contents

THANK YOU & WARRANTY	1
INTRODUCTION.....	3
GENERAL NOTES.....	3
SAFETY INSTRUCTIONS	4
SAFETY PRECAUTIONS	6
TECHNICAL SPECIFICATIONS.....	8
TECHNICAL SUPPORT	8
UNPACKING AND CHECKING CONTENTS.....	9
Cleaning	9
INSTALLATION.....	10
ASSEMBLY AND SET UP	11
OPERATION.....	12
Arbor Adapters	13
MATERIAL SELECTION.....	14
LUBRICATION AND MAINTENANCE	14
PARTS IDENTIFICATION DRAWING	15
Parts Identification List	17



THANK YOU & WARRANTY

Thank you for your purchase of a machine from Baileigh Industrial. We hope that you find it productive and useful to you for a long time to come.

Inspection & Acceptance. Buyer shall inspect all Goods within ten (10) days after receipt thereof. Buyer's payment shall constitute final acceptance of the Goods and shall act as a waiver of the Buyer's rights to inspect or reject the goods unless otherwise agreed. If Buyer rejects any merchandise, Buyer must first obtain a Returned Goods Authorization ("RGA") number before returning any goods to Seller. Goods returned without a RGA will be refused. Seller will not be responsible for any freight costs, damages to goods, or any other costs or liabilities pertaining to goods returned without a RGA. Seller shall have the right to substitute a conforming tender. Buyer will be responsible for all freight costs to and from Buyer and repackaging costs, if any, if Buyer refuses to accept shipment. If Goods are returned in unsalable condition, Buyer shall be responsible for full value of the Goods. Buyer may not return any special order Goods. Any Goods returned hereunder shall be subject to a restocking fee equal to 30% of the invoice price.

Specifications. Seller may, at its option, make changes in the designs, specifications or components of the Goods to improve the safety of such Goods, or if in Seller's judgment, such changes will be beneficial to their operation or use. Buyer may not make any changes in the specifications for the Goods unless Seller approves of such changes in writing, in which event Seller may impose additional charges to implement such changes.

Limited Warranty. Seller warrants to the original end-user that the Goods manufactured or provided by Seller under this Agreement shall be free of defects in material or workmanship for a period of twelve (12) months from the date of purchase, provided that the Goods are installed, used, and maintained in accordance with any instruction manual or technical guidelines provided by the Seller or supplied with the Goods, if applicable. The original end-user must give written notice to Seller of any suspected defect in the Goods prior to the expiration of the warranty period. The original end-user must also obtain a RGA from Seller prior to returning any Goods to Seller for warranty service under this paragraph. Seller will not accept any responsibility for Goods returned without a RGA. The original end-user shall be responsible for all costs and expenses associated with returning the Goods to Seller for warranty service. In the event of a defect, Seller, at its sole option, shall repair or replace the defective Goods or refund to the original end-user the purchase price for such defective Goods. Goods are not eligible for replacement or return after a period of 30 days from date of receipt. The foregoing warranty is Seller's sole obligation, and the original end-user's exclusive remedy, with regard to any defective Goods. This limited warranty does not apply to: (a) die sets, tooling, and saw blades; (b) periodic or routine maintenance and setup, (c) repair or replacement of the Goods due to normal wear and tear, (d) defects or damage to the Goods resulting from misuse, abuse, neglect, or accidents, (e) defects or damage to the Goods resulting from improper or unauthorized alterations, modifications, or changes; and (f) any Goods that has not been installed and/or maintained in accordance with the instruction manual or technical guidelines provided by Seller.

EXCLUSION OF OTHER WARRANTIES. THE FOREGOING LIMITED WARRANTY IS IN LIEU OF ALL OTHER WARRANTIES, EXPRESS OR IMPLIED. ANY AND ALL OTHER EXPRESS, STATUTORY OR IMPLIED WARRANTIES, INCLUDING BUT NOT LIMITED TO, ANY WARRANTY OF MERCHANTABILITY OR FITNESS FOR ANY PARTICULAR PURPOSE ARE EXPRESSLY DISCLAIMED. NO WARRANTY IS MADE WHICH EXTENDS BEYOND THAT WHICH IS EXPRESSLY CONTAINED HEREIN.

Limitation of Liability. IN NO EVENT SHALL SELLER BE LIABLE TO BUYER OR ANY OTHER PARTY FOR ANY INCIDENTAL, CONSEQUENTIAL OR SPECIAL DAMAGES (INCLUDING, WITHOUT LIMITATION, LOST PROFITS OR DOWN TIME) ARISING FROM OR IN MANNER CONNECTED WITH THE GOODS, ANY BREACH BY SELLER OR ITS AGENTS OF THIS AGREEMENT, OR ANY OTHER CAUSE WHATSOEVER, WHETHER BASED ON CONTRACT, TORT OR ANY OTHER THEORY OF LIABILITY. BUYER'S REMEDY WITH RESPECT TO ANY CLAIM ARISING UNDER THIS AGREEMENT IS STRICTLY LIMITED TO NO MORE THAN THE AMOUNT PAID BY THE BUYER FOR THE GOODS.



Force Majeure. Seller shall not be responsible for any delay in the delivery of, or failure to deliver, Goods due to causes beyond Seller's reasonable control including, without limitation, acts of God, acts of war or terrorism, enemy actions, hostilities, strikes, labor difficulties, embargoes, non-delivery or late delivery of materials, parts and equipment or transportation delays not caused by the fault of Seller, delays caused by civil authorities, governmental regulations or orders, fire, lightening, natural disasters or any other cause beyond Seller's reasonable control. In the event of any such delay, performance will be postponed by such length of time as may be reasonably necessary to compensate for the delay.

Installation. If Buyer purchases any Goods that require installation, Buyer shall, at its expense, make all arrangements and connections necessary to install and operate the Goods. Buyer shall install the Goods in accordance with any Seller instructions and shall indemnify Seller against any and all damages, demands, suits, causes of action, claims and expenses (including actual attorneys' fees and costs) arising directly or indirectly out of Buyer's failure to properly install the Goods.

Work By Others; Safety Devices. Unless agreed to in writing by Seller, Seller has no responsibility for labor or work performed by Buyer or others, of any nature, relating to design, manufacture, fabrication, use, installation or provision of Goods. Buyer is solely responsible for furnishing, and requiring its employees and customers to use all safety devices, guards and safe operating procedures required by law and/or as set forth in manuals and instruction sheets furnished by Seller. Buyer is responsible for consulting all operator's manuals, ANSI or comparable safety standards, OSHA regulations and other sources of safety standards and regulations applicable to the use and operation of the Goods.

Remedies. Each of the rights and remedies of Seller under this Agreement is cumulative and in addition to any other or further remedies provided under this Agreement or at law or equity.

Attorney's Fees. In the event legal action is necessary to recover monies due from Buyer or to enforce any provision of this Agreement, Buyer shall be liable to Seller for all costs and expenses associated therewith, including Seller's actual attorneys' fees and costs.

Governing Law/Venue. This Agreement shall be construed and governed under the laws of the State of Wisconsin, without application of conflict of law principles. Each party agrees that all actions or proceedings arising out of or in connection with this Agreement shall be commenced, tried, and litigated only in the state courts sitting in Manitowoc County, Wisconsin or the U.S. Federal Court for the Eastern District of Wisconsin. Each party waives any right it may have to assert the doctrine of "forum non conveniens" or to object to venue to the extent that any proceeding is brought in accordance with this section. Each party consents to and waives any objection to the exercise of personal jurisdiction over it by courts described in this section. Each party waives to the fullest extent permitted by applicable law the right to a trial by jury.

Summary of Return Policy.

- 10 Day acceptance period from date of delivery. Damage claims and order discrepancies will not be accepted after this time.
- You must obtain a Baileigh issued RGA number PRIOR to returning any materials.
- Returned materials must be received at Baileigh in new condition and in original packaging.
- Altered items are not eligible for return.
- Buyer is responsible for all shipping charges.
- A 30% re-stocking fee applies to all returns.

Baileigh Industrial makes every effort to ensure that our posted specifications, images, pricing and product availability are as correct and timely as possible. We apologize for any discrepancies that may occur. Baileigh Industrial reserves the right to make any and all changes deemed necessary in the course of business including but not limited to pricing, product specifications, quantities, and product availability.

For Customer Service & Technical Support:

Please contact one of our knowledgeable Sales and Service team members at: (920) 684-4990 or e-mail us at sales@baileighindustrial.com



INTRODUCTION

The quality and reliability of the components assembled on a Baileigh Industrial machine guarantee near perfect functioning, free from problems, even under the most demanding working conditions. However if a situation arises, refer to the manual first. If a solution cannot be found, contact the distributor where you purchased our product. Make sure you have the serial number and production year of the machine (stamped on the nameplate). For replacement parts refer to the assembly numbers on the parts list drawings.

Our technical staff will do their best to help you get your machine back in working order.

In this manual you will find: (when applicable)

- Safety procedures
- Correct installation guidelines
- Description of the functional parts of the machine
- Capacity charts
- Set-up and start-up instructions
- Machine operation
- Scheduled maintenance
- Parts lists

GENERAL NOTES

After receiving your equipment remove the protective container. Do a complete visual inspection, and if damage is noted, **photograph it for insurance claims** and contact your carrier at once, requesting inspection. Also contact Baileigh Industrial and inform them of the unexpected occurrence. Temporarily suspend installation.

Take necessary precautions while loading / unloading or moving the machine to avoid any injuries.

Your machine is designed and manufactured to work smoothly and efficiently. Following proper maintenance instructions will help ensure this. Try and use original spare parts, whenever possible, and most importantly; **DO NOT** overload the machine or make any unauthorized modifications.



Note: This symbol refers to useful information throughout the manual.



IMPORTANT **PLEASE READ THIS OPERATORS MANUAL CAREFULLY**

It contains important safety information, instructions, and necessary operating procedures. The continual observance of these procedures will help increase your production and extend the life of the equipment.



SAFETY INSTRUCTIONS

LEARN TO RECOGNIZE SAFETY INFORMATION

This is the safety alert symbol. When you see this symbol on your machine or in this manual, **BE ALERT TO THE POTENTIAL FOR PERSONAL INJURY!**



Follow recommended precautions and safe operating practices.

UNDERSTAND SIGNAL WORDS

A signal word – **DANGER**, **WARNING**, or **CAUTION** is used with the safety alert symbol. **DANGER** identifies a hazard or unsafe practice that will result in severe **Injury or Death.**



Safety signs with signal word **DANGER** or **WARNING** are typically near specific hazards.



General precautions are listed on **CAUTION** safety signs. **CAUTION** also calls attention to safety messages in this manual.





SAVE THESE INSTRUCTIONS.
Refer to them often and use them to instruct others.



PROTECT EYES

Wear safety glasses or suitable eye protection when working on or around machinery.

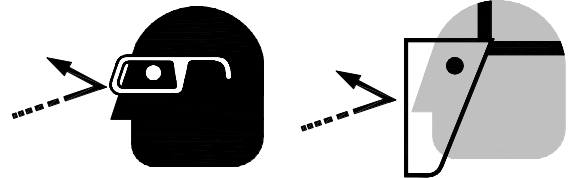

PROTECT AGAINST NOISE

Prolonged exposure to loud noise can cause impairment or loss of hearing. Wear suitable hearing protective devices such as ear muffs or earplugs to protect against objectionable or uncomfortable loud noises.

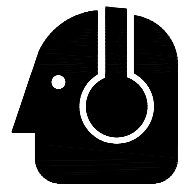

BEWARE OF PIERCING POINTS

NEVER place hands, fingers, or any part of your body near rotating tools. Hole saws are very sharp and can quickly pierce your fingers and hands. Always wear heavy leather gloves when handling these tools.

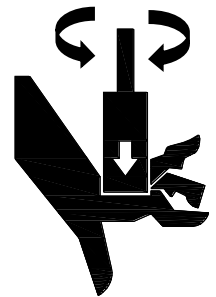

ENTANGLEMENT HAZARD – ROTATING SPINDLE

Contain long hair, **DO NOT** wear jewelry or loose fitting clothing.





SAFETY PRECAUTIONS



Metal working can be dangerous if safe and proper operating procedures are not followed. As with all machinery, there are certain hazards involved with the operation of the product. Using the machine with respect and caution will considerably lessen the possibility of personal injury. However, if normal safety precautions are overlooked or ignored, personal injury to the operator may result.

Safety equipment such as guards, hold-downs, safety glasses, dust masks and hearing protection can reduce your potential for injury. But even the best guard won't make up for poor judgment, carelessness or inattention. **Always use common sense** and exercise **caution** in the workshop. If a procedure feels dangerous, don't try it.

REMEMBER: Your personal safety is your responsibility.



WARNING: FAILURE TO FOLLOW THESE RULES MAY RESULT IN SERIOUS PERSONAL INJURY

1. **Only trained and qualified personnel can operate this machine.**
2. **Make sure guards are in place and in proper working order before operating machinery.**
3. **Remove any adjusting tools.** Before operating the machine, make sure any adjusting tools have been removed.
4. **Keep work area clean.** Cluttered areas invite injuries.
5. **Overloading machine.** By overloading the machine you may cause injury from flying parts. **DO NOT** exceed the specified machine capacities.
6. **Dressing material edges.** Always chamfer and deburr all sharp edges.
7. **Do not force tool.** Your machine will do a better and safer job if used as intended. **DO NOT** use inappropriate attachments in an attempt to exceed the machines rated capacity.
8. **Use the right tool for the job. DO NOT** attempt to force a small tool or attachment to do the work of a large industrial tool. **DO NOT** use a tool for a purpose for which it was not intended.
9. **Dress appropriate. DO NOT** wear loose fitting clothing or jewelry as they can be caught in moving machine parts. Protective clothing and steel toe shoes are recommended when using machinery. Wear a restrictive hair covering to contain long hair.
10. **Use eye and ear protection.** Always wear ISO approved impact safety goggles. Wear a full-face shield if you are producing metal filings.



11. **Do not overreach.** Maintain proper footing and balance at all times. **DO NOT** reach over or across a running machine.
12. **Stay alert.** Watch what you are doing and use common sense. **DO NOT** operate any tool or machine when you are tired.
13. **Check for damaged parts.** Before using any tool or machine, carefully check any part that appears damaged. Check for alignment and binding of moving parts that may affect proper machine operation.
14. **Observe work area conditions.** **DO NOT** use machines or power tools in damp or wet locations. Do not expose to rain. Keep work area well lighted. **DO NOT** use electrically powered tools in the presence of flammable gases or liquids.
15. **Blade adjustments and maintenance.** Always keep blades sharp and properly adjusted for optimum performance.
16. **Keep children away.** Children must never be allowed in the work area. **DO NOT** let them handle machines, tools, or extension cords.
17. **Store idle equipment.** When not in use, tools must be stored in a dry location to inhibit rust. Always lock up tools and keep them out of reach of children.
18. **DO NOT operate machine if under the influence of alcohol or drugs.** Read warning labels on prescriptions. If there is any doubt, **DO NOT** operate the machine.
19. **Do not** cut where the atmosphere might contain flammable dust, gas, or liquid vapors such as from gasoline.
20. **DO NOT** touch live electrical components or parts.
21. **Turn off** power before checking, cleaning, or replacing any torch parts.
22. Be sure **all** equipment is properly installed and grounded according to national, state, and local codes.
23. Inspect power and control cables periodically. Replace if damaged or bare wires are exposed. **Bare wiring can kill!**
24. Keep visitors a safe distance from the work area.



TECHNICAL SPECIFICATIONS

TN-250	Imperial	Metric
Notching Capacity (OD)	0.5" – 2.5"	12.7mm – 63.5mm
Angle Adjustment	Infinite	
Power Requirements	1/2" (12.7mm) Powered Hand Drill	
Shipping Dimensions	24" x 12" x 12"	610mm x 305mm x 305mm
Shipping Weight	50 lbs.	23 kgs.

FEATURES

- Solid steel construction
- Grade 8 bolts throughout, ensuring maximum rigidity
- Unique 6 jaw radial vise
- Will notch over 75°
- 1-1/4" hardened Thomson shaft with replaceable tips
- Slotted carriage for offset notches (no shims)
- Patent pending

TECHNICAL SUPPORT

Our technical support department can be reached at 920.684.4990, and asking for the support desk for purchased machines. Tech Support handles questions on machine setup, schematics, warranty issues, and individual parts needs: (other than die sets and blades).

For specific application needs or future machine purchases contact the Sales Department at: sales@baileighindustrial.com, Phone: 920.684.4990, or Fax: 920.684.3944.



Note: The photos and illustrations used in this manual are representative only and may not depict the actual color, labeling or accessories and may be intended to illustrate technique only.



Note: The specifications and dimensions presented here are subject to change without prior notice due to improvements of our products.



UNPACKING AND CHECKING CONTENTS

Your Baileigh machine is shipped complete in one package. Separate all parts from the packing material and check each item carefully. Make certain all items are accounted for before discarding any packing material.

⚠ WARNING: SUFFOCATION HAZARD! Immediately discard any plastic bags and packing materials to eliminate choking and suffocation hazards to children and animals.
If any parts are missing, do not plug in the power cable, or turn the power switch on until the missing parts are obtained and installed correctly.

Cleaning

⚠ WARNING: DO NOT USE gasoline or other petroleum products to clean the machine. They have low flash points and can explode or cause fire.

⚠ CAUTION: When using cleaning solvents work in a well-ventilated area. Many cleaning solvents are toxic if inhaled.

Your machine may be shipped with a rustproof waxy coating and/or grease on the exposed unpainted metal surfaces. Fully and completely remove this protective coating using a degreaser or solvent cleaner. Moving items will need to be moved along their travel path to allow for cleaning the entire surface. For a more thorough cleaning, some parts will occasionally have to be removed. **DO NOT USE** acetone or brake cleaner as they may damage painted surfaces.

Follow manufacturer's label instructions when using any type of cleaning product. After cleaning, wipe unpainted metal surfaces with a light coating of quality oil or grease for protection.



Important: This waxy coating is **NOT** a lubricant and will cause the machine to stick and lose performance as the coating continues to dry





INSTALLATION

IMPORTANT:

Consider the following when looking for a suitable location to place the machine:

- Overall weight of the machine.
- Weight of material being processed.
- Sizes of material to be processed through the machine.
- Space needed for auxiliary stands, work tables, or other machinery.
- Clearance from walls and other obstacles.
- Maintain an adequate working area around the machine for safety.
- Have the work area well illuminated with proper lighting.
- Keep the floor free of oil and make sure it is not slippery.
- Remove scrap and waste materials regularly, and make sure the work area is free from obstructing objects.
- If long lengths of material are to be fed into the machine, make sure that they will not extend into any aisles.



ASSEMBLY AND SET UP

⚠ WARNING: For your own safety, **DO NOT** connect a powered drill until the machine is completely assembled and you have read and understand the entire instruction manual.

1. Install the hand wheel onto the hub with the supplied 5/16-18 socket head screws.



2. Attach the pivot block and indicator assembly onto the vise assembly using the 1/2-13 bolts and the retaining plate supplied.
3. The pivot block will fit into the machined recess in the vise assembly plate.
4. The retaining plate will go on the opposite side of the vise assembly and is there to act as a support washer so as not to damage the vise plate from frequent tightening.





OPERATION

⚠ CAUTION: Always wear proper eye protection with side shields, safety footwear, and leather gloves to protect from burrs and sharp edges.

1. Operating your **TN-250** is very easy, but certain steps need to be followed.
2. After your notcher is assembled, it needs to be clamped into a vise or bolted to the side of a workbench. The main vise plate has a machined step that is designed to make insertion into vise jaws very easy.
3. Choose a hole saw that matches your materials outside diameter and screw it onto the threaded stud on the end of the main shaft arbor.
4. If you will be notching on center, check the height scale on the left side of the notcher and make sure the pivot clamp block is in the zero position. If an offset notch is required, loosen the two hex screws using a 3/8 hex key wrench and adjust it to the desired offset.
5. Open your vise assembly using the 3 legged hand wheel and insert the desired tubing that needs to be notched. The amount of tubing protruding past the vise will be determined by the angle of notch, and the hole saw should be slid forward to set that distance.
6. Tighten the material, being careful not to over tighten and crush your tube, as the vise has supreme holding power.
7. If an angle notch is required, loosen the two hex bolts on the side of the clamp block with a 3/8" hex key. Position the pivot arm to the desired angle. And re-tighten. Angles up to 45 degrees work best using the center slot in the pivot arm, the second slot is used for extreme angles and for notching on curved tubes as it aides in offsetting further.
8. When the desired angle is set, the aluminum bearing block should be slid as far forward as possible to the notch, this will make the cutting as rigid as possible. Be sure to tighten the two hex bolts beneath the aluminum block using a 3/8" hex key.
9. A 1/2" drive electric drill will need to be chucked onto the hexed arbor, and tightened securely.





IMPORTANT: It is recommended to use a drill with a keyed chuck to tighten the chuck securely onto the hexed arbor. Recheck the chuck periodically to ensure it remains tight to the hexed arbor. Allowing the chuck to become loose on the hex arbor will accelerate the wear on the hex drive stud.

10. Insure that the hole saw is not in contact with the material and start the drill.

11. Slowly push the arbor forward allowing the hole saw to do the work, and do not push too hard.

- Keeping the speed around 250 rpm provides the best combination of saw cut and saw life.
- In some instances, the hole saw will bottom out requiring the slug to be cut out with a zip wheel to continue the notch, this is normal with this type of machine. Sometimes the pivot arm can be swung back 180 degrees to finish a notch, but again probably only up to 45 degrees will this method work.
- Angle notches over 45 degrees should be sawed to the angle first, to remove the majority of the material.
- Following these simple steps will give you years of trouble free service from your TN-250 notcher.

Arbor Adapters

When setting up the notcher, use the correct arbor to saw adapter to fit the size and manufacturer of the hole saw being used.

Contact the Baileigh Industrial to order optional or replacement adapters.

			Hole Saw End
			Arbor End
Standard Adapter. Used with most hole saws.	Reducer Adapter. Used with small hole saws.	Optional Adapter. Larger M18 end to fit certain hole saws manufacturer saws.	



MATERIAL SELECTION

⚠ CAUTION: It must be determined by the customer that materials being processed through the machine are **NOT** potentially hazardous to operator or personnel working nearby.

When selecting materials keep these instructions in mind:

- Material must be clean and dry. (without oil)
- Material should have a smooth surface so it processes easily.
- Dimensional properties of material must be consistent and not exceed the machine capacity values.
- Chemical structure of material must be consistent.
- Buy certificated steel from the same vendor when possible.

LUBRICATION AND MAINTENANCE



Note: *Proper maintenance can increase the life expectancy of your machine.*

- Check for any loose or worn parts; contact your dealer for replacement parts.
- Fluid level in aluminum housing should be checked periodically, add 80w gear oil if fluid levels are low. When completely empty, the aluminum block will hold 1 oz. of oil.
- Replacement seals, bearings, threaded hole saw studs, and drive hexes are all available to keep your machine running for years.
- Replace the hexed drive stud when it becomes worn.



PARTS IDENTIFICATION DRAWING

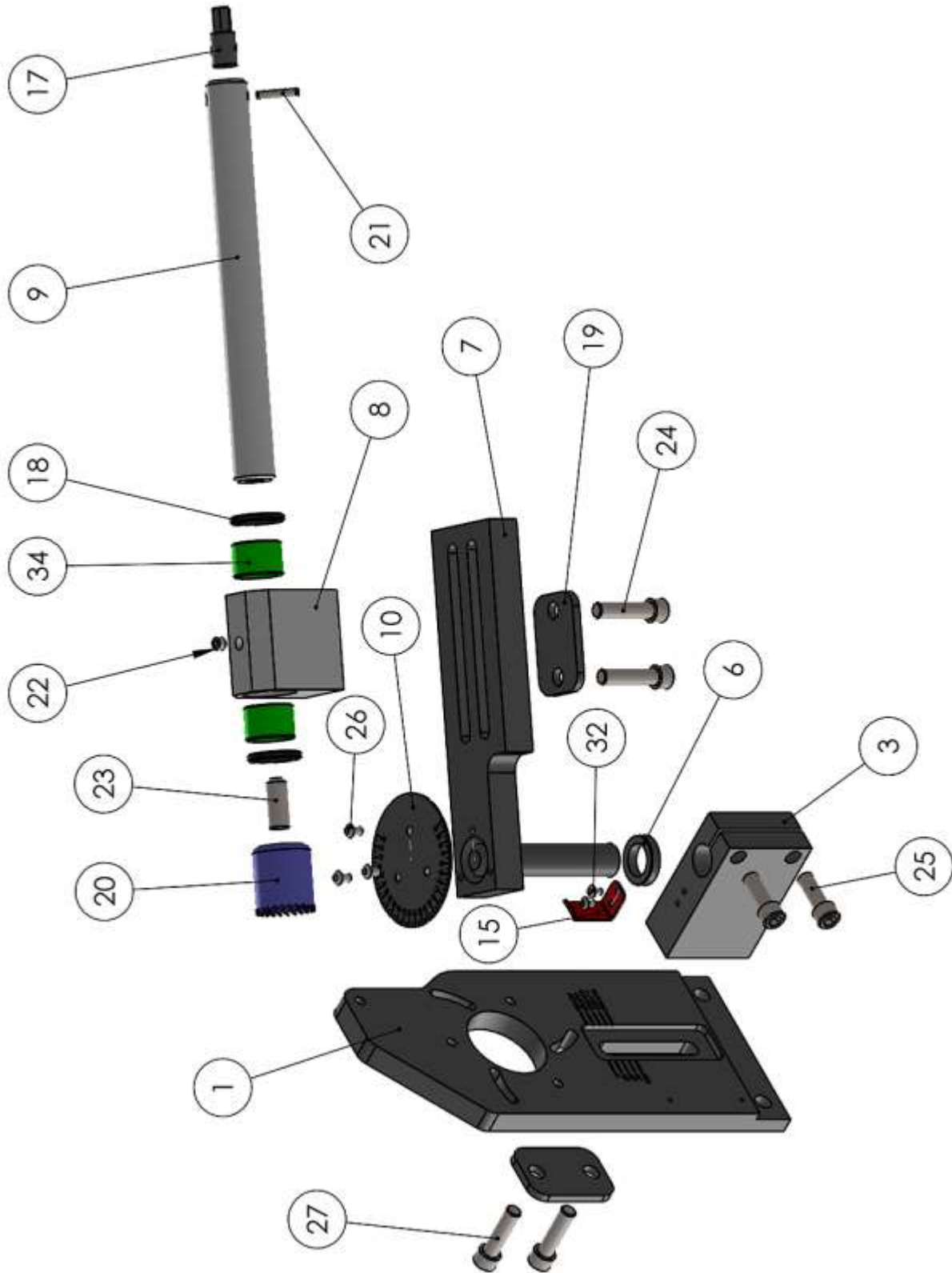

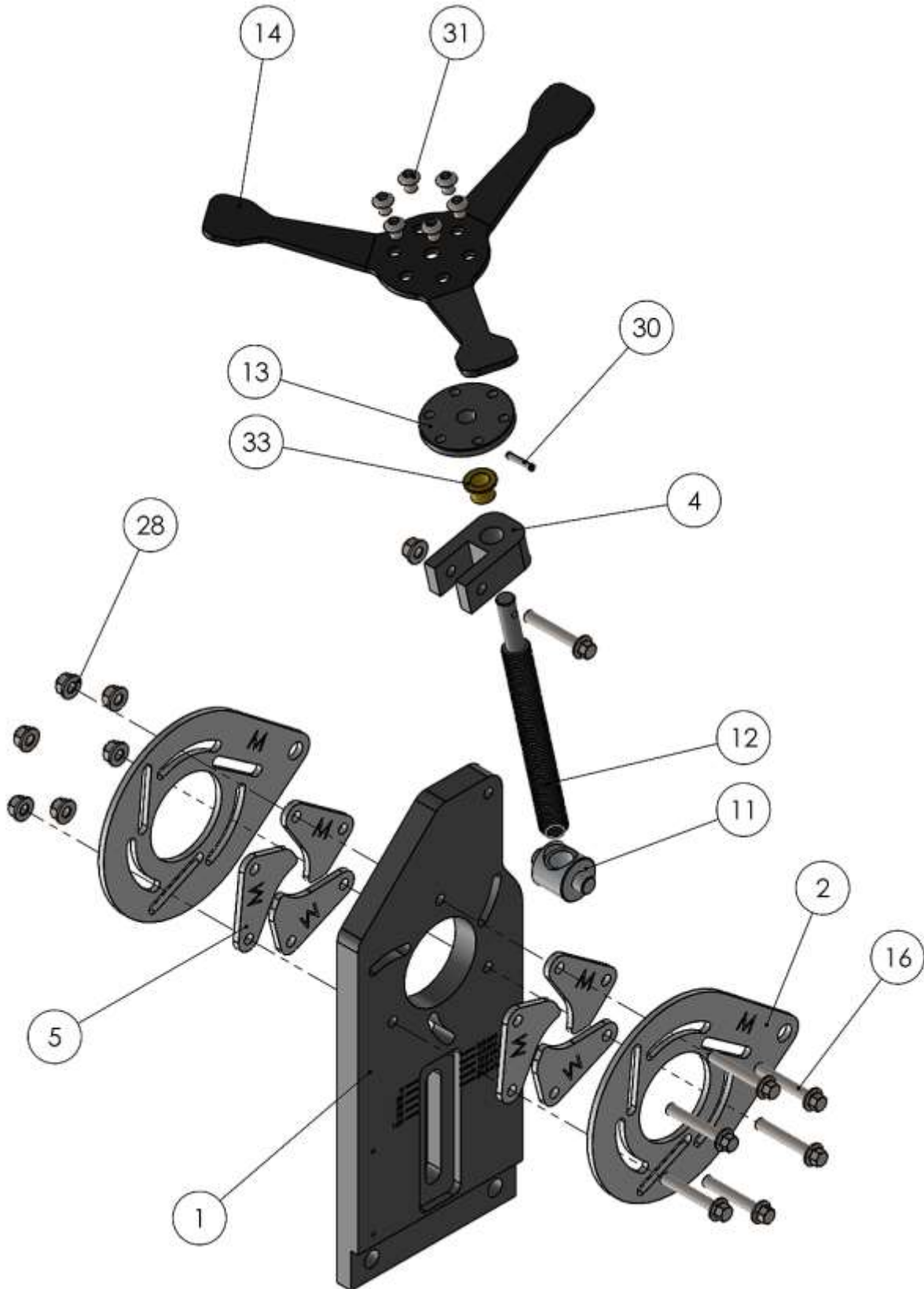



Parts Identification List

Item	Part Number	Description	Qty.
1	ME-TN250-6A016	MAIN FRAME	1
2	ME-TN250-6A009	ACTUATOR PLATE	2
3	ME-TN250-6A011	PIVOT CLAMP BLOCK	1
4	ME-TN250-6A015	ROCKER BLOCK	1
5	ME-TN250-6A021	GRIPPER JAW	6
6	TN250-7A014	SPACER	1
7	ME-TN250-5A001	PIVOT ARM ASSY	1
8	ME-TN250-6A013	BRG BLOCK	1
9	TN250-7A001	SAW ARBOR	1
10	TN250-6A017	DEGREE DISC	1
11	TN250-7A007	TRUNION	1
12	TN250-7A006	WISE SCREW	1
13	ME-TN250-7A008	WHEEL HUB	1
14	M300-6A066	HAND WHEEL	1
15	ME-TN250-6A022	POINTER	1
16	STD.	M8 X 1.25 X 50 HEX FLANGE	7
17	ME-TN250-7A010	DRIVE STUD	1
18	PP-1142	SEAL	2
19	TN250-6A014	BOLT CAP	2
20	NOT INCLUDED	HOLE SAW	1
21	STD.	.25 X 1.25 SLOTTED SPLIT PIN	1
22	STD.	3/8-24 X 5/16 SET SCREW	1
23	Imperial	Adapter, Standard 5/8-18 X 1.25 Set Screw	1
23-A	M600-7A006	Adapter, Reducer 5/8-18 x .5 to 1/2-20 x 1/2	1
23-B	M600-7A009	Adapter, Enlarger 5/8-18 x .5 to M18-1.5 x 10	Optional
24	M12 X 1.75 X 50	SHCS	2
25	M12 X 1.75 X 35	SHCS	2
26	M6 X 1.0 X 10	BUTTON HEAD	3
27	M12 X 1.75 X 45	SHCS	2
28	M8 X 1.25	FLANGED NYLOCK NUT	7
30	STD.	3/16 X 7/8 SLOTTED SPLIT PIN	1
31	M8 X 1.25 X 10	BUTTON HEAD	6
32	M5 X 0.8 X 8	BUTTON HEAD	2



Item	Part Number	Description	Qty.
33	PP-0196	0.5 ID X 0.625 OD X 0.562 LG	1
34	PP-1141	NEEDLE BEARING	2

BAILEIGH INDUSTRIAL, INC. 1625 DUFEK DRIVE MANITOWOC, WI 54220
PHONE: 920. 684. 4990 FAX: 920. 684. 3944
www.baileigh.com

BAILEIGH INDUSTRIAL, INC. 1455 S. CAMPUS AVENUE ONTARIO, CA 91761
PHONE: 920. 684. 4990 FAX: 920. 684. 3944

BAILEIGH INDUSTRIAL LTD. UNIT D SWIFT POINT
SWIFT VALLEY INDUSTRIAL ESTATE, RUGBY
WEST MIDLANDS, CV21 1QH UNITED KINGDOM
PHONE: +44 (0)24 7661 9267 FAX: +44 (0)24 7661 9276
WWW.BAILEIGHINDUSTRIAL.CO.UK

BAILEIGH INDUSTRIAL PTY. LTD.
P.O Box 1573, 126 MELROSE DRIVE TULLAMARINE,
VIC 3043 AUSTRALIA
WWW.BAILEIGHINDUSTRIAL.COM.AU