

NO. XX HAND PUNCH

Instructions and Parts List

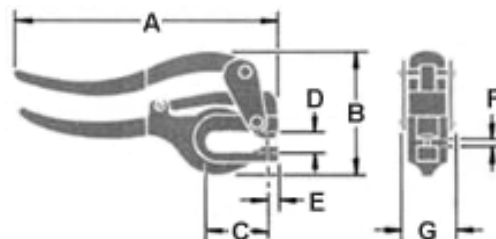

NO. XX TOOL IN KIT



DIMENSIONS: NO. XX

Reference	IN.	MM
A	10 1/4	260.35
B	6 3/8	161.93
C	3 1/4	82.55
D	2 1/8	53.98
E	9/16	14.29
F	9/16	14.29
G	1 5/8	41.28

CARE: Oil at hinge points, the punch guide hole in the lower handle, and the punch point is all the care necessary.

OPERATION: To change punch and die, first loosen die set screw (10) and unscrew die from lower handle using key (13). Loosen punch set screw (11) and slide punch down through die hole of frame. Reverse the above procedure to install the desired size of punch and die. Dies are threaded into lower handle. To avoid breakage; use die key to remove die or screwdriver wide enough to engage both slots. Die should be set high enough so punch can remove slug. Bench mounting base use requires three 5/16" holes drilled in bench. OUR DIES WILL NOT FIT Duro Dyne or Parker Kalon No. XX Deep Throat Hand Punches until a 3/4-16 thread tap is run through the lower handle.

FOR MAXIMUM OPERATOR SAFETY DO:

1. Read and understand this manual.
2. Use only XX punches and dies marked with a W or R-W designed for this tool.
3. Be sure you punch within the one ton capacity of this tool. Type and thickness of material versus final hole size will give you this tonnage.
4. Wear safety glasses.

FOR MAXIMUM OPERATOR SAFETY DO NOT:

1. Use punches and dies that are chipped or dulled.
2. Punch over capacity of the tool.
3. Nibble. Punch a full hole, not a half hole, as punch may contact die.

NO. XX HAND PUNCH

Instructions and Parts List

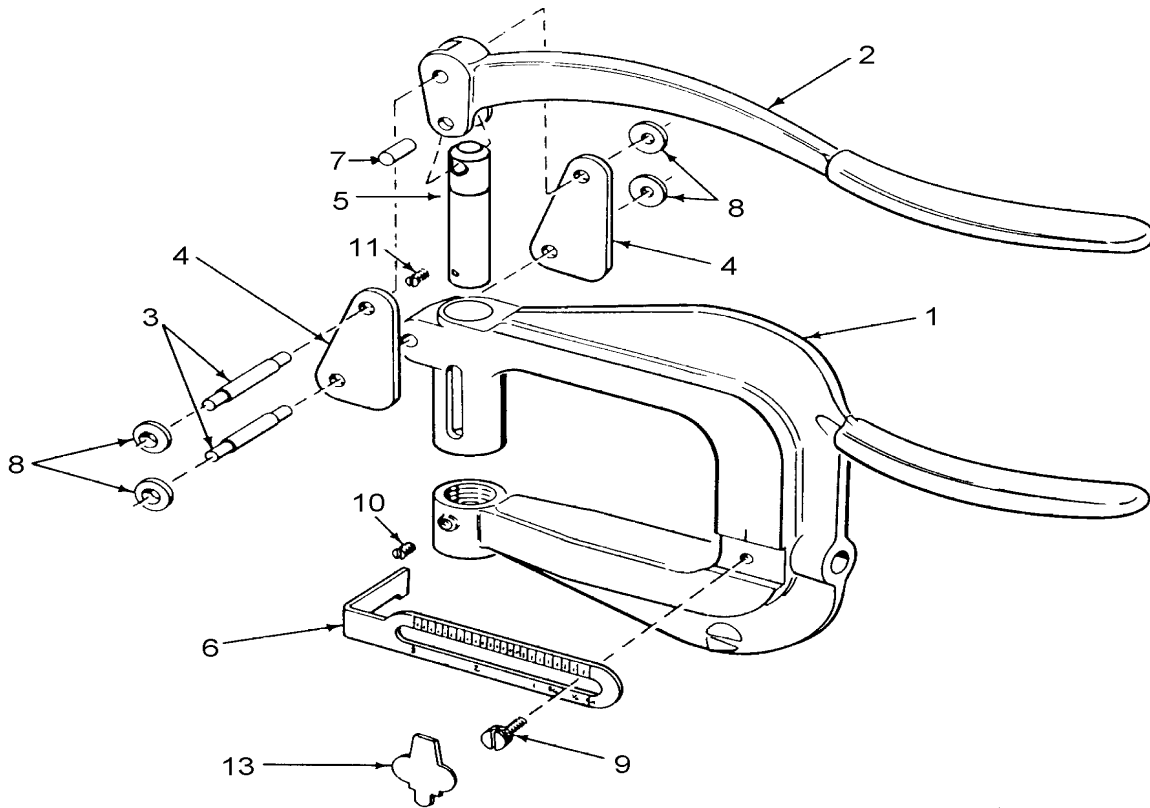

ITEM NO.	PART NO.	PART NAME	QTY.
1	730460019	Lower Handle	1
2	730460020	Upper Handle	1
3	730160021	Pin	2
4	730240022	Side Link	2
5	730010023	Punch Holder	1
6	730420024	Gauge	1
7	730160025	Pin	1
8	730830008	Washer	4
9	730650011	Screw	1
10	600325900	Headless Set Screw, 12-32 x 1/4	1
11	600325900	Headless Set Screw, 12-32 x 1/4	1
12	630000107	Plastic Box (not shown)	1
13	730480009	Key	1
14	235800012	12 Pack Set Screws (not shown)	1

Distributed by: **Trick-Tools.com**

Trick-Tools
80 Truman Road
Pella, IA 50219

Phone:1-877-VAN-SANT
E-mail: sales@trick-tools.com



Here at Trick Tools we believe that our customers deserve the best value in their tool and equipment purchases. We are constantly at work searching out a variety of high quality, high performance tools to offer at the best prices possible. Our commitment to you is that we will not offer “cheap junk” anywhere on our website. You, the customer, help us to evaluate our products constantly and as soon as an ongoing quality issue is uncovered we will correct it or discontinue that product immediately. We hope to earn your continued trust.