

ELITE

HIGH PERFORMANCE MACHINERY

Operating Instructions and Parts Manual

MILL

Models: ETM-949 and ETM-949EVS

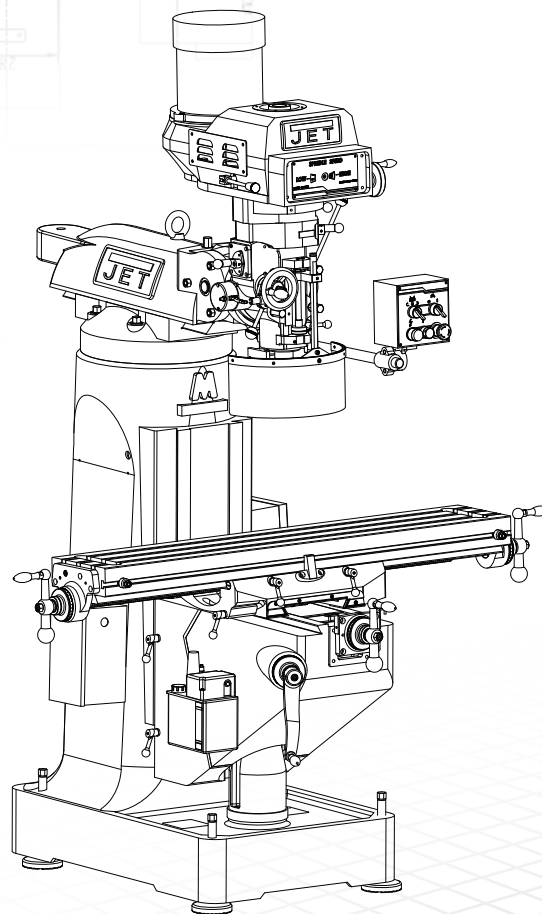

Part No. M-894010

REV D2 06/2019

Copyright © 2017 JET



Trick-Tools.com

75 Truman Road

Pella, IA 50219

Phone: 1-877-VAN-SANT

E-mail: sales@trick-tools.com





1.0 WARRANTY AND SERVICE

JET® warrants every product it sells against manufacturers' defects. If one of our tools needs service or repair, please contact Technical Service by calling 1-855-336-4032, 8AM to 5PM CST, Monday through Friday.

WARRANTY PERIOD

The general warranty lasts for the time period specified in the literature included with your product or on the official JET branded website, jettools.com.



WHO IS COVERED?

This warranty covers only the initial purchaser of the product from the date of delivery.

WHAT IS COVERED?

This warranty covers any defects in workmanship or materials subject to the limitations stated below. This warranty does not cover failures due directly or indirectly to misuse, abuse, negligence or accidents, normal wear-and-tear, improper repair, alterations or lack of maintenance.

HOW TO GET TECHNICAL SUPPORT

Please contact Technical Service by calling 1-855-336-4032. Please note that you will be asked to provide proof of initial purchase when calling. If a product requires further inspection, the Technical Service representative will explain and assist with any additional action needed. JET has Authorized Service Centers located throughout the United States. For the name of an Authorized Service Center in your area call 1-855-336-4032 or use the Service Center Locator on the JET website.

MORE INFORMATION

JET® is constantly adding new products. For complete, up-to-date product information, check with your local distributor or visit the JET website, jettools.com.

HOW STATE LAW APPLIES

This warranty gives you specific legal rights, subject to applicable state law.

LIMITATIONS ON THIS WARRANTY

JET LIMITS ALL IMPLIED WARRANTIES TO THE PERIOD OF THE LIMITED WARRANTY FOR EACH PRODUCT. EXCEPT AS STATED HEREIN, ANY IMPLIED WARRANTIES OF MERCHANTABILITY AND FITNESS FOR A PARTICULAR PURPOSE ARE EXCLUDED. SOME STATES DO NOT ALLOW LIMITATIONS ON HOW LONG AN IMPLIED WARRANTY LASTS, SO THE ABOVE LIMITATION MAY NOT APPLY TO YOU.

JET SHALL IN NO EVENT BE LIABLE FOR DEATH, INJURIES TO PERSONS OR PROPERTY, OR FOR INCIDENTAL, CONTINGENT, SPECIAL, OR CONSEQUENTIAL DAMAGES ARISING FROM THE USE OF OUR PRODUCTS. SOME STATES DO NOT ALLOW THE EXCLUSION OR LIMITATION OF INCIDENTAL OR CONSEQUENTIAL DAMAGES, SO THE ABOVE LIMITATION OR EXCLUSION MAY NOT APPLY TO YOU.

JET sells through distributors only. The specifications listed in JET printed materials and on official JET website are given as general information and are not binding. JET reserves the right to effect at any time, without prior notice, those alterations to parts, fittings, and accessory equipment which they may deem necessary for any reason whatsoever. JET® branded products are not sold in Canada by JPW Industries, Inc.

NOTE: JET is a division of JPW Industries, Inc. References in this document to JET also apply to JPW Industries, Inc., or any of its successors in interest to the JET brand.



2.0 TABLE OF CONTENTS

1.0 WARRANTY AND SERVICE	2
2.0 TABLE OF CONTENTS	4
3.0 SAFETY WARNINGS	5
4.0 INTRODUCTION	6
5.0 SPECIFICATIONS	6
6.0 UNPACKING	7
6.1 CONTENTS OF THE SHIPPING CONTAINER	7
7.0 SET-UP AND INSTALLATION	7
7.1 PREPARING THE MILLING MACHINE FOR SERVICE	7
8.0 ELECTRICAL CONNECTIONS	11
8.1 GENERAL ELECTRICAL CAUTIONS	11
8.2 WIRE SIZES	11
8.3 LUBRICATION	11
9.0 OPERATING INSTRUCTIONS	11
9.1 OPERATING CONTROLS	11
9.2 MOTOR SWITCH	11
9.3 SPEED CONTROL	13
9.4 SPINDLE BRAKE	13
9.5 HIGH-NEUTRAL-LOW SHIFT LEVER	13
9.6 QUILL POWER FEED LEVER	13
9.7 FEED RATE LEVER	14
9.8 FEED TRIP CAM LEVER	14
9.9 FEED DIRECTION CONTROL	15
9.10 COARSE FEED HANDLE	15
9.11 QUILL LOCK LEVER	15
9.12 MICROMETER ADJUSTING NUT	15
9.13 FINE FEED HANDWHEEL	15
9.14 DEPTH SCALE AND STOP	16
9.15 POWER FEED OPERATION	16
9.16 DRAW BAR OPERATION - CHANGING TOOLING	17
9.17 CLAMPING WORK PIECES TO THE TABLE	17
10.0 ADJUSTMENTS	17
10.1 MILL HEAD - LEFT/RIGHT ADJUSTMENT	17
10.2 MILL HEAD - FORE/AFT ADJUSTMENT	18
10.3 POSITIONING THE RAM	19
10.4 GIB ADJUSTMENT	20
10.5 POWER FEED TRIP LEVER MECHANISM	20
10.6 TABLE LEAD SCREW BACKLASH ADJUSTMENT	21
10.7 SPINDLE PIN (COLLET RETENTION)	22
11.0 MAINTENANCE	23
11.1 LUBRICATION	23
11.2 PERIODIC MAINTENANCE REQUIREMENTS	23
12.0 RECOMMENDED SPEED FOR MILL AND DRILL OPERATION	24
13.0 REPLACEMENT PARTS	24
14.0 WIRING DIAGRAM	48

3.0 SAFETY WARNINGS

1. Read and understand the entire owner's manual before attempting assembly or operation.
2. Read and understand the warnings posted on the machine and in this manual. Failure to comply with all of these warnings may cause serious injury. Replace the warning labels if they become obscured or removed.
3. This turret mill is designed and intended for use by properly trained and experienced personnel only. If you are not familiar with the proper and safe operation of a turret mill, do not use until proper training and knowledge have been obtained.
4. Do not use this turret mill for other than its intended use. If used for other purposes, JET®, disclaims any real or implied warranty and holds itself harmless from any injury that may result from that use.
5. Always wear approved safety glasses/face shields while using this turret mill. (Everyday eyeglasses only have impact resistant lenses; they are not safety glasses.)
6. Before operating this turret mill, remove tie, rings, watches and other jewelry, and roll sleeves up past the elbows. Remove all loose clothing and confine long hair. Non-slip footwear or anti-skid floor strips are recommended. Do not wear gloves.

7. Wear ear protectors (plugs or muffs) during extended periods of operation.
8. Do not operate this machine while tired or under the influence of drugs, alcohol or any medication.
9. Make certain the switch is in the OFF position before connecting the machine to the power supply.
10. Make certain the machine is properly grounded.
11. Make all machine adjustments or maintenance with the machine unplugged from the power source.
12. Remove adjusting keys and wrenches. Form a habit of checking to see that keys and adjusting wrenches are re-moved from the machine before turning it on.
13. Keep safety guards in place at all times when the machine is in use. If removed for maintenance purposes, use extreme caution and replace the guards immediately.
14. Some coolants used for machining contain chemicals that may be hazardous to your health if not used properly. Read and understand all information on the coolant container and protect yourself accordingly.
15. Check damaged parts. Before further use of the machine, a guard or other part that is damaged should be carefully checked to determine that it will operate properly and perform its intended function. Check for alignment of moving parts, binding of moving parts, breakage of parts, mounting and any other conditions that may affect its operation. A guard or other part that is damaged should be properly repaired or replaced.
16. Do not use power tools in damp/wet locations or other dangerous environments. Do not expose them to rain. Keep work area well lighted. Provide for adequate space surrounding work area and non-glare, overhead lighting.
17. Keep work area and the floor around the machine clean and free of scrap material, oil and grease.
18. Keep visitors a safe distance from the work area. Keep children away. Workshop should be childproof; padlocks, master switches, remove starter keys.
19. Give your work undivided attention. Looking around, carrying on a conversation and “horse-play” are careless acts that can result in serious injury.
20. Maintain a balanced stance at all times so that you do not fall or lean against the cutters or other moving parts. Do not overreach or use excessive force to perform any machine operation.
21. Use the right tool at the correct speed and feed rate. Do not force a tool or attachment to do a job for which it was not designed. The right tool will do the job better and more safely.
22. Use recommended accessories; improper accessories may be hazardous.
23. Maintain tools with care. Keep cutters sharp and clean for the best and safest performance. Follow instructions for lubricating and changing accessories.
24. Turn off the machine and disconnect from power before cleaning. Use a brush or compressed air to remove chips or debris — do not use your hands.
25. Do not stand on the machine. Serious injury could occur if the machine tips over.
26. Never leave the machine running unattended. Turn the power off and do not leave the machine until it comes to a complete stop.
27. Remove loose items and unnecessary work pieces from the area before starting the machine.
28. Clamp workpiece or brace against column to prevent rotation. For safety and use of both hands, use clamps or a vise to hold work when practical.
29. Use recommended speed for drill accessory and workpiece material.
30. Direction of feed — feed work into a blade or cutter against the direction of rotation of the blade or cutter only.
31. Installation work and electrical wiring must be done by qualified electrician in accordance with all applicable codes and standards.

 **WARNING:** This product can expose you to chemicals including lead which is known to the State of California to cause cancer and birth defects or other reproductive harm, and ethylbenzene which is known to the State of California to cause cancer. For more information go to <http://www.p65warnings.ca.gov>.

 **WARNING:** Some dust, fumes and gases created by power sanding, sawing, grinding, drilling, welding and other construction activities contain chemicals known to the State of California to cause cancer and birth defects or other reproductive harm. Some examples of these chemicals are:

- lead from lead based paint
- crystalline silica from bricks, cement and other masonry products
- arsenic and chromium from chemically treated lumber

Your risk of exposure varies, depending on how often you do this type of work. To reduce your exposure to these chemicals, work in a well-ventilated area and work with approved safety equipment, such as dust masks that are specifically designed to filter out microscopic particles. For more information go to <http://www.p65warnings.ca.gov/> and <http://www.p65warnings.ca.gov/wood>.



Familiarize yourself with the following safety notices used in this manual:

⚠ CAUTION

This means that if precautions are not heeded, it may result in minor injury and/or possible machine damage.

⚠ WARNING

This means that if precautions are not heeded, it may result in serious or even fatal injury.

4.0 INTRODUCTION

This manual is provided by JET® covering the safe operation and maintenance procedures for a JET Model ETM-949 and ETM-949EVS. This manual contains instructions on installation, safety precautions, general operating procedures, maintenance instructions and parts breakdown. Your machine has been designed and constructed to provide years of trouble-free operation if used in accordance with the instructions as set forth in this document.

If there are questions or comments, please contact your local supplier or JET. JET can also be reached at our web site: www.jettools.com. Retain this manual for future reference. If the machine transfers ownership, the manual should accompany it.

5.0 SPECIFICATIONS

Model Number	ETM-949, ETM-949EVS, ETM-949EVS-Type 2
Stock Number	894010, 894050,894050-1
Table Size (LxW) (in.)	9 x 49
Spindle Taper (in. x TPI)	R-8
Quill Diameter (in.)	3-3/8
Number of Spindle Speeds	Variable
Range of Spindle Speeds (RPM)	60-4500 / 60-5000
Quill Down Feed Rates (IPR)	.0015-.003-.006
Spindle Travel (in.)	5
Head Movement (deg.)	R90° & L45° F&B
Max Distance Spindle to Table (in.)	18-3/4
Distance Spindle to Column (max. in.)	21-2/5
Distance Spindle to Column (min. in.)	6
Collet Capacity	1/8-7/8
Table Longitudinal Travel (in.)	36
Table Cross Travel (in.)	12
T-Slots Number and Size (in.)	3 and 5/8
T-Slot Centers (in.)	2-1/2
Work Table Weight Capacity (lbs.)	750
Travel of Knee (in.)	16
Travel of Ram (in.)	14
Motor (HP)	3 HP, 230V 3Ph CSA/CUS Certified
Inverter	E type, 230V 3Ph
Overall Dimensions (LxWxH) (in.)	64 x 66 x 84
Net Weight (lbs.)	2420
Gross Weight (lbs.)	2420

The specifications in this manual were current at time of publication, but because of our policy of continuous improvement, JET, reserves the right to change specifications at any time and without prior notice, without incurring obligations.

6.0 UNPACKING

Open shipping container and check for shipping damage. Report any damage immediately to your distributor and shipping agent. Do not discard any shipping material until the Turret Mill is assembled and running properly.

Compare the contents of your container with the following parts list to make sure all parts are intact. Missing parts, if any, should be reported to your distributor. Read the instruction manual thoroughly for assembly, maintenance and safety instructions.

6.1 CONTENTS OF THE SHIPPING CONTAINER

Note: Some parts may be pre-installed on the mill.

- 1 Turret Mill (not shown)
- 1 Flat Way Cover
- 1 Pleated Way Cover
- 1 Draw Bar
- 3 Table Adjustment Handles
- 1 Tool Box, containing:
 - 1 Hex Key Set (1.5-10mm) *
 - 1 17/19mm Box Wrench *
 - 1 Cross Point Screw Driver #2 *
 - 1 Flat Blade Screw Driver #2 *
 - 1 Oil Can *
 - 1 Elevating Crank Handle
 - 1 Handwheel
 - 1 Coarse Feed Handle
 - 1 Can Silver Touch Up Paint
 - 1 Can Black Touch Up Paint
 - 1 Eye Bolt
 - 1 Operator's Manual (not shown)
 - 1 Warranty Card (not shown)

* parts with an asterisk are also included in the tool box service kit, p/n ETM-949/EVS.



Fig. 1

⚠ CAUTION

Read and understand the entire contents of this manual before attempting set-up or operation! Failure to comply may cause serious injury.

If your mill is supplied with an optional Table Powerfeed and/or DRO, be sure to consult the separate instruction materials that accompany them.

7.0 SET-UP AND INSTALLATION

7.1 PREPARING THE MILLING MACHINE FOR SERVICE

1. Remove any crating which may be covering the machine on the pallet.
2. Remove accessory items from the pallet or machine table. Compare these items with the list on the previous page.
3. Check the tightness of the lifting ring on the ram to be certain it is tight.
4. Check the tightness of the lock handles on the ram (see Figure 23) to be certain the ram is locked tight.
5. Remove the nuts and/or bolts, which secure the machine to the pallet.
6. Center an overhead crane or other suitable overhead lifting device and sling arrangement over the lifting ring.

Note: This machine weighs over 2400 pounds! Be certain the lifting arrangement is new or in excellent condition and has a safety factor that will account for age, difficulties in lifting, etc. When lifting using the ring, the machine will tip forward. If you wish, you can minimize this tipping by rigging a support sling over the front of the machine. Be careful when doing this, to prevent the sling from damaging any components on the front of the machine. Be sure to steady the mill to prevent it from spinning.

7. Lift the machine off the pallet no higher than necessary to clear the hold-down hardware, then pull the pallet out of the way. Do NOT get hands or feet underneath the machine when removing the pallet!
8. Put the machine base over the hold-down system where the machine will be spotted. Anchor bolts of sufficient size and length must be fastened to the floor according to the footprint of the mill. See diagram on page 9.



Note: The accompanying diagrams show you the maximum dimensions of the machines with the table, ram, etc., fully extended in all possible directions. When spotting the machine be certain to leave room not only for the machine itself, but also for operator clearance and clearance for workers servicing the machine, and any unusual sizes of workpieces that might extend off the machine's table.

9. When the machine is over its anchors, level the machine using shims under the corners needing them. The machinist's level used for leveling should be placed on the table. The table is the reference surface for both side-to-side and fore-and-aft leveling. Be certain you get it level in BOTH directions.

 **CAUTION**

Mill must be supported equally under all four corners. Failure to comply may cause the column to twist and put a bind in the table ways.

10. When the machine is level, secure the base to the anchor system.

IMPORTANT: Before attempting to raise the mill head, refer to Mill Head – Left/Right Adjustment in the Adjustments section for procedures to safely raise and set up the mill head.

11. Loosen the four hex head nuts (see A, Figure 20) about 1/4 turn each (counterclockwise), just enough to allow rotation of the head.
12. While assisting the worm mechanism by putting upward pressure on the motor by hand, use the wrench supplied with the machine to turn the worm nut and raise the head to upright position.
13. Tighten the headbolts slightly — not torqued — just snug.
14. Using mineral spirits or other cleaning solvent, clean all of the rust proofing from where it may have been applied. This is important; moving the table or any other components before removing the rust proofing will only put rust proofing where you don't want it.

Some of the following steps may have already been performed on the machine. If so, ignore the instructions related to those particular steps. Otherwise, perform them in the order listed, referring to Figure 9 for any clarification.

15. Install the table traverse and cross-feed cranks on their respective shafts using the nuts on the shafts to secure the cranks.
16. Remove any rust proofing from the drawbar and its washer, and put the drawbar with washer installed into the spindle center through the top of the machine.
17. Slide the fine feed handwheel over the handwheel hub and push it back until its rollpin engages the hole in the hub and the wheel is flush with the hub surface.
18. Put the coarse feed handle on the feed shaft and tap it lightly until its roll pin engages a hole in the hub and it is flush against the hub surface.
19. Unwrap and clean the knee crank and install it on its shaft.
20. Install the rubber way covers at front and behind the table.

ETM-949 DIMENSIONS

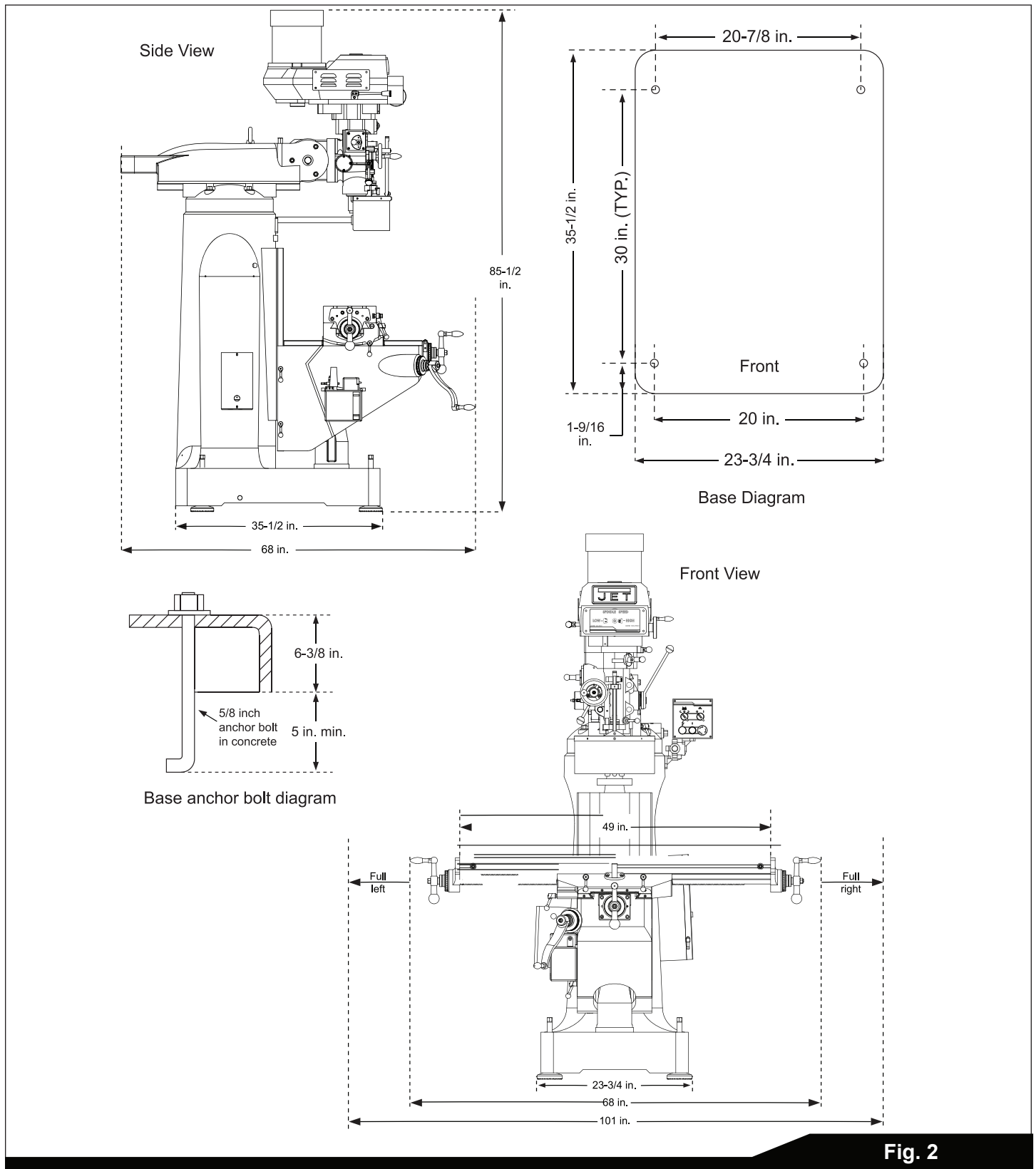

ETM-949 OVERVIEW AND TERMINOLOGY

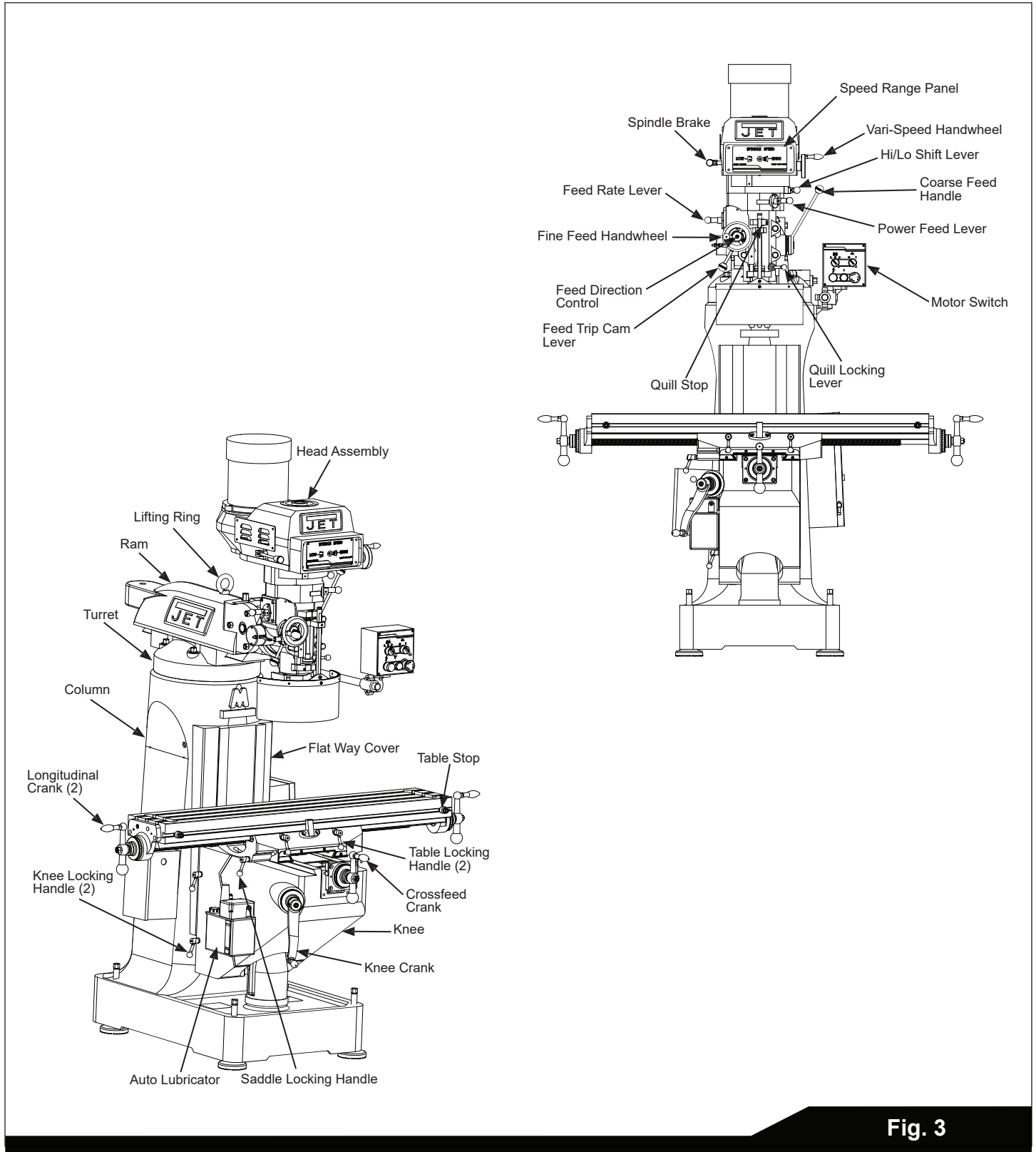

Fig. 3

8.0 ELECTRICAL CONNECTIONS

WARNING

All electrical connections must be made by a qualified electrician! Failure to comply may cause serious injury!

8.1 GENERAL ELECTRICAL CAUTIONS

This machine must be grounded in accordance with the National Electrical Code and local codes and ordinances. This work should be done by a qualified electrician. The machine must be grounded to protect the user from electrical shock.

8.2 WIRE SIZES

CAUTION

For circuits which are far away from the electrical service box, the wire size must be increased in order to deliver ample voltage to the motor.

To minimize power losses and to prevent motor overheating and burnout, the use of wire sizes for branch circuits or electrical extension cords according to the following table is recommended:

Conductor Length	AWG Number	
	230/460 Volt Lines	120 Volt Lines
0 – 50 Ft.	No. 14	No. 14
50 – 100 Ft.	No. 14	No. 12
Over 100 Ft.	No. 12	No. 8

Table 1

Confirm that power at the site matches power requirements of the mill before connecting to the power source. The ETM-949 has been pre-wired for 230 volt operation. Before connecting to the power source, make sure that the switch is in the off position.

The mill must be properly grounded.

Check for proper spindle rotation in the high-speed range. The spindle should rotate clockwise when viewed from the top of the machine. If the spindle rotates counter-clockwise, disconnect from power and switch two of the three power leads.

8.3 LUBRICATION

CAUTION

Do not operate the mill before lubricating the machine fully. Failure to comply may cause damage to the machine.

Refer to the Maintenance/Lubrication section and make sure the machine has been fully lubricated before operating.

9.0 OPERATING INSTRUCTIONS

9.1 Operating Controls

The milling machine is equipped with an automatic lubrication system. Ensure that reservoir has the proper amount of lubricant. The system reservoir is located on the left side of the machine on the knee.

The position of the milling machine mill head can be set up to accommodate the work piece being machined. The mill head can be set up for angles to the left or right and for fore and aft angles. The mill head can also be rotated on its turret. The ram can be moved back and forth to reach work piece locations at the fore and aft extremes of worktable travel. Refer to the Adjustments section.

9.2 Motor Switch

The Motor Switch is located on the right side of the machine on the control panel arm. The switch has two positions: FWD (forward) and REV (reverse).

Setting the switch to FWD will provide clockwise spindle rotation. Use FWD for normal, right-hand tooling.

FWD (clockwise) operation occurs only when the gearbox is in the low speed position. When the gearbox is in high-speed position, the motor switch must be in the REV position to provide right-hand or clockwise rotation. Refer to Figure 5 for a chart of required switch positions.

The motor switch controls a three-phase motor. The motor can be switched from FWD to REV and back with the motor running, and will reverse direction when the switch setting is changed. At higher speeds, this may put strain on the timing belt but there will be no damage to the motor or gear mechanism.

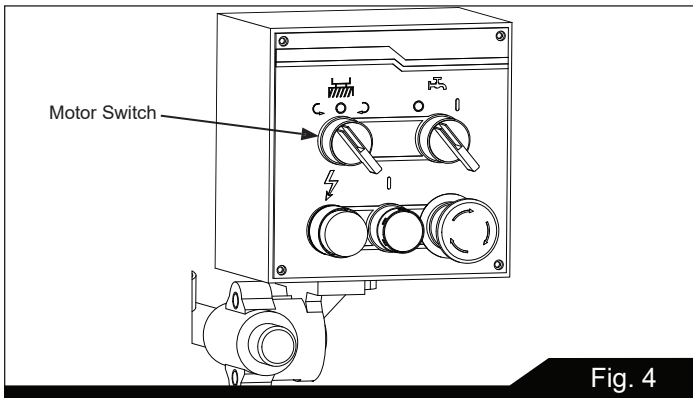

Fig. 4

Control Positions for Milling and Drilling Operations

Control	High/low lever	Quill feed lever	Feed trip cam lever	Quill feed select lever	Feed direction control	Motor switch*
Action	LO Neutral HI	En-gaged Disen-gaged	Engaged Disen-gaged		Out Middle In	FWD REV
High spindle speeds						REV
Low spindle speeds						FWD
High spindle speeds with automatic downfeed				Select feed rate		REV
Low spindle speeds with automatic downfeed				Select feed rate		FWD
High spindle speeds with automatic upfeed				Select feed rate		REV
Low spindle speeds with automatic upfeed				Select feed rate		FWD
Lever feed						
Fine feed using handwheel						
Free-turning spindle for positioning or working with tooling						

Speeds at Specific Control Settings

Hi/low speed control lever	Range of speeds using control wheel
	60 - 500 RPM
	500 - 4500 / 500 - 5000 RPM

*Motor switch position is right-hand tooling (tooling which requires clockwise rotation of the spindle.) If you are using left-hand tooling, simply change the motor switch to the opposite setting.

Fig. 5

9.3 SPEED CONTROL

9.3.1 VARIABLE SPEED CONTROL

⚠ CAUTION

Change speed only while the spindle is turning.

The vari-speed handwheel (A, Figure 6) is used to control the spindle speed. The speeds for high and low speed ranges are displayed on the panel on the front of the mill head (B, Figure 6).

All speed changes must be made while the motor is running. Attempting speed changes without the motor running can result in damage to the drive mechanism.

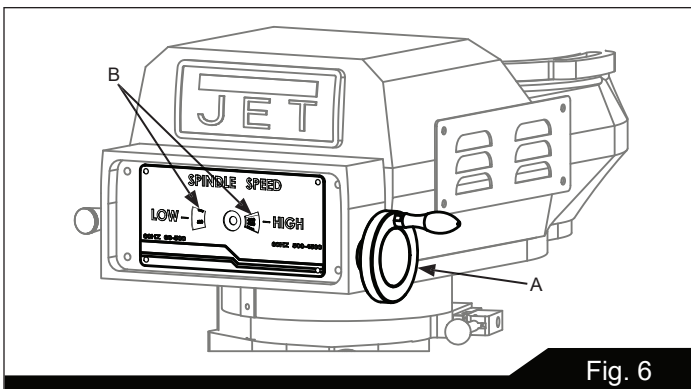

Fig. 6

9.3.2 ELECTRONIC VARIABLE SPEED

The dial on the EVS control panel controls the main motor speed. Motor rpm is displayed on the display screen. When in low gear, the light beside display 1 will be illuminated. When in high gear the light beside display 2 will be illuminated.

9.4 SPINDLE BRAKE

The spindle brake lever is located on the upper left side of the mill head (Figure 7). Pull lever downward to apply the brake. The spindle brake is also equipped with a power cut off microswitch. When the brake is applied, the power to motor is also disengaged.

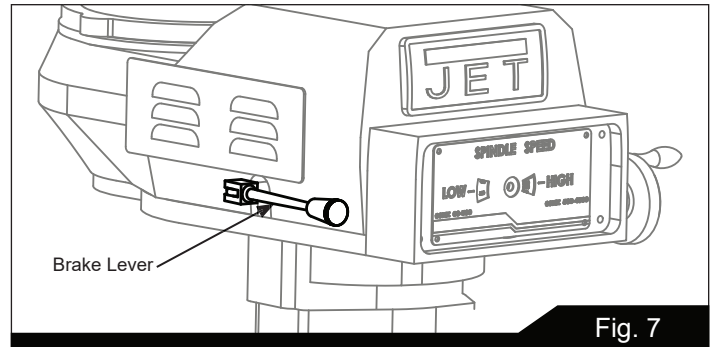

Fig. 7

9.5 HIGH-NEUTRAL-LOW SHIFT LEVER

The mill head can be driven directly (High Speed) or through the back gear (Low Speed) in the mill head. The selection is made by changing the position of the shift lever.

The shift lever is located at the lower right side of the mill head (Figure 8). The lever position closest to the operator is the High setting. The lever position away from the operator is the Low setting. The middle position is the Neutral setting.

⚠ CAUTION

Do not shift the High-Low Gear Lever while the motor is running. Rotate the spindle by hand to facilitate changing lever positions.

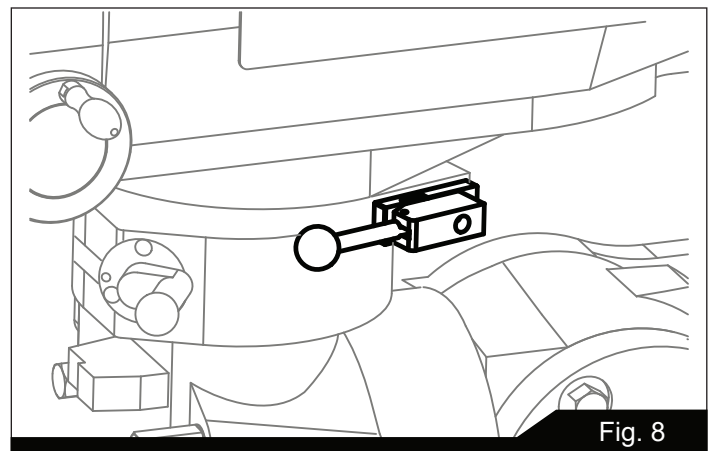

Fig. 8

9.6 QUILL POWER FEED LEVER

⚠ CAUTION

Do not use power feed at speeds above 3000 R.P.M.

⚠ CAUTION

It is recommended to disengage the power feed worm gear whenever the power feed is not required. This avoids unnecessary wear on the worm gear.

⚠ CAUTION

Do not move the Quill Power Feed Lever unless the motor is at a complete stop. When changing the lever position, do it gently. If the gear does not engage, jog the motor and allow it to stop before attempting to change.

The quill power feed lever is located on the right side of the mill head (Figure 9). It is used to engage and disengage the quill power feed mechanism.

The power feed is engaged by pulling out the knob and rotating the handle to a new locked position. When engaged, the power feed mechanism will drive the spindle upward or downward. The power feed mechanism will not drive the spindle when the handle is in the disengagement position.

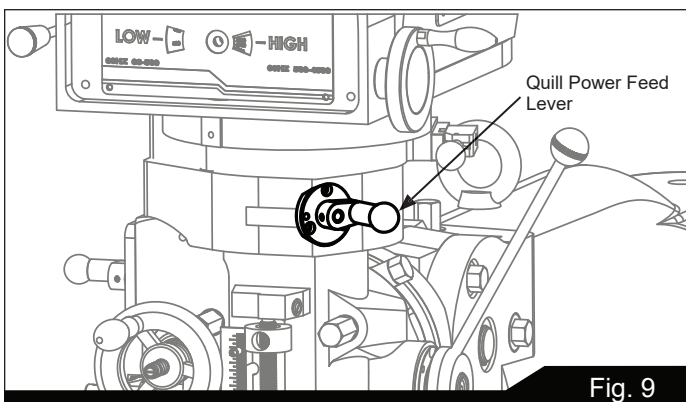

Fig. 9

9.7 FEED RATE LEVER

The Feed Rate Lever (Figure 10) is used to set the per-revolution rate of the power feed mechanism. Three feed rates are available: 0.0015-inch, 0.003-inch, and 0.006-inch per revolution. The positions are shown on an indicator plate under the feed rate lever.

The rate is selected by pulling out the knob on the feed rate lever and moving the handle to the detent of the desired feed rate.

Note: The knob is spring loaded – pull out to rotate to new position.

Unlike other controls on the machine, the lever shifts into engagement more easily with the motor running, and the quill feed lever engaged.

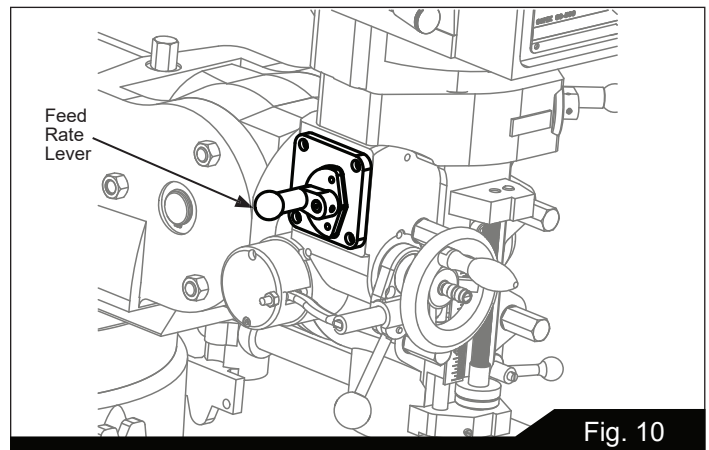

Fig. 10

9.8 FEED TRIP CAM LEVER

The Feed Trip Cam Lever (A, Figure 11) is located on the left side of the head behind the Manual Fine Feed Handwheel (B, Figure 11). It engages the overload clutch on the pinion shaft when positioned to the left. The Feed Trip Cam Lever stays engaged until Quill Stop (C, Figure 14) comes in contact with Micrometer Adjusting Nut (A, Figure 14) forcing it to drop out automatically, or until it is released manually by engaging the lever to the right.

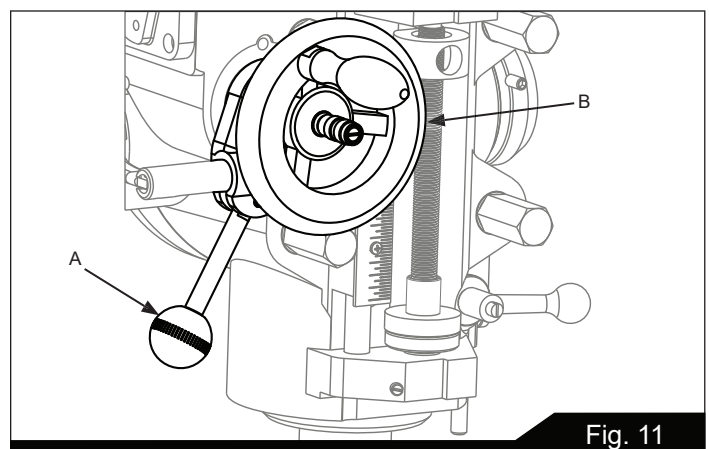

Fig. 11

9.9 FEED DIRECTION CONTROL

The Feed Direction Control (B, Figure 12) determines whether the power feed will move up, down, or not move at all. The position of the knob depends upon the direction of spindle rotation (see the Motor Switch section). The position of the control may be changed with the system stopped or running. If the control does not engage easily, move the fine feed handwheel (A, Figure 12) back and forth to aid engagement.

If the spindle is rotating clockwise, in is downfeed; out is upfeed. If the spindle rotation is counterclockwise, out is downfeed; in is upfeed. Neutral position is between the in and out position.

CAUTION

It is recommended that the Feed Direction Knob be left in the neutral position when not in use.

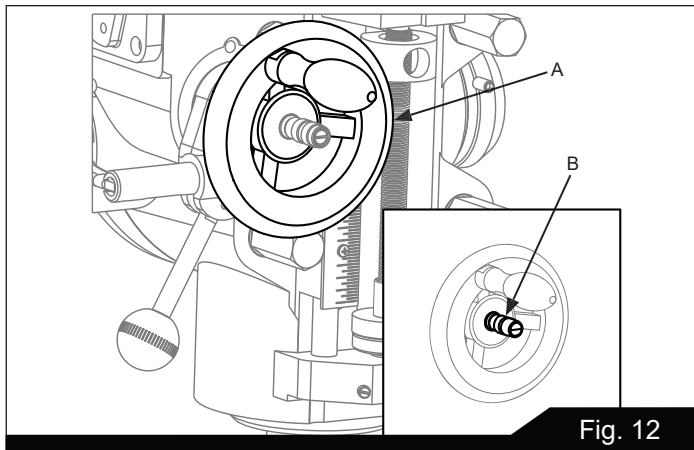

Fig. 12

9.10 COARSE FEED HANDLE

The Coarse Feed Handle (A, Figure 13) is located on the right side of head. The Coarse Feed Handle is used for non-precision drilling operations and for moving the quill to a specific depth. A return spring will retract the spindle automatically once the handle is released.

9.11 QUILL LOCK LEVER

The Quill Lock Lever (B, Figure 13) is located on the right side of the head. Rotate the handle clockwise to lock the quill in a desired position. Rotate the handle counter-clockwise to release.

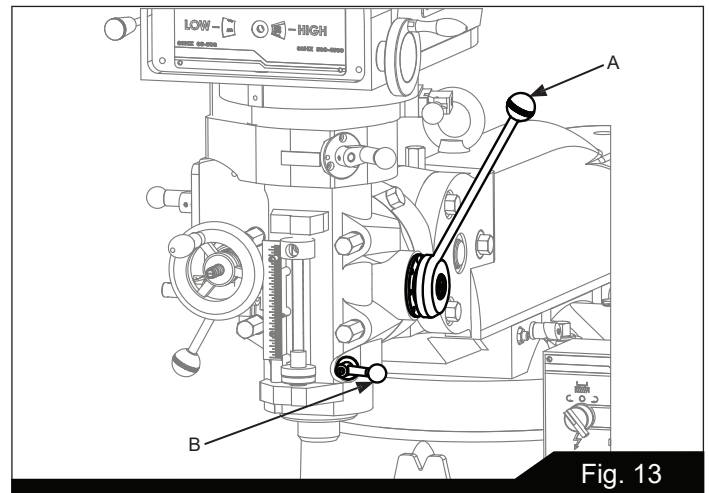

Fig. 13

9.12 MICROMETER ADJUSTING NUT

The Micrometer Adjusting Nut (A, Figure 14) is located on the front of the head. Use for setting specific spindle depth.

9.13 FINE FEED HANDWHEEL

When the controls are set for the Fine feed using Handwheel position (see Figure 5), the Fine Feed Handwheel (A, Figure 12) can be used for manual fine feed control in either upward or downward direction of the quill.

WARNING

Remove the Manual Fine Feed Handwheel when not in use. Failure to comply may cause serious injury.

9.14 DEPTH SCALE AND STOP

Referring to Figure 14:

The Depth Scale and Stop are used in drilling operations to set the depth of the drilled hole. The depth scale is located on the front of the mill head. The scale consists of a Micrometer Adjusting Nut (A), Micro-nut quick adjust (B), Quill Stop (C), Quill Stop Screw (D), and Scale (E).

The Micrometer Adjusting Nut is set to the desired dimension and is held in place by the friction applied by the micro-nut quick adjust. The quill stop provides a positive stop for quill travel.

The graduations on the micrometer nut are in 0.001 inch increments. Adjustment of quill travel is made by rotating the micrometer nut, or by pressing the micronut quick adjust button and sliding the nut up or down.

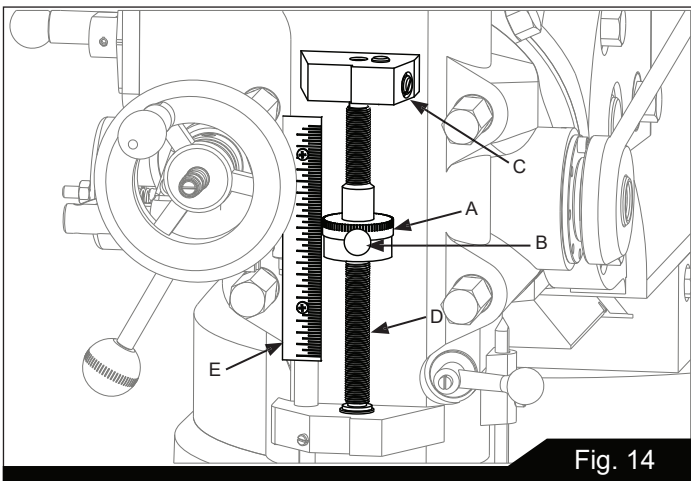

9.15 POWER FEED OPERATION

The Feed Trip Adjustment sets the point at which the quill will reset during Power Feed.

Referring to Figure 15:

WARNING

Be sure that the Manual Fine Feed Handwheel is removed. Failure to comply may cause serious injury.

1. Move adjuster nut to allow for ample spindle travel.
2. With the Quill Feed Handle (J), advance the quill to the point where the feed should stop.

3. Engage the Feed Trip Cam Lever (D) by pulling away from head assembly.
4. Adjust Micrometer Adjusting Nut (H) against Quill Stop (G).
5. Continue turning the Micrometer Adjusting Nut (H) until the Feed Trip Cam Lever (D) trips.
6. Ensure Quill Lock (K) is disengaged by rotating counterclockwise.
7. Start the spindle (See Fig. 5):
8. Select feed rate with the Variable Speed Control Handwheel (E).
9. Set the Feed Rate Lever (B) to the feed rate required for the tooling and material required.
10. Place the Quill Feed Engagement Lever (F) in the Engaged position.
11. Select feed direction by setting the Feed Direction Knob (C) position per the table:

Spindle Direction	Feed Direction	Knob Position
CW	Down	In
	Up	Out
CCW	Down	Out
	Up	In

Table 2

12. Engage the Feed Trip Cam Lever (D) by pulling away from head assembly.

Note: Due to variables in tool diameter, coatings, coolant, and materials, no specific spindle speed or feed rate recommendations are provided. Use general shop manuals that have data applicable to the milling and drilling operations being performed. Or, contact the supplier of the tooling, coolant, and material for specific recommendations.

IMPORTANT: The power feed can be used for drills up to 3/8" in diameter (mild steel). Use manual feed for drills larger than 3/8".

CAUTION

The overload clutch is factory set to hold up to 200 lbs. downfeed pressure on the quill (accommodates drills up to 3/8"). Do not attempt to adjust clutch pressure.

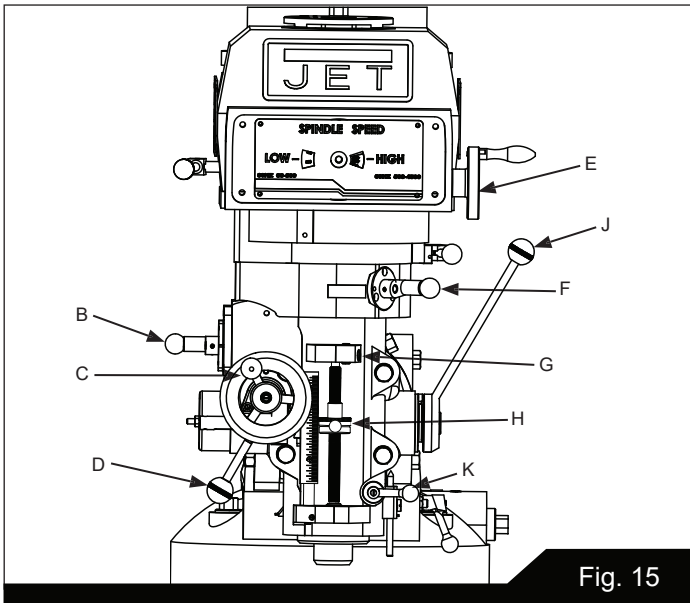

Fig. 15

9.16 DRAW BAR OPERATION - CHANGING TOOLING

1. Using the wrench provided with the machine, loosen the draw bar two or three turns (turn counterclockwise) using the draw bar hex (Figure 16).

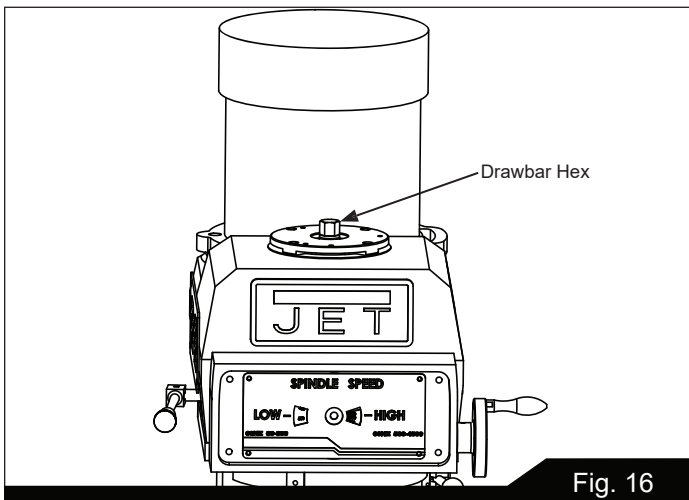

Fig. 16

2. Tap the top of the draw bar with a soft-faced hammer to loosen the collet from the taper.
3. Remove the tool from the collet.
4. Insert the tool you are going to use into the collet.
5. Tighten the draw bar firmly using the wrench provided with the machine. Turn the draw bar. The tool is now ready for use.

9.17 CLAMPING WORK PIECE TO THE TABLE

1. The worktable has 5/8-inch T-slots for clamping the work piece to the table.
2. Set motor switch to STOP position.
3. Place the work piece on the table.
4. Clamp the work piece using the T-slot clamps, studs, and step blocks as required (Figure 17).

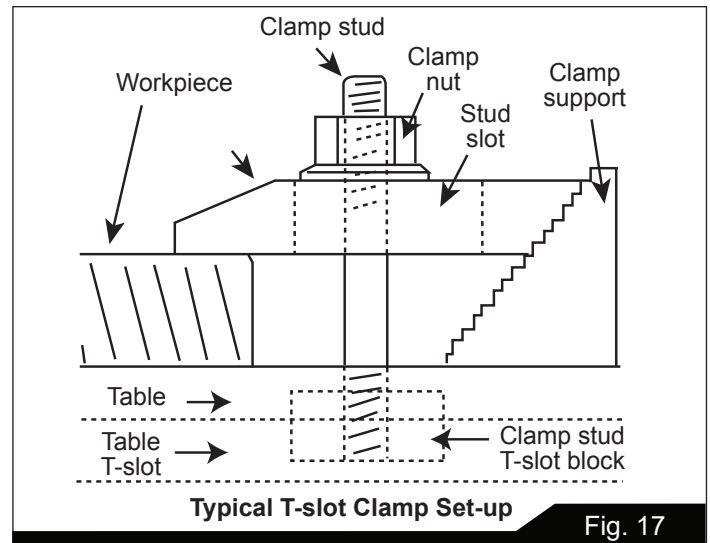

Fig. 17

10.0 ADJUSTMENTS

10.1 MILL HEAD – LEFT/RIGHT ADJUSTMENT

⚠ WARNING

Make sure the machine base is secured to the floor before repositioning the mill head. The center of gravity can shift enough to cause the machine to tip over, resulting in serious injury to the operator and damage to the machine.

1. Loosen four large hex nuts that secure the mill head to the ram adapter (refer to Figure 18).
1/4 turn should be sufficient to allow the head to move.

NOTE: For angles greater than 10 degrees, use your free hand to support the mill head, taking some weight off the brass worm gears. Doing so will greatly lengthen the life of the worm gears.

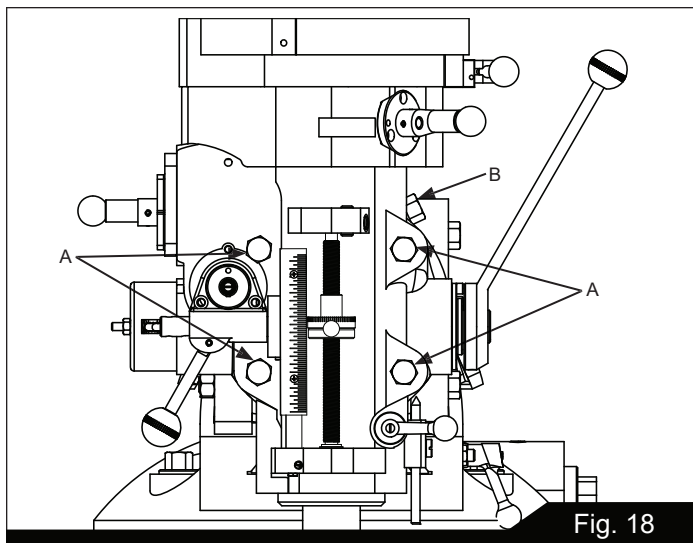

2. Turn the worm nut (B, Figure 18) to tilt the head left or right as required. Use the scale on the ram adapter to set the desired angle.

Note: The scales on the ram adapter and for head rotation are guides only. Close tolerance work will require the use of a dial indicator to make sure the head is 90° to the table in the X and Y axis. Please note the table is fitted to be slightly higher in front, usually about 0.0005”.

⚠ CAUTION

Be sure to apply torque in two steps using a crossing pattern. Failure to do so could distort the face of the ram adapter.

3. Tighten the four hex nuts. Tighten in two steps using a calibrated torque wrench. Use a crossing pattern to tighten the nuts. Tighten initially to 25 foot-pounds.
4. Before applying final torque, check to make sure the mill head is perpendicular to the worktable.
5. Set up a dial indicator in a collet and secure using the draw bar (refer to Figure 20).
6. Put the spindle drive in neutral.
7. Set the dial indicator plunger on the worktable. Zero the indicator.
8. Rotate the spindle 180 degrees (when rotating, raise the dial indicator plunger by hand to prevent it from dropping into the table T-slots).
9. Read the dial indicator. The indicator should read zero. If not, loosen the four hex nuts and reposition the mill head.

10. Recheck perpendicularity using the dial indicator. Repeat the procedure above until the dial indicator reads zero in both positions.

⚠ CAUTION

Be sure to apply torque in two steps using a crossing pattern. Failure to do so could distort the face of the ram adapter.

11. Tighten the four hex nuts. Tighten in two steps using a calibrated torque wrench. Use a crossing pattern to tighten the nuts. Tighten initially to 25 foot-pounds, then tighten to a final torque of 50 foot-pounds.

10.2 MILL HEAD – FORE/AFT ADJUSTMENT

1. Setting the angle:
 - a. Loosen the three ram adapter clamp bolts on the ram (A, Figure 19). There is no need to loosen the bolts more than 1/2 turn to allow tilting.

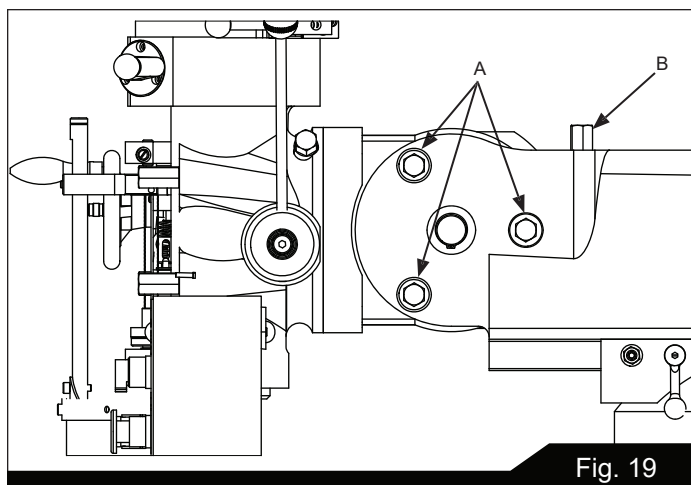

- b. Support the mill head with your free hand. Press upward on the spindle when changing the angle.
 - c. Turn the ram adapter worm nut (B, Figure 19) to tilt the head forward and backward. Use the scale on the ram adapter to locate the desired angle.
2. Returning to upright position:
 - a. When returning the mill head to its full upright position, be sure to support the head by upward pressure on the spindle as you turn the worm nut.
 - b. Check to make sure the mill head is perpendicular to the worktable.

c. Set up a dial indicator in a collet and secure using the draw bar (refer to Figure 20).

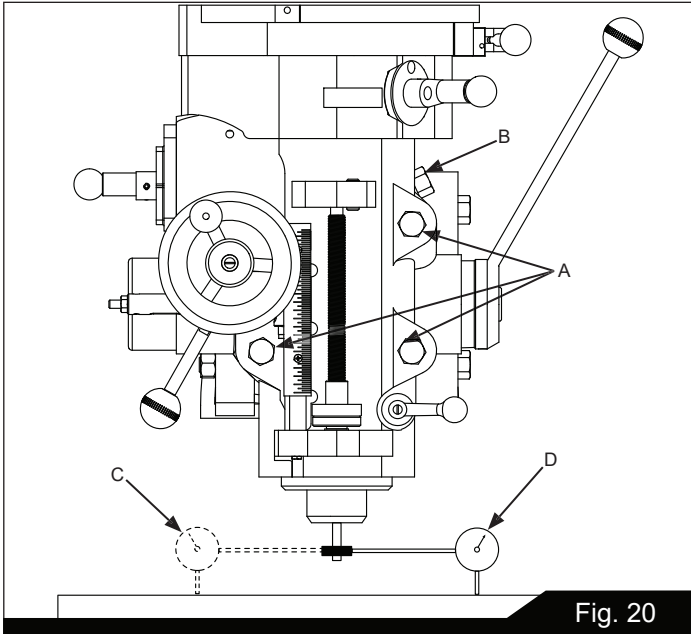

Fig. 20

- d. Put the spindle drive in neutral.
- e. Set the dial indicator plunger on the worktable. Zero the indicator.
- f. Rotate the spindle 180 degrees (when rotating, raise the dial indicator plunger by hand to prevent it from dropping into the table T-slots).
- g. Read the dial indicator. The indicator should read zero. If not, loosen the four hex nuts and reposition the mill head.
- h. Recheck perpendicularity using the dial indicator. Repeat the procedure above until the dial indicator reads zero in both positions.
- i. When the indicator reads zero, tighten the ram adapter clamp bolts.

10.3 POSITIONING THE RAM

Positioning the Ram Fore and Aft:

1. Loosen the two bolts (A, Figure 21) that lock the ram to its ways.
2. Turn the lever (B, Figure 21) to move the ram on its ways.
3. When the desired position is reached, lock the bolts (A, Figure 21) securely.

Positioning the Ram on its Turret:

⚠ WARNING

Make sure the machine base is secured to the floor before repositioning the ram. The center of gravity can shift enough to cause the machine to tip over, resulting in serious injury to the operator and damage to the machine.

1. Loosen four turret lock bolts (C, Figure 21) that clamp the ram to the top of the base. 1/2 turn should be sufficient to allow the turret to move.

Note: Use gentle hand pressure to avoid rapid movement.

2. Turn the ram until the spindle is in the desired position. Use the scale on the turret for degree measurement.
3. Tighten the four turret lock bolts (C, Figure 21).

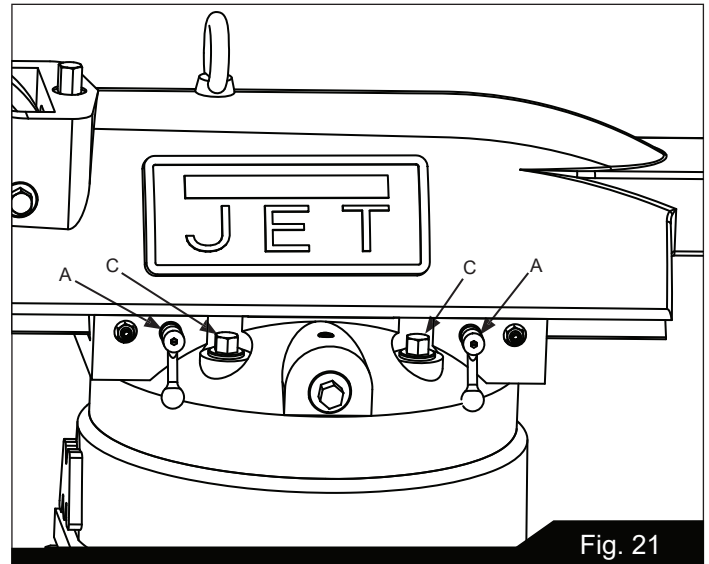

Fig. 21

10.4 GIB ADJUSTMENT

The table, saddle and knee are equipped with adjustable gibs. The gibs may require adjustment if unusual vibration is noted when the locking mechanisms are off, or if you experience unusual vibration when spindle speed, tooth pitch or depth of cut do not account for the vibration.

NOTE: When adjusting gibs, always start with the knee first; adjust the saddle second, and adjust the table last.

Adjustment of Knee Gib:

The knee gib adjustment screw (A, Figure 22) is located under the chip wiper at the rear of the knee where it contacts the column. Remove the way cover and the wiper to expose the gib adjustment screw. Tighten the screw until a slight drag is felt when turning the knee crank.

Adjustment of Saddle Gib:

The saddle gib adjustment screw is on the left front of the saddle (B, Figure 22). Tighten the screw until a slight drag is felt when turning the cross-feed crank.

Adjustment of Table Gib:

The table gib adjustment screw (C, Figure 22) is on the left-hand side, beneath the table. Tighten the screw until a slight drag is felt when turning the longitudinal table cranks.

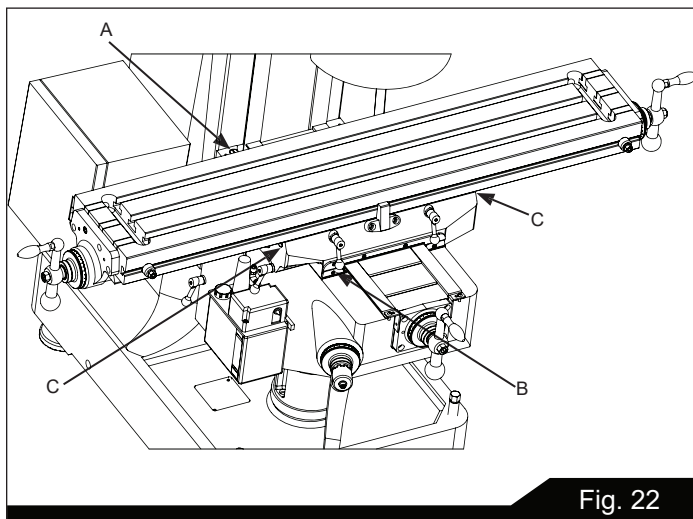

Fig. 22

10.5 POWER FEED TRIP LEVER MECHANISM

Refer to Figure 23.

The power feed trip lever mechanism will need to be adjusted if worn or whenever any trip lever mechanism components are replaced.

1. Loosen the feed trip adjusting screw lock nut.
2. Loosen the adjusting screw until it is loose in the lever and no longer contacts the bottom of the feed trip plunger.
3. Using the coarse feed handle, move the quill to the bottom of its travel so the quill stop contacts the micrometer nut. Hold the quill on the stop.
4. Pull the feed handle out to engage the power feed system.
5. Turn the feed trip adjusting screw until the power feed disengages.
6. Tighten the feed trip adjusting screw.
7. Release the quill stop so you can engage the power feed mechanism using the power feed trip lever.
8. Using the coarse feed handle, pull the quill stop back into firm contact with the micrometer nut.

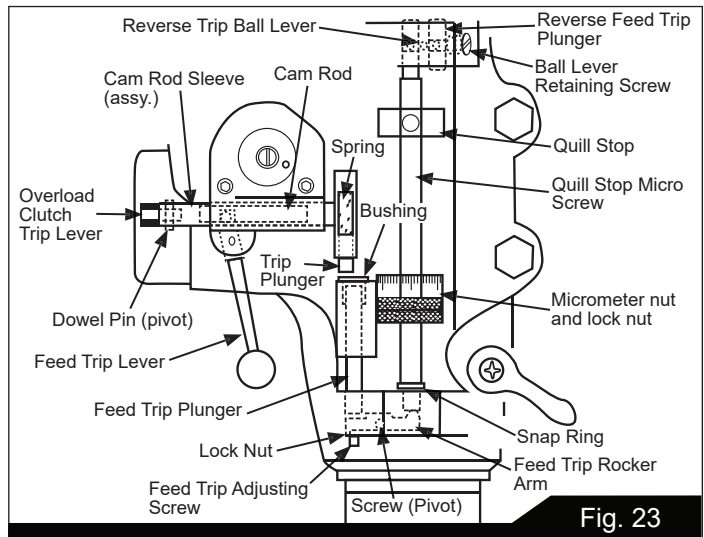

Fig. 23

Note: The power feed should disengage when the quill stop pushes on the micrometer nut. If it does not disengage, repeat the adjustment steps above.

9. Engage the power feed and move the quill stop to the top of its travel. Make sure that the reverse trip mechanism also disengages the power feed. If not, readjust the mechanism until positive disengagement occurs when the quill is at the top of its stroke.

10. Check for correct operation using the coarse feed handle. If operating correctly, start the drive motor and engage the power feed mechanism. Verify that the power feed lever correctly engages and disengages when driven by the drive motor.

10.6 TABLE LEAD SCREW BACKLASH ADJUSTMENT

Refer to Figure 24.

The milling machine table is moved by a lead screw and nut for each machine axis. For proper operation, there must be clearance between the lead screw and the nut, which results in backlash. A second lead screw nut is provided to eliminate most of the backlash. The following procedures provide instructions for obtaining acceptable backlash.

Cross Feed Backlash Adjustment:

1. Use the cross feed crank to move the table to the extreme rear of its travel.
2. Remove the pleated way cover.
3. Open the two chip guards enough to expose the cross-feed adjustment nut (the nut that is toward the rear of the nut bracket is not adjustable – only the front nut is adjustable).
4. Loosen the two nut locking screws.
5. Turn the nut slightly to tighten it against the opposing nut.

6. Tighten the two nut locking screws.
7. Using the cross-feed crank, move the table to the middle position.
8. Set up a dial indicator to check cross-feed backlash. Gently move the cross feed crank back and forth while watching the dial indicator. Backlash should be between 0.003 inch and 0.005 inch.
9. If necessary, repeat the steps above to set backlash.
10. Install the pleated way cover.

Longitudinal Backlash Adjustment:

Refer to Figure 24.

1. Only one of the longitudinal lead screw nuts can be adjusted. The other nut is fixed. The left hand nut is typically adjustable. This can be determined by looking at the nut from the underside of the table.
2. Loosen the two nut locking screws.
3. Turn the nut slightly to tighten it against the opposing nut.
4. Tighten the two nut locking screws.
5. Using the longitudinal table crank, move the table to the middle position.
6. Set up a dial indicator to check longitudinal backlash. Gently move the crank back and forth while watching the dial indicator. The backlash should be between 0.003 inch and 0.005 inch.

If necessary, repeat the steps above to set backlash.

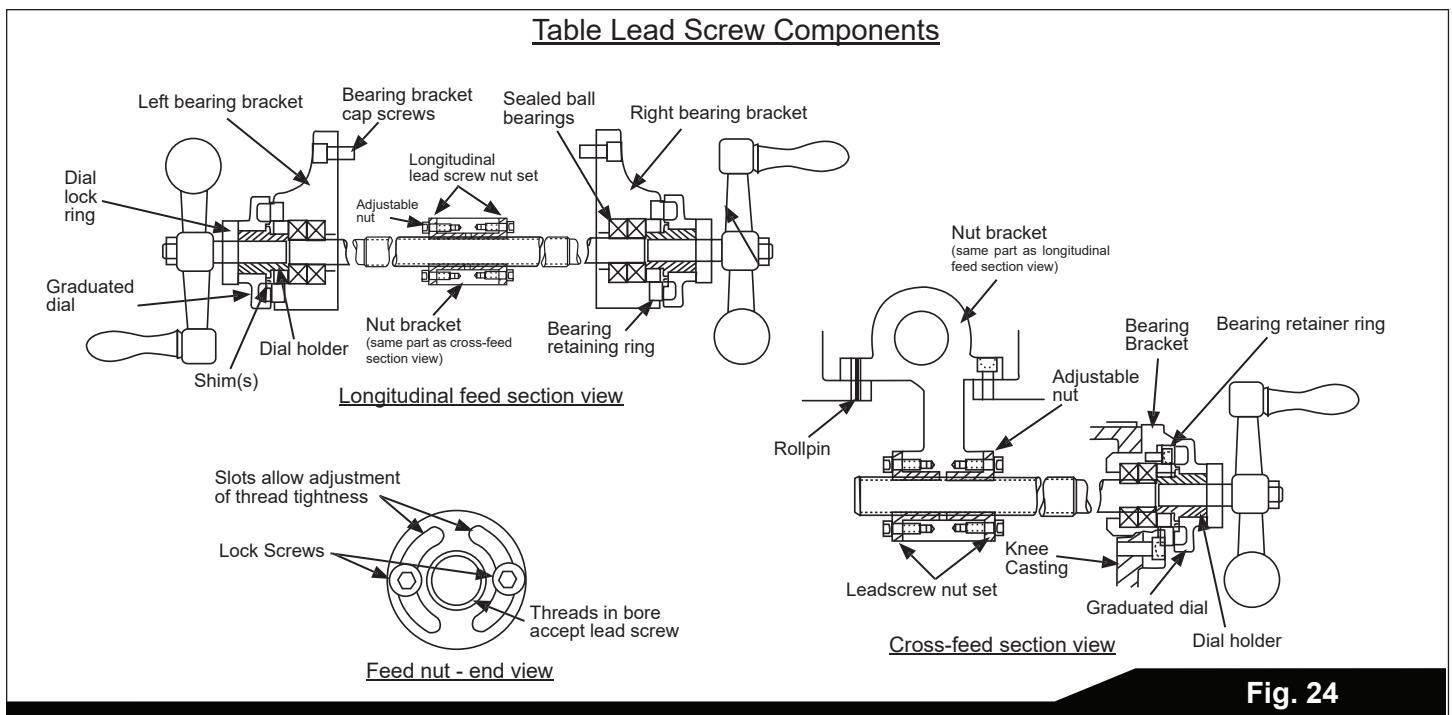

Fig. 24

10.7 SPINDLE PIN (COLLET RETENTION)

A spindle pin (set screw) protrudes into the interior of the spindle to prevent a collet from rotating inside the spindle. It has been set by the manufacturer to protrude 1.6mm beyond the interior spindle wall. However, collets may have varied groove depths. If this pin needs adjustment:

1. Remove set screw at rear of quill with 2.5mm hex key. See Figure 25.
2. Unscrew end cap from quill. (NOTE: Left hand thread – clockwise to remove). See Figure 26.
3. Adjust spindle pin to desired depth with 3mm hex key. See Figure 27.
4. Insert collet to confirm the fit.
5. When satisfied, reinstall end cap and rear set screw.



Fig. 25

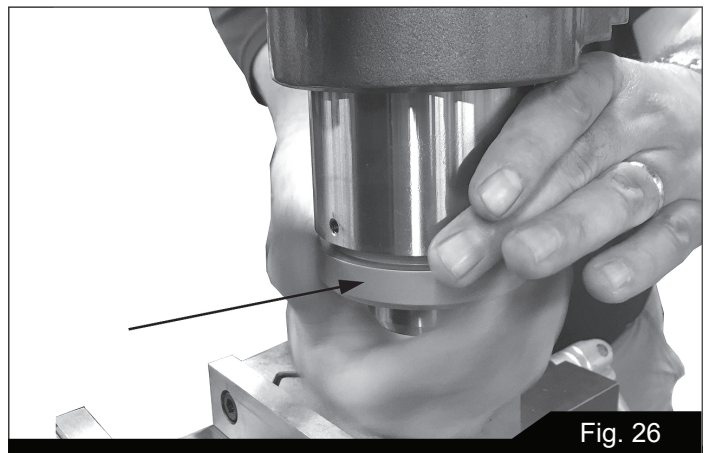

Fig. 26

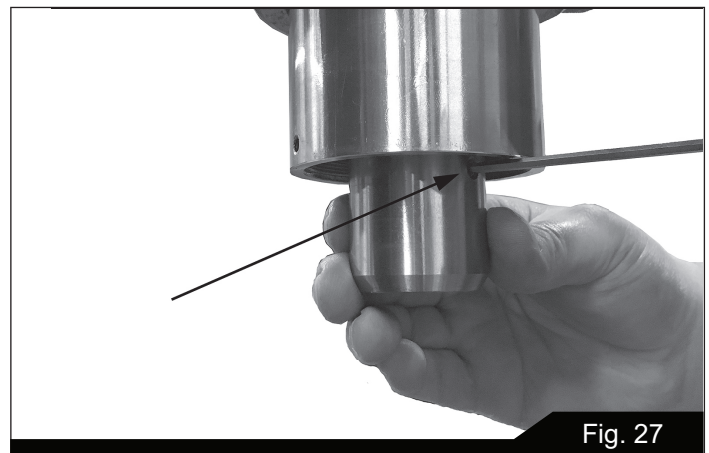

Fig. 27

11.0 MAINTENANCE

WARNING

Before any intervention on the machine, disconnect it from the electrical supply by pulling out the plug or switching off the main switch! Failure to comply may cause serious injury.

11.1 LUBRICATION

The milling machine is equipped with a “auto lube” lubrication system. The system lubricates the lead screws and ways. An oil cup and grease nipple on the mill head provide lubrication for the spindle bearings and back gear mechanism. Refer to Figures 28 and 29 for lubrication requirements and access points.

Key	Description	Recommended Lubricant	Action
A	Spindle bearing oil cup	Mobil DTE Oil Light, or equivalent	Service daily.
B	Auto Lube	Mobil Vactra Oil #2, or equivalent	Check oil daily – add if required. Pull lube handle every hour during operations.
C	Knee leadscrew grease nipple	Mobilith AW2, or equivalent	Service once each week.
D	Back gear grease nipple	Mobilith AW1, or equivalent	Service weekly when operating in back gear mode.

Table 2

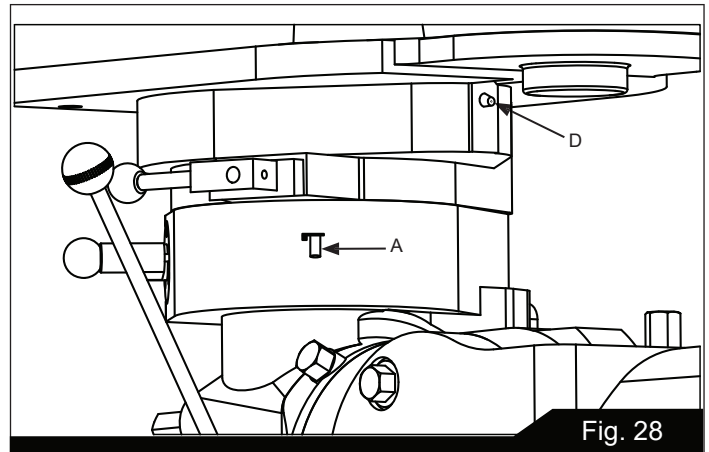

Fig. 28

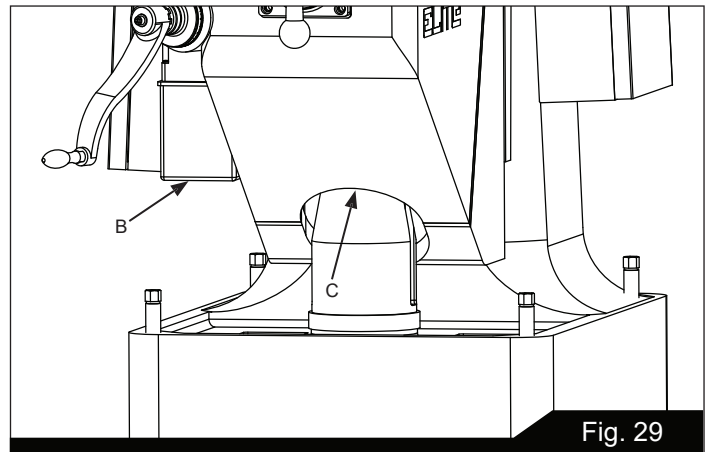

Fig. 29

11.2 PERIODIC MAINTENANCE REQUIREMENTS

During operation, periodically vacuum and brush chips and debris from machine.

Periodically operate knee and table lead screws through full range of movement to evenly distribute lubricant.

Periodically apply light machine oil to work table and other exposed metal surfaces to prevent rust or corrosion.

Periodically remove vent panels to check pulleys and belts for unusual wear or grooving.

NOTE: Operators should vary speed occasionally to prevent formation of grooves on the pulley surfaces.



12.0 RECOMMENDED SPEED FOR MILL AND DRILL OPERATION

Mill cutting speed recommended (mm/min)
 $V=DN/1000$

Material	V cutting speed (m/ min)	
	Heavy Cutting	Processing Cutting
Cast iron	30-40	45-90
Malleable iron	37-45	45-90
Steel (Soft)	60-90	75-105
Steel (Medium)	45-67	52-75
Steel (Hard)	24-37	55-75
Cast Steel	24-30	55-75
Alluminum	240-300	300-360
Brass	105-180	150-300
Bronze	52-75	75-90
Magnesium Alloy	240-300	300-600
Zinc Alloy	120-240	210-450

Drill speed (RPM) recommend

5mm hole	1000-1500
10mm hole	500-800
13mm	300-500
20mm	150-300

13.0 REPLACEMENT PARTS — ETM-949, ETM-949EVS

Replacement parts are listed on the following pages. To order parts or reach our service department, call 1-800-274-6848 Monday through Friday, 8:00 a.m. to 5:00 p.m. CST. Having the Model Number and Serial Number of your machine available when you call will allow us to serve you quickly and accurately.

Non-proprietary parts, such as fasteners, can be found at local hardware stores, or may be ordered from JET.

Some parts are shown for reference only, and may not be available individually.

JET®
427 New Sanford Road
LaVergne, Tennessee 37086
www.jettools.com
Phone: 855-336-4032

TABLE ASSEMBLY — ETM-949, ETM-949EVS

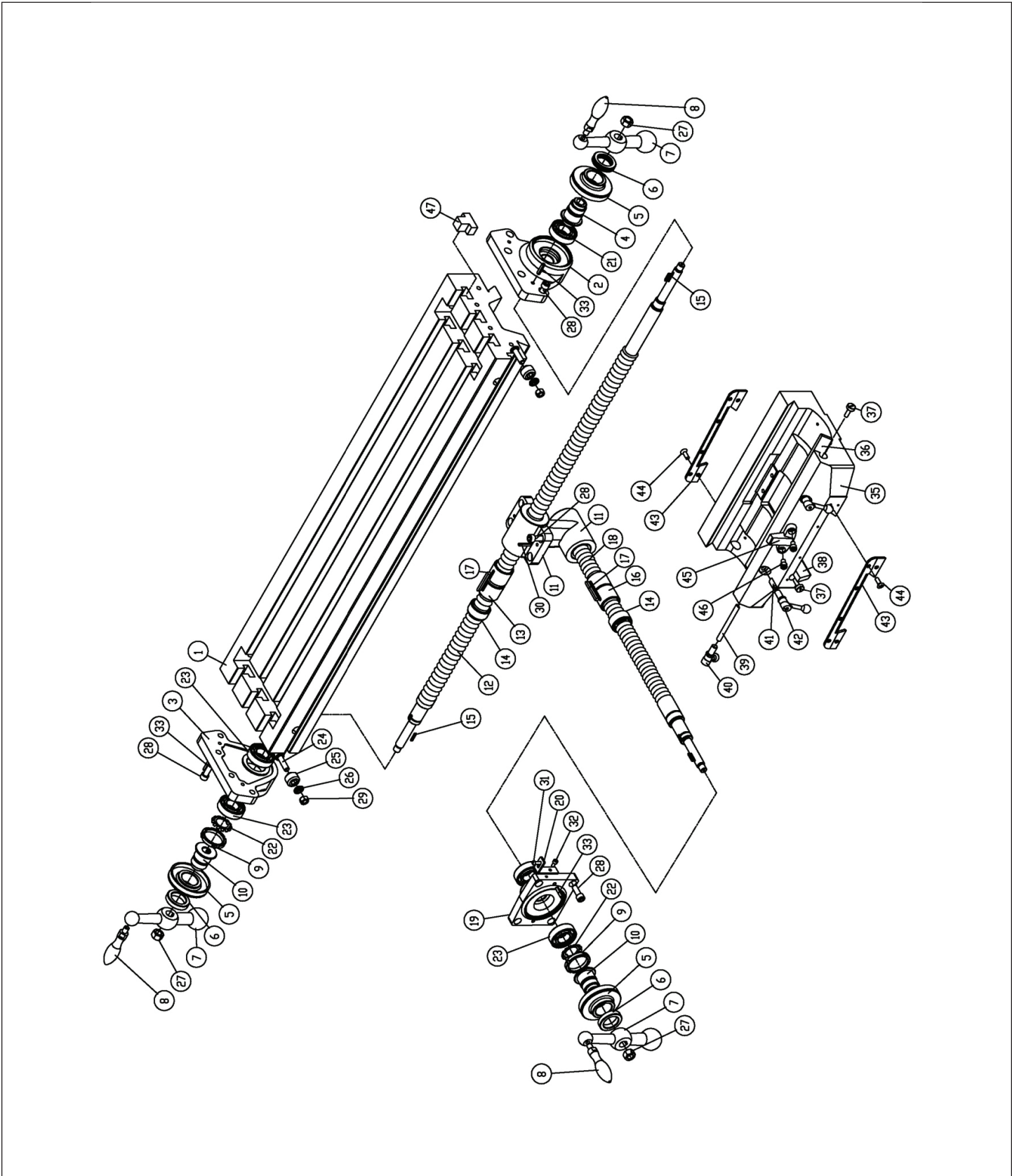
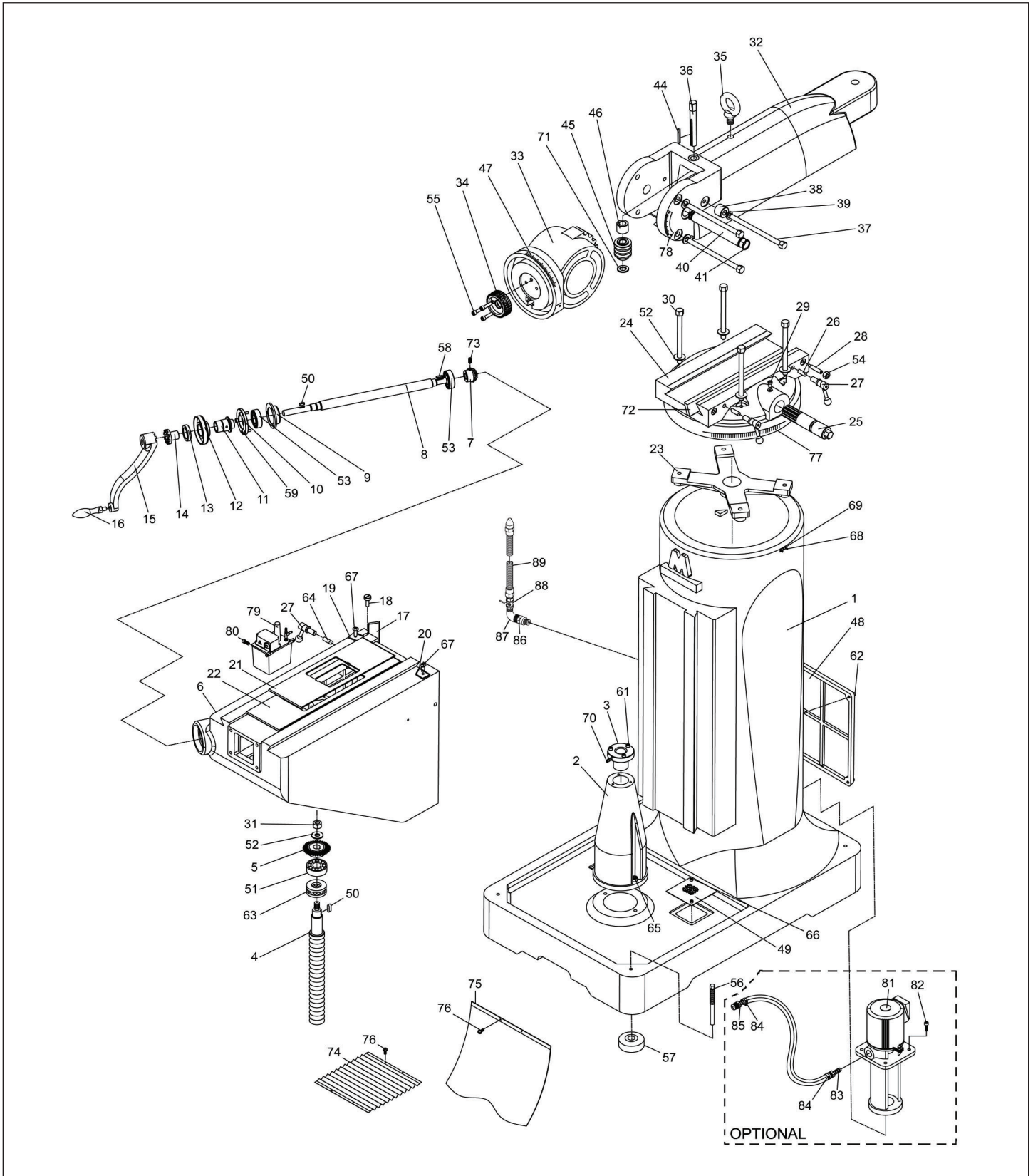



TABLE ASSEMBLY PARTS LIST

Index No.	Part No.	Description	Size	Qty.
1	ETM949-A01	Table	9"×49"	1
2	ETM949-A02	Left Bearing Bracket		1
3	ETM949-A03	Right Bearing Bracket		1
4	ETM949-A04	Dial Holder		1
5	ETM949-A05	Inch Dial	inch	3
6	ETM949-A06	Dial Nut		1
7	ETM949-A07	Ball Crank Handle		3
8	ETM949-A08	Ball Crank Handle Lever	3/8"-16UNC	3
9	ETM949-A09	Lock Nut		2
10	ETM949-A10	Dial Holder		2
11	ETM949-A11	Feed Nut Bracket		1
12	ETM949-A12	Longitudinal Feed Screw	49"	1
13	ETM949-A13	Longitudinal Feed Nut (inch)		2
14	ETM949-A14	Backlash Adjustment Nut	inch	2
15	ETM949-A15	Flat Key	3×3×20	3
16	ETM949-A16	Cross Feed Screw Nut (inch)		2
17	ETM949-A17	Flat Key	5×5×50	2
18	ETM949-A18	Cross Feed Screw (inch)		1
19	ETM949-A19	Cross Feed Bearing Bracket		1
20	ETM949-A20	Front Rubber Chip Cover Shaft Bracket		2
21	BB-6204	Bearing	6204	1
22	ETM949-A22	Lock Washer	AW04	2
23	BB-51105	Bearing	51105	4
24	ETM949-A24	Stop Piece T-Bolt		2
25	ETM949-A25	Table Stop Piece		2
26	ETM949-A26	Washer		2
27	TS-0561031	Nut	3/8"	3
28	ETM949-A28	Bolt	3/8"×1"	16
29	TS-0561031	Nut	3/8"	2
30	ETM949-A30	Overload Clutch Lever Spring Plunger	5×30	2
31	ETM949-A31	Cross-Recessed Head Screw	3/16"× 5/8"	2
32	TS-1502021	Bolt	M5×10	2
33	ETM949-A33	Overload Clutch Lever Spring Plunger	6×25	6
35	ETM949-A35	Saddle	49"	1
36	ETM949-A36	Saddle Knee Gib		1
37	ETM949-A37	Adjusting Screw		3
38	ETM949-A38	Saddle Table Gib		1
39	ETM949-A39	Saddle Lock Plunger		1
40	ETM949-A40	Table Lock Bolt Handle	1/2"-12UNC	1
41	ETM949-A41	Adaptor Pivot Stud Locknut		1
42	ETM949-A42	Table Lock Bolt Handle	1/2"-12UNC	2
43	ETM949-A43	Felt Wipers		1
44	ETM949-A44	Cross-Recessed Head Screw	3/16 ×15	8
45	ETM949-A45	Table Stop Bracket		1
46	TS-0209051	Hex-Socket Head Cap Screw	3-8×15	2

BASE ASSEMBLY — ETM-949, ETM-949EVS





BASE ASSEMBLY PARTS LIST

Index No.	Part No.	Description	Size	Qty.
1	ETM949-B01	Body		1
2	ETM949-B02	Elevating Screw Housing		1
3	ETM949-B03	Elevating Screw Nut(Inch)		1
4	ETM949-B04	Elevating Screw (Inch)		1
5	ETM949-B05	Bevel Gear (Big)		1
6	ETM949-B06	Knee		1
7	ETM949-B07	Bevel Gear(Small)		1
8	ETM949-B08	Elevating Shaft		1
9	ETM949-B09	Bearing Housing		1
10	ETM949-B10	Bearing Cap		1
11	ETM949-B11	Dial Holder		1
12	ETM949-B12	Inch Dial		1
13	ETM949-B13	Dial Nut		1
14	ETM949-B14	Gear Shaft Clutch Insert		1
15	ETM949-B15	Elevating Crank		1
16	ETM949-B16	Ball Crank Handle Lever	3/8"-16UNC	1
17	ETM949-B17	Knee Column Gib		1
18	ETM949-B18	Adjusting Screw		2
19	ETM949-B19	Felt Wipers		1
20	ETM949-B20	Felt Wipers		1
21	ETM949-B21	Chip Guards (Down)		1
22	ETM949-B22	Chip Guards (Up)		1
23	ETM949-B23	Spider		1
24	ETM949-B24	Turret		1
25	ETM949-B25	Ram Pinion		1
26	ETM949-B26	Ram Lock Plunger		2
27	ETM949-B27	Table Lock Bolt Handle (Include C038) 1/2"-12UNC		3
28	ETM949-B28	Gib Lock Screw		1
29	ETM949-B29	Ram Pinion Set		1
30	ETM949-B30	Locking Bolt		4
31	TS-0561051	Nut	1/2"	1
32	ETM949-B32	Ram		1
33	ETM949-B33	Ram Adaptor		1
34	ETM949-B34	Quill Housing Adjusting Gear		1
35	ETM949-B35	Hook		1
36	ETM949-B36	Vertical Adjusting Worm Shaft		1
37	ETM949-B37	Adaptor Locking Bolt	185mm	3
38	ETM949-B38	Adaptor Pivot Stud Locknut		1
39	TS-155009	Washer	M14	1
40	ETM949-B40	Adaptor Pivot Stud		1
41	ETM949-B41	Snap Ring C-Type	S-26	2
42	TS-155009	Washer	M14	1
43	TS-155009	Washer	M14	1
44	ETM949-B44	Flat Key	5×5×50	1
45	ETM949-B45	Vertical Adjusting Worm		1

Index No.	Part No.	Description	Size	Qty.
46	ETM949-B46	Worm Thrust Washer		1
47	ETM949-B47	Adaptor Scale		1
48	ETM949-B48	Back Cover		2
49	ETM949-B49	Filter Oil Net		2
50	ETM949-B50	Flat Key	5×5×15	2
51	BB-6205	Bearing	6205	1
52	ETM949-B52	Washer		4
53	BB-6204	Bearing	6204	2
54	TS-0561031	Nut	3/8"	1
55	TS-1504051	Hex-Socket Head Cap Screw	M8 × 25	3
56	ETM949-B56	Level Screw And Nut		4
57	ETM949-B57	Leveling Pads		4
58	ETM949-B58	Flat Key	4×4×20	1
59	TS-1503051	Hex-Socket Head Cap Screw	M6 × 20	3
60	TS-1503051	Hex-Socket Head Cap Screw	M6 × 20	1
61	TS-1503051	Hex-Socket Head Cap Screw	M6 × 20	2
62	TS-1503041	Hex-Socket Head Cap Screw	M6× 15	8
63	ETM949-B63	Bearing	51305	1
64	ETM949-B64	Knee Lock Plunger		1
65	TS-1505021	Hex-Socket Head Cap Screw	M10 × 20	2
66	TS-1502021	Hex-Socket Head Cap Screw	M5 × 10	4
67	TS-1503031	Cross-Recessed Head Screw	M6 ×12	2
68	ETM949-B68	Rivet Nut	M2×5	4
69	ETM949-B69	Zeroing Point Plate		1
70	ETM949-B70	Nozzle	1/8PT	1
71	ETM949-B71	Washer		1
72	ETM949-B72	Turret-Ram Gib		1
73	TS-1534032	Set Screw	M6×10	1
74	ETM949-B74	Rubber Chip Cover (Front, Wave)		1
75	ETM949-B75	Rubber Chip Cover (Rear, Flat)		1
76	TS-1534041	Cross-Recessed Head Screw	M5×10	8
77	ETM949-B77	Turret Scale		1
78	ETM949-B78	Angle Plate		1
79	ETM949-B79	Auto Lubricator		1
80	TS-1534041	Cross-Recessed Head Screw	M5×10	4
81	ETM949-B81	Coolant Pump 150L * RE: 894092		1
82	TS-1503051	Hex-Socket Head Cap Screw*	M6× 20	4
83	ETM949-B83	Water Pipe Adapter* RE: 894092	3/8PT×3/8HS	1
84	ETM949-B84	Restraint* RE: 894092	5/8"	2
85	ETM949-B85	Water Pipe Adapter* RE: 894092	1/2PT×1/2HS	1
86	ETM949-B86	Insert Connect	3/8PT×7/8HS	1
87	ETM949-B87	High Pressure Connect L-Type	3/8PT×3/8PT	1
88	ETM949-B88	Switch	3/8"	1
89	ETM949-B89	Flexible Steel Coolant Hose	30"	1

* optional accessory - order 894092 Coolant System

HEAD ASSEMBLY — ETM-949, ETM-949EVS

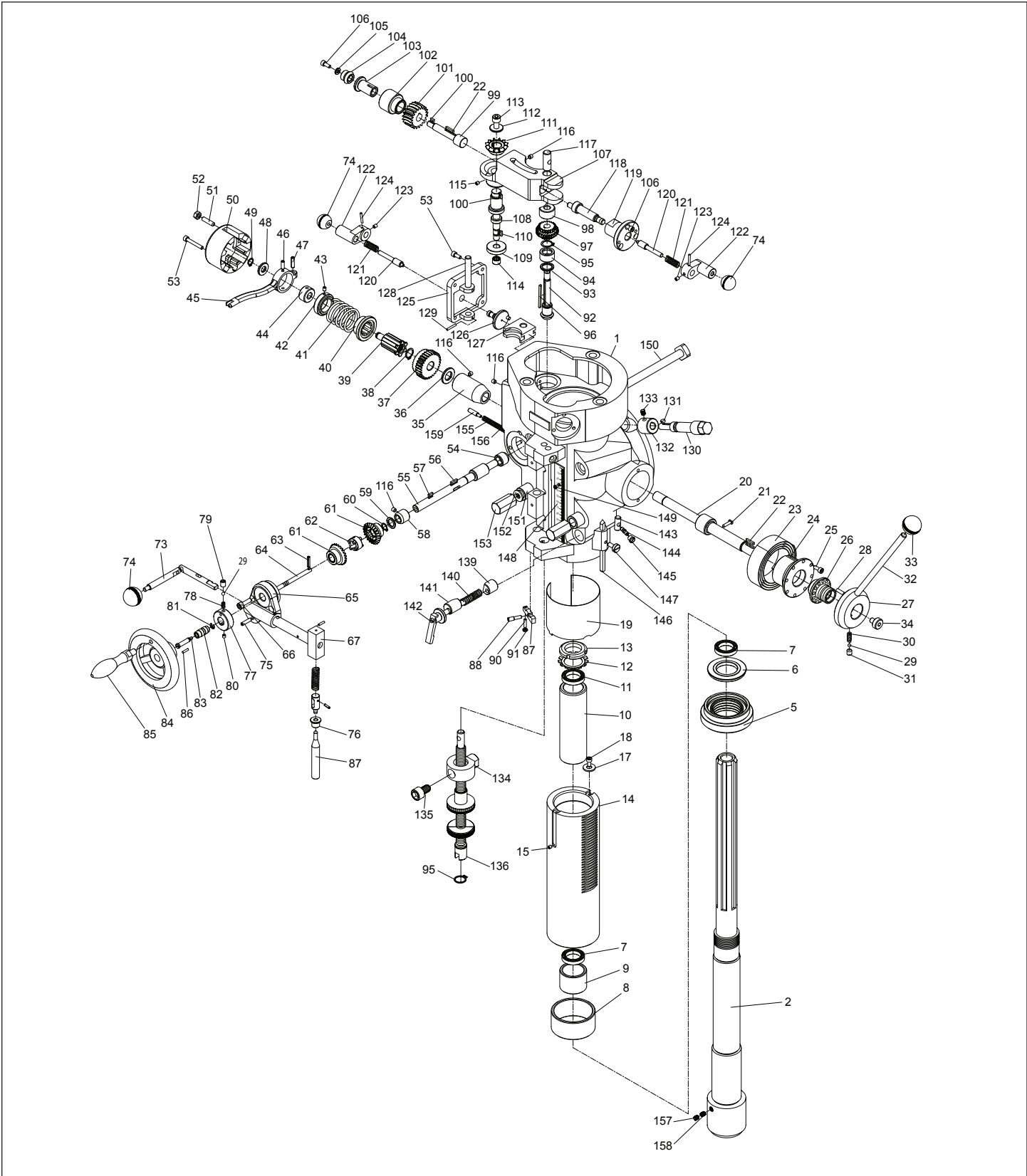

HEAD ASSEMBLY PARTS LIST

Index No.	Part No.	Description	Size	Qty.
1	ETM949-C01	Milling Head		1
2	ETM949-C02	Spindle	R8	1
3	ETM949-C03	Stop Block		2
4	TS-0208031	Hex Socket Head Cap Screw	5/16"x5/8"	2
5	ETM949-C05	Nut	R8	1
6	ETM949-C06	Spindle Dirt Shield		1
7	BB-7207	Bearing	7207	2
8A	ETM949-C08A	Bearing Spacer Assembly (Includes #8,9)		1
8	ETM949-C08	Bearing spacer (large)		1
9	ETM949-C09	Bearing spacer (large)		1
10	ETM949-C10	Sleeve		1
11	BB-6206	Bearing	6206	1
12	ETM949-C12	Lock Washer	AW-06	1
13	ETM949-C13	Locknut Washer	(M30)	1
14	ETM949-C14	Quill		1
15	ETM949-C15	Set Screw	M5×5	2
17	TS-1550031	Washer	M5	1
18	TS-1502021	Hex Socket Head Cap Screw	M5×10	2
19	ETM949-C19	Quill Skirt		1
20A	ETM949-C20A	Quill Pinion Shaft Assembly (Includes #20,21)		1
20	ETM949-C20	Quill Pinion Shaft		1
21	ETM949-C21	Pin		1
22	ETM949-C22	Flat Key	3×3×18	1
23	ETM949-C23	Clock Spring		1
24	ETM949-C24	Spring Cover		1
25	TS-1502031	Hex Socket Head Cap Screw	M5×12	2
26	ETM949-C26	Pinion Shaft Hub Sleeve		1
27	ETM949-C27	Back Feed Handle Hub (Quill Feed Lever)		1
28	ETM949-C28	Overload Clutch Lever Spring Plunger	Ø5×16"	1
29	ETM949-C29	Steel Ball	3/16"	2
30	ETM949-C30	Compression Spring		1
31	TS-0270031	Set Screw	5/16"×3/8"	1
32	ETM949-C32	Pinion Shaft Hub Handle		1
33	ETM949-C33	Black Plastic Ball	3/8"	1
34	ETM949-C34	Pinion Shaft Hub Screw		1
35	ETM949-C35	Quill Pinion Shaft Bushing		1
36	ETM949-C36	Quill Pinion Shaft Worm Gear Spacer		1
37	ETM949-C37	Overload Clutch Worm Gear		1
38	ETM949-C38	Snap Ring C-Type	S-15	1
39A	ETM949-C39A	Overload Clutch Assembly (Includes #39,40,42)		1
39	ETM949-C39	Over Load Clutch		1
40	ETM949-C40	Overload Clutch		1
41	ETM949-C41	Safety Clutch Spring		1
42	ETM949-C42	Overload Clutch Locknut		1



Index No.	Part No.	Description	Size	Qty.
43	ETM949-C43	Set Screw	M5×5	1
44	ETM949-C44	Clutch Ring		1
45	ETM949-C45	Overload Clutch Trip Lever		1
46	ETM949-C46	Clutch Ring Pin		2
47	ETM949-C47	Overload Clutch Lever Spring Plunger	Ø5×18	1
48	ETM949-C48	Overload Clutch Washer		1
49	ETM949-C49	Snap Ring C-Type	S-10	1
50	ETM949-C50	Clutch Arm Cover		1
51	TS-0267071	Set Screw	1/4"×3/4"	1
52	TS-0561011	Nut	1/4"	1
53	TS-1502081	Hex Socket Head Cap Screw	M5×35	2
54	ETM949-C54	Bushing		1
55	ETM949-C55	Feed Worm Shaft		1
56	ETM949-C56	Flat Key	3×3×15	1
57	ETM949-C57	Flat Key	3×3×10	1
58	ETM949-C58	Feed Worm Shaft Bushing		1
59	ETM949-C59	Feed Worm Shaft Thrust Washer		1
60	ETM949-C60	Snap Ring C-Type	S-12	1
61	ETM949-C61	Feed Reverse Bevel Gear		2
62	ETM949-C62	Feed Reverse Clutch		1
63	ETM949-C63	Overload Clutch Lever Spring Plunger	Ø3×20	1
64	ETM949-C64	Reverse Clutch Rod		1
65	ETM949-C65	Feed Trip Bracket		1
66	TS-1503051	Hex Socket Head Cap Screw	M6×20	2
67	ETM949-C67	Cam Rod Sleeve Assembly		1
73	ETM949-C73	Trip Handle		1
74	ETM949-C74	Black Plastic Ball 1/4" Dia	1/4"	3
75	ETM949-C75	Overload Clutch Lever Spring Plunger	Ø5×20	1
76	ETM949-C76	Trip Plunger Bushing		1
77	ETM949-C77	Hand wheel Clutch		1
78	ETM949-C78	Compression Spring		1
79	ETM949-C79	Hand wheel Clutch Spring Screw		1
80	TS-0267021	Set Screw	1/4"×1/4"	1
81A	ETM949-C81A	Feed Reverse Knob Assembly (Includes #81,82,83)		1
81	ETM949-C81	Snap Ring E-Type	E5	1
82	ETM949-C82	Feed Reverse Knob Stud		1
83	ETM949-C83	Feed Reverse Knob Stud Bolt		1
84A	ETM949-C84A	Hand wheel & Hand wheel Handle Assembly (#84,85)		1
84	ETM949-C84	Hand wheel & Hand wheel Handle		1
85	ETM949-C85	Handle	M8 P1.25	1
86	ETM949-C86	Overload Clutch Lever Spring Plunger	Ø3×16	1
87	ETM949-C87	Feed Trip Plunger		1
88	ETM949-C88	Trip Lever Pin		1
89	ETM949-C89	Feed Trip Lever		1

Index No.	Part No.	Description	Size	Qty.
90	TS-1521071	Set Screw	M4×20	1
91	TS-1540021	Nut	M4	1
92	ETM949-C92	Cluster Gear Shaft		1
93	ETM949-C93	Bevel Gear Thrust Spacer		1
94	ETM949-C94	Bevel Gear Bushing		1
95	ETM949-C95	Snap Ring C-Type	S-16	2
96	ETM949-C96	Flat Key	3×3×45	1
97	ETM949-C97	Cluster Gear		1
98	ETM949-C98	Cluster Gear Shaft Upper Bushing		1
99	ETM949-C99	Feed Drive Worm Gear Shaft		1
100	ETM949-C100	Flat Key	3×3×x8	2
101	ETM949-C101	Feed Drive Worm Gear		1
102	ETM949-C102	Worm Cradle Bushing		1
103	ETM949-C103	Feed Worm Gear Shaft Sleeve		1
104	ETM949-C104	Feed Bevel Pinion		1
105	ETM949-C105	Washer		1
106	TS-1502031	Hex Socket Head Cap Screw	M5×12	1
107	ETM949-C107	Worm Gear Cradle		1
108A	ETM949-C108A	Feed Driving Gear Assembly (includes #108, 110)		1
108	ETM949-C108	Feed Driving Gear		1
109	ETM949-C109	Feed Drive Gear		1
110	ETM949-C110	Flat Key	3×3×10	1
111	ETM949-C111	Feed Reverse Bevel Gear		1
112	ETM949-C112	Washer		1
113	TS-1504031	Hex Socket Head Cap Screw	M8×16	1
114	ETM949-C114	Bearing	BA66	1
115	ETM949-C115	Set Screw M6x25		1
116	TS-1523011	Set Screw	M6×6	3
117	ETM949-C117	Feed Engage Pin		1
118	ETM949-C118	Worm Gear Cradle Throw-Out		1
119	ETM949-C119	Shift Sleeve		1
120	ETM949-C120	Gear Shift Plunger		1
121	ETM949-C121	Compression Spring		1
122	ETM949-C122	Shift Crand		2
123	TS-0267021	Set Screw	1/4"×1/4"	2
124	ETM949-C124	Overload Clutch Lever Spring Plunger	3×20	2
125	ETM949-C125	Cluster Gear Cover		1
126	ETM949-C126	Cluster Gear Shift Crank		1
127	ETM949-C127	Feed Gear Shift Fork		1
128	ETM949-C128	Feed Shift Rod		1
129	ETM949-C129	Overload Clutch Lever Spring Plunger	3×18	1
130	ETM949-C130	Adj Worm Shaft		1
131	ETM949-C131	Flat Key	4×4×18	1
132	ETM949-C132	Warm Gear		1
133	ETM949-C133	Set Screw		1



Index No.	Part No.	Description	Size	Qty.
134	ETM949-C134	Quill Stop Knob		1
135	TS-0209021	Hex Socket Head Cap Screw	3/8"×5/8"	1
136	ETM949-C136	Quill Stop Micro-Screw (Meter)		1
139	ETM949-C139	Quill Lock Sleeve		1
140	ETM949-C140	Springs		2
141	ETM949-C141	Quill Lock Sleeve Tapped		1
142	ETM949-C142	Quill Lock Bolt & Spring	5/16"-18UNC	1
143	ETM949-C143	Feed Reverse Trip Plunger		1
144	ETM949-C144	Reverse Trip Ball Lever		1
145	ETM949-C145	Reverse Trip Ball Lever Screw		1
146	ETM949-C146	Indicator Rod		1
147	ETM949-C147	Indicator Rod Screw		1
148	ETM949-C148	Micrometer Scale(Inch)		1
149	ETM949-C149	Cross-Recessed Head Screw	1/8"×3/16"	1
150	ETM949-C150	Tee Bolt	1/2"-12 Nc	4
151	ETM949-C151	Lower Clamping Bolt Spacer		2
152	TS-0680061	Washer	1/2"	4
153	ETM949-C153	Adaptor Nut	1/2"-12nc	4
155	ETM949-C155	Hex-Socket Head Cap Screw	M4x15	1
156	ETM949-C156	Compression Spring		1
157	ETM949-C157	Special Socket Set Screw		1
158	ETM949-C158	Set Screw	M6×5	1
159	ETM949-C159	Overload Clutch Lever Spring Plunger		1
160	ETM949-C160	Draw bar w/washer (not shown)		1
	ETM949-HA	Complete Mill Head Assembly (logo, labels, upper head, lower head parts) <i>with</i> Motor		
	ETM949-HAWOM	Complete Mill Head Assembly (logo, labels, upper head, lower head parts) <i>without</i> Motor		
	ETM949EVS-HA	Complete Mill Head Assembly (logo, labels, upper head, lower head parts) <i>with</i> Motor		
	ETM949EVS-HAWOM	Complete Mill Head Assembly (logo, labels, upper head, lower head parts) <i>without</i> Motor		

UPPER HEAD ASSEMBLY — ETM-949

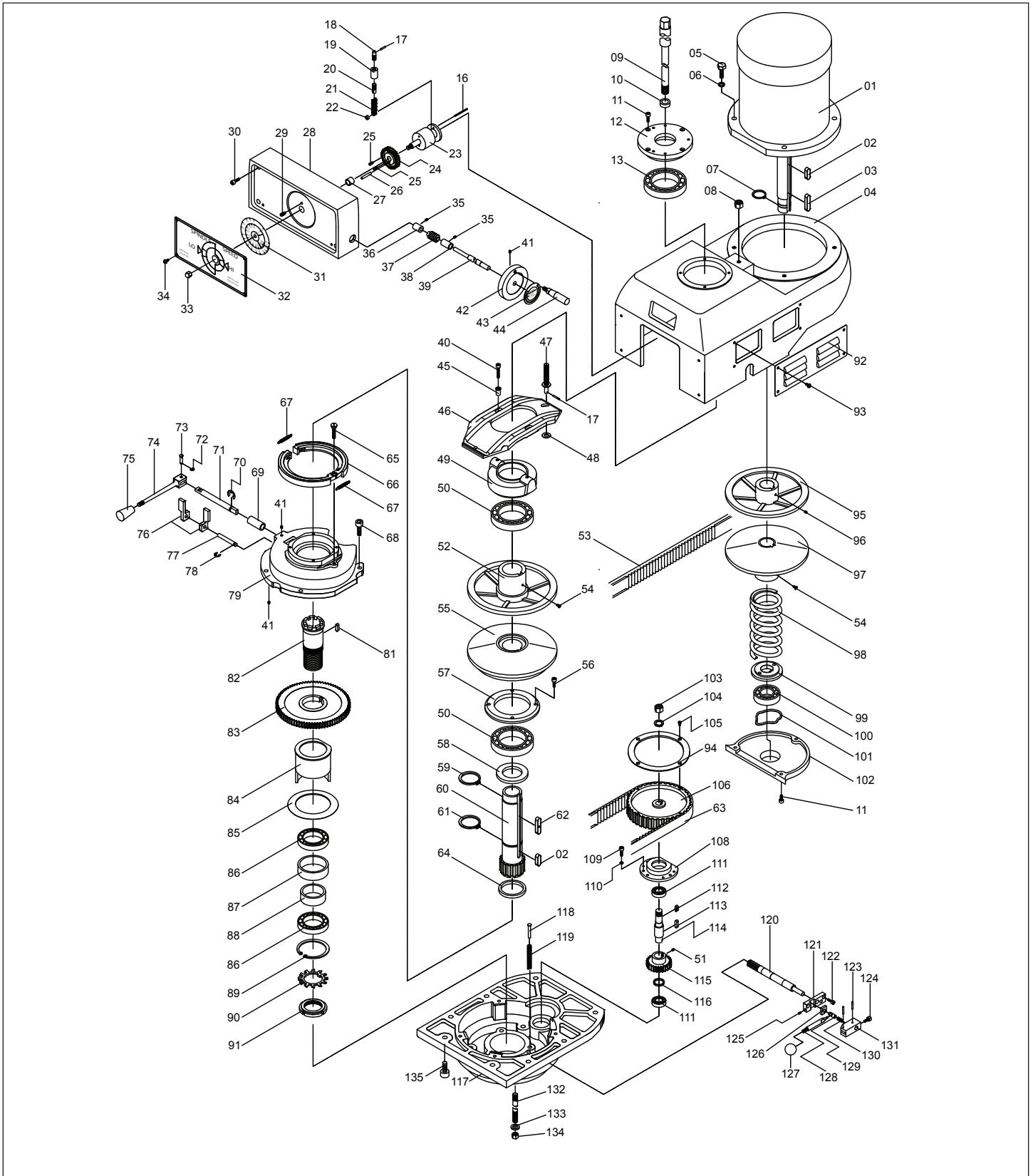



UPPER HEAD ASSEMBLY PARTS LIST

Index No.	Part No.	Description	Size	Qty.
1	ETM949-D01	Motor		1
	ETM949-D01A	Motor With Pulley Assembly (includes # 1,2,3,7,54,95-99)	1	
2	ETM949-D02	Key	10×8×10	2
3	ETM949-D03	Key		1
4	ETM949-D04	Upper Pulley Box		1
5	TS-0209051	Screw	3/8"×1"	2
6	TS-0733061	Spring Washer	3/8"	4
7	ETM949-D07	Snap Ring C-Type	S-30	2
8	TS-0561031	Nut	3/8"	1
	ETM949-D09A	Draw Bar w/ Nut Assembly(included # 9-10)	7/16"-20UNF	1
9	ETM949-D09	Draw Bar Nst#30 1/2" 12unf		1
10	ETM949-D10	Washer (NT#30) S45C/cm		1
11	TS-1503051	Hex Socket Head Cap Screw	M6×20	4
12	ETM949-D12	Top Bearing Bracket		1
13	BB-6007	Ball Bearing	6007	1
16	ETM949-D16	Hi-Low Detent Plunger	Ø3×40	1
17	ETM949-D17	Hi-Low Detent Plunger	Ø4×20	1
18	ETM949-D18	Speed Change Chain Stud		1
19	ETM949-D19	Speed Change Chain Stud		1
20	ETM949-D20	Speed Change Chain Stud		1
21	ETM949-D21	Chain	#35-8P	1
22	ETM949-D22	Chain Washer		1
23	ETM949-D23	Speed Change Chain Drum		1
24	ETM949-D24	Feed Drive Worm Gear		1
25	ETM949-D25	Hi-Low Detent Plunger	Ø5×10	2
26	ETM949-D26	Hi-Low Detent Plunger	Ø5×30	1
27	ETM949-D27	Bushing		1
28	ETM949-D28	Speed Change Housing		1
29	ETM949-D29	Lock Screw		1
30	TS-1503081	Hex Socket Head Cap Screw	M6×35	4
31	ETM949-D31	Vari Speed Dial 60 Hz		1
32	ETM949-D32	Speed Ind. Plate		1
33	TS-0561021	Nut	5/16"	1
34	ETM949-D34	Type III Phillips Screws	M4×6	4
35	TS-1522011	Set Screw	M5×6	3
36	ETM949-D36	Compression Spring		1
37	ETM949-D37	Worm		1
38	ETM949-D38	Worm Cradle Bushing		1
39	ETM949-D39	Speed Control Shaft		1
40	TS-1502051	Hex Socket Head Cap Screw	M5×20	2
41	TS-1523011	Set Screw	M6×6	3
42	ETM949-D42	Handle		1
43	ETM949-D43	Speed Change Warring Plate		1
44	ETM949-D44	Handle	5/16"-18UNC	1
45	ETM949-D45	Pivot Sleeve		2
46	ETM949-D46	Speed Change Plate		1

Index No.	Part No.	Description	Size	Qty.
47	ETM949-D47	Speed Change Plate Pivot Stud		1
48	ETM949-D48	Clutch Washer	10.2×21×1.2	1
49	ETM949-D49	Sliding Housing		1
50	BB-6010	Ball Bearing	6010	2
51	ETM949-D51	Set Screw	M8×6	1
52	ETM949-D52	Adj. Driven Vari-Disc Assembly		1
53	ETM949-D53	Belt 38X890		1
54	TS-2245081	Screw	M5×8	2
55	ETM949-D55	Stationary Driven Vari-Disc		1
56	TS-1503051	Hex Socket Head Cap Screw	M6×20	4
57	ETM949-D57	Brake Brg. Cap		1
58	ETM949-D58	Spindle Pulley Spacer		1
59	ETM949-D59	Snap Ring C-Type	S-35	1
60	ETM949-D60	Spindle Clutch Device		1
61	ETM949-D61	Snap Ring C-Type	S-40	1
62	ETM949-D62	Sliding Key		1
63	ETM949-D63	Timing Belt 225l		1
64	ETM949-D64	Timing Pulley Clutch Sleeve		1
65	ETM949-D65	Brake Ring Screw		1
66	ETM949-D66	Brake Shoe		1
67	ETM949-D67	Brake Spring		2
68	TS-1504041	Hex Socket Head Cap Screw	M8×20	3
69	ETM949-D69	Sleeve For Brake		1
70	ETM949-D70	Snap Ring C-Type	S-12	1
71	ETM949-D71	Brake Lock Shaft		1
72	ETM949-D72	Snap Ring E-Type	E-4	1
73	ETM949-D73	Brake Lock Pin, S45C		1
74	ETM949-D74	Brake Lock & Handle		1
75	ETM949-D75	Black Plastic Ball Handle	5/16"-18UNC	1
76	ETM949-D76	Brake Finger Pivot Stud		2
77	ETM949-D77	Brake Operation Finger		1
78	ETM949-D78	Snap Ring E-Type	E-6	1
79	ETM949-D79	Brake Base		1
81	ETM949-D81	Key	8×12	1
82	ETM949-D82	Spindle Pulley Hub		1
83	ETM949-D83	Spindle Bull Gear Assembly		1
84	ETM949-D84	Bull Gear Bearing Sleeve		1
85	ETM949-D85	Bull Gear Bearing Sleeve Washer		1
86	BB-6908	Ball Bearing	6908	2
87A	ETM949-D87A	Bull Gear Bearing Spacer Assembly (includes #87,88)		1
87	ETM949-D87	Bull Gear Bearing Spacer		1
88	ETM949-D88	Bull Gear Bearing Spacer		1
89	ETM949-D89	Snap Ring C-Type	R-62	1
90	ETM949-D90	Spacer	AW08	1
91	ETM949-D91	Bearing Lock Nut		1
92	ETM949-D92	Side Belt Housing Cover		2



Index No.	Part No.	Description	Size	Qty.
93	ETM949-D93	Cross-Recessed Head Screw	M6×8	8
94	ETM949-D94	Timing Belt Pulley Flange		1
95	ETM949-D95	Stationary Motor Vari-Disc		1
96	TS-1523021	Set Screw	M6×8	1
97	ETM949-D97	Adj.Motor Vari-Disc		1
98	ETM949-D98	Spring		1
99	ETM949-D99	Spring Washer		1
100	BB-6204	Ball Bearing	6204	1
101	ETM949-D101	Washer	6204	1
102	ETM949-D102	Motor Pulley Cover		1
103	TS-0561071	Nut	5/8"	1
104	TS-0680081	Washer	5/8"	1
105	ETM949-D105	Countersunk Screws	M5×8	4
106	ETM949-D106	Pullet Set		1
108	ETM949-D108	Cover		1
109	TS-1502041	Hex Socket Head Cap Screw	M5×16	3
110	TS-1550031	Washer	M5	3
111	BB-6203	Ball Bearing	6203	2
112	ETM949-D112	Key	5×15	1
113	ETM949-D113	Key	5×18	1
114	ETM949-D114	Bull Gear Pinion Counter Shaft		1
115	ETM949-D115	Bull Gear Pinion Counter Gear		1
116	ETM949-D116	Spacer		1
117	ETM949-D117	Gear Housing		1
118	ETM949-D118	Spring Supported Pin		3
119	ETM949-D119	Spring		3
120	ETM949-D120	Bull Gear Shifter Pinion Shaft		1
121	ETM949-D121	Hi-Low Detent Plate		1
122	TS-1502031	Hex Socket Head Cap Screw	M5×12	2
123	ETM949-D123	Hi-Low Detent Plunger	Ø3×20	2
124	TS-1503031	Hex Socket Head Cap Screw	M6×16	1
125	TS-1521051	Set Screw	M4×16	1
126	ETM949-D126	Adj. Plate		1
127	ETM949-D127	Black Plastic Ball 1/4" Dia	1/4"-20UNC	1
128	ETM949-D128	Hi-Low Shift Crank		1
129	ETM949-D129	Hi-Low Detent Plunger		1
130	ETM949-D130	Spring		1
131	ETM949-D131	Hi-Low Pinion Block		1
132	ETM949-D132	Studs		3
133	ETM949-D133	Washer		3
134	TS-0561041	Nut	7/16"	3
135	TS-1504051	Hex Socket Head Cap Screw	M8x25	6

UPPER HEAD ASSEMBLY — ETM-949EVS

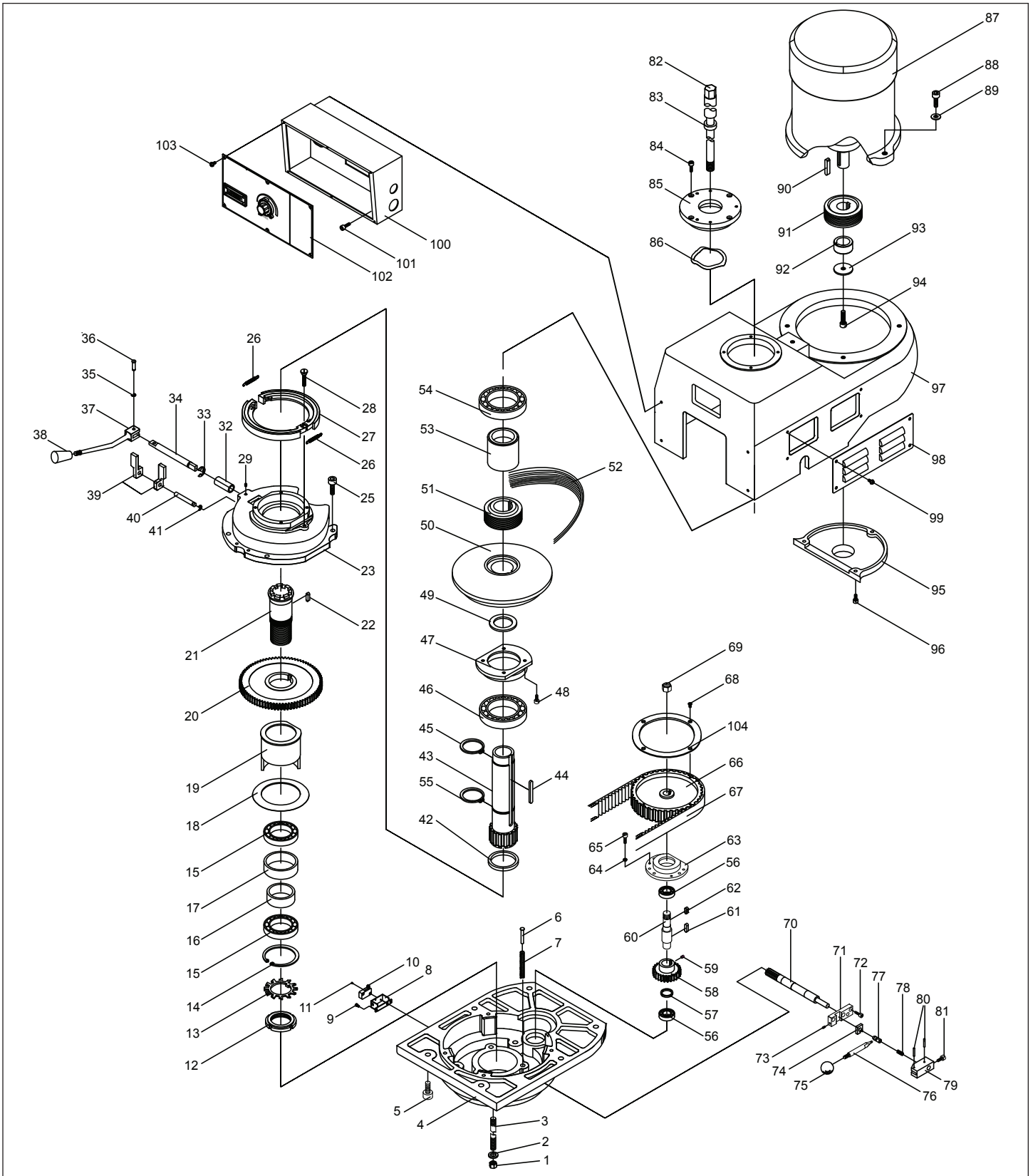



UPPER HEAD ASSEMBLY PARTS LIST

Index No.	Part No.	Description	Size	Qty.
1	TS-0561041	Nut	7/16"	3
2	ETM949-D133	Washer		3
3	ETM949-D132	Studs		3
4	ETM949-D117	Gear Housing		1
5	TS-1504051	Hex Socket Head Cap Screw	M8×25	6
6	ETM949-D118	Spring Supported Pin		3
7	ETM949-D119	Spring		3
8	ETM949EVS-D08	Limit Switch		1
9	TS-1501031	Hex Socket Head Cap Screw	M4×10	2
10	ETM949EVS-D10	Limit Switch	D2VW-5L2A-1M	1
11	TS-1540011	Nut	M3×8	2
12	ETM949-D91	Bearing Lock Nut		1
13	ETM949-D90	Spacer	AW08	1
14	ETM949-D89	Snap Ring C-Type	R-62	1
15	BB-6908	Ball Bearing	6908	2
16	ETM949-D88	Bull Gear Bearing Spacer		1
17	ETM949-D87	Bull Gear Bearing Spacer		1
18	ETM949-D85	Bull Gear Bearing Sleeve Washer		1
19	ETM949-D84	Bull Gear Bearing Sleeve		1
20	ETM949-D83	Spindle Bull Gear Assembly		1
21	ETM949-D82	Spindle Pulley Hub		1
22	ETM949EVS-D22	Key	8×12	1
23	ETM949-D79	Brake Base		1
25	TS-1504041	Hex Socket Head Cap Screw	M8×20	4
26	ETM949-D67	Brake Spring		2
27	ETM949-D66	Brake Shoe		1
28	ETM949EVS-D28	Brake Ring Screw	1/4"-20UNC	1
29	TS-1523011	Set Screw	M6×6	1
32	ETM949-D69	Sleeve For Brake		1
33	ETM949-D70	Snap Ring C-Type	S-12	1
34	ETM949-D71	Brake Lock Shaft		1
35	ETM949-D72	Snap Ring E-Type	E-4	1
36	ETM949-D73	Brake Lock Pin	S45C	1
37	ETM949-D74	Brake Lock & Handle		1
38	ETM949-D75	Black Plastic Ball Handle	5/16"-18UNC	1
39	ETM949-D76	Brake Finger Pivot Stud		2
40	ETM949-D77	Brake Operation Finger		1
41	ETM949-D78	Snap Ring E-Type	E-6	1
42	ETM949-D64	Timing Pulley Clutch Sleeve		1
43	ETM949EVS-D43	Spindle Clutch Device		1
44	ETM949EVS-D44	Key	7×8×50	1
45	ETM949-D59	Snap Ring C-Type	S-35	1
46	BB-6010	Ball Bearing	6010	2
47	ETM949EVS-D47	Brake Brg. Cap		1
48	TS-1503051	Hex Socket Head Cap Screw	M6×20	4
49	ETM949EVS-D49	Spindle Pulley Spacer		1
50	ETM949EVS-D50	Stationary Driven Vari-Disc		1
51	ETM949EVS-D51	Spindle Pulley		1
52	ETM949EVS-D52	Spindle Belt	300J10	1
53	ETM949EVS-D53	Spacer		1

Index No.	Part No.	Description	Size	Qty.
54	BB-6007	Bearing	6007	1
55	ETM949-D61	Snap Ring C-Type	S-40	1
56	BB-6203	Bearing	6203	2
57	ETM949EVS-D57	Spacer		1
58	ETM949-D115	Bull Gear Pinion Counter Gear		1
59	ETM949EVS-D59	Set Screw	M8×6	1
60	ETM949-D114	Bull Gear Pinion Counter Shaft		1
61	ETM949EVS-D61	Key	5×18	1
62	ETM949EVS-D62	Key	5×15	1
63	ETM949-D108	Cover		1
64	TS-2361051	Washer	M5	3
65	TS-1502041	Hex Socket Head Cap Screw	M5×16	3
66	ETM949-D106	Pullet Set		1
67	ETM949-D63	Timing Belt 225l		1
68	ETM949EVS-D68	Screw	M5×8	4
69	TS-0561071	Nut	5/8"	1
70	ETM949-D120	Bull Gear Shifter Pinion Shaft		1
71	ETM949-D121	Hi-Low Detent Plate		1
72	TS-1502031	Hex Socket Head Cap Screw	M5×12	2
73	TS-1501051	Hex Socket Head Cap Screw	M4×16	1
74	ETM949-D126	Adj. Plate		1
75	ETM949-D127	Black Plastic Ball 1/4" Dia	1/4"-20UNC	1
76	ETM949-D128	Hi-Low Shift Crank		1
77	ETM949-D129	Hi-Low Detent Plunger		1
78	ETM949-D130	Spring		1
79	ETM949-D131	Hi-Low Pinion Block		1
80	ETM949EVS-D80	Hi-Low Detent Plunger	Ø3×20	2
81	TS-1503041	Hex Socket Head Cap Screw	M6×16	1
	ETM949-D09A	Draw Bar W/ Nut Assembly (includes # 82-83)	7/16"-20UNF	1
82	ETM949-D09	Draw Bar	7/16"	1
83	ETM949-D10	Washer (Nt#30) S45c/Cm	M5×8	1
84	TS-1503051	Hex Socket Head Cap Screw	M6×20	4
85	ETM949EVS-D85	Top Bearing Bracket		1
86	ETM949EVS-D86	Spring	6007	1
87	ETM949EVS-D87	Motor		1
88	TS-0209051	Hex Socket Head Cap Screw	3/8"× 1"	2
89	TS-0680042	Washer	3/8"	2
90	ETM949EVS-D90	Key	8×8×35	1
91	ETM949EVS-D91	Motor Pulley		1
92	ETM949EVS-D92	Spacer	Ø40×19	1
93	TS-1550061	Washer	M8	1
94	TS-1504061	Hex Socket Head Cap Screw	M8×30	1
95	ETM949-D102	Motor Pulley Cover		1
96	TS-1503051	Hex Socket Head Cap Screw	M6×20	4
97	ETM949EVS-D97	Upper Gear Box		1
98	ETM949-D92	Side Belt Housing Cover		2
99	ETM949EVS-D99	Cross-Recessed Head Screw	M6×8	8
100	ETM949EVS-D100	Electric Box		1
101	ETM949EVS-D101	Hex Socket Head Cap Screw	M5×6	4
102	ETM949EVS-D102	Control Panel		1
103	ETM949EVS-D103	Cross-Recessed Head Screw	3/16"×10	6
104	ETM949-D94	Timing Belt Pulley Flange		1

ELECTRICAL ASSEMBLY — ETM-949

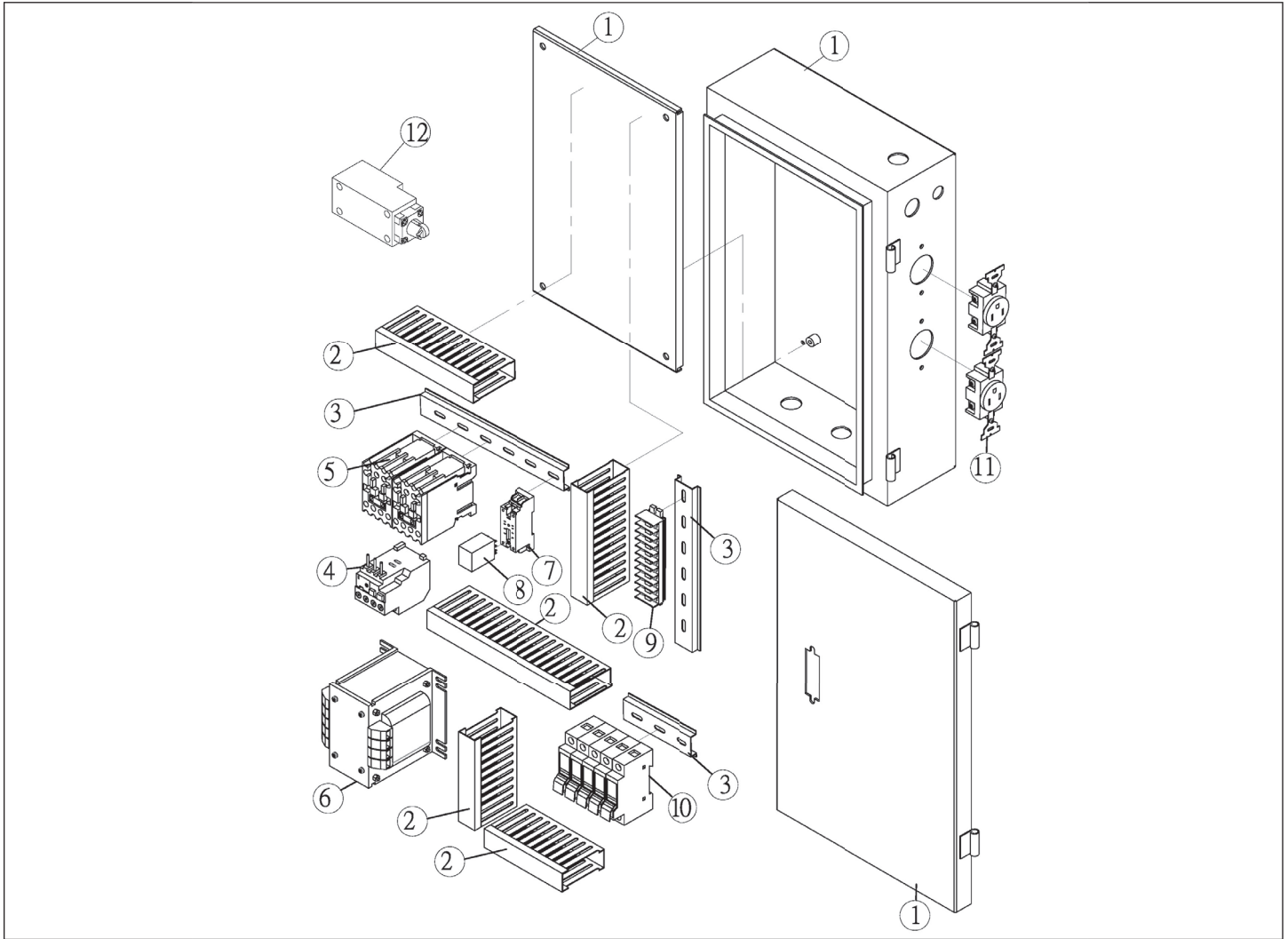

ELECTRICAL PARTS LIST — ETM-949

Index No.	Part No.	Description	Size	Qty.
1	ETM949-E01	Electric Box Assembly		1
2	ETM949-E02	Wire Housing		3
3	ETM949-E03	Aluminum Plate		2
4	ETM949-E04	Overload (ETM949 only)	7.2-10A	1
5	ETM949-E05	Magnetic Switch	CU11	1
6	ETM949-E06	Transformer		1
7	ETM949-E07	Relay Switch Base		1
8	ETM949-E08	Relay Switch		1
9	ETM949-E09	Terminal Block Plate		1
10	ETM949-E10	Fuse Base		5
	ETM949-F2A	Fuse (not shown)	2A	1
	ETM949-F4A	Fuse (not shown)	4A	1
	ETM949-F20A	Fuse (not shown)	20A	3
11	ETM949-E11	Power Socket		2
12	ETM949-E19	Limit Switch		1

INVERTER ELECTRICAL ASSEMBLY — ETM-949EVS

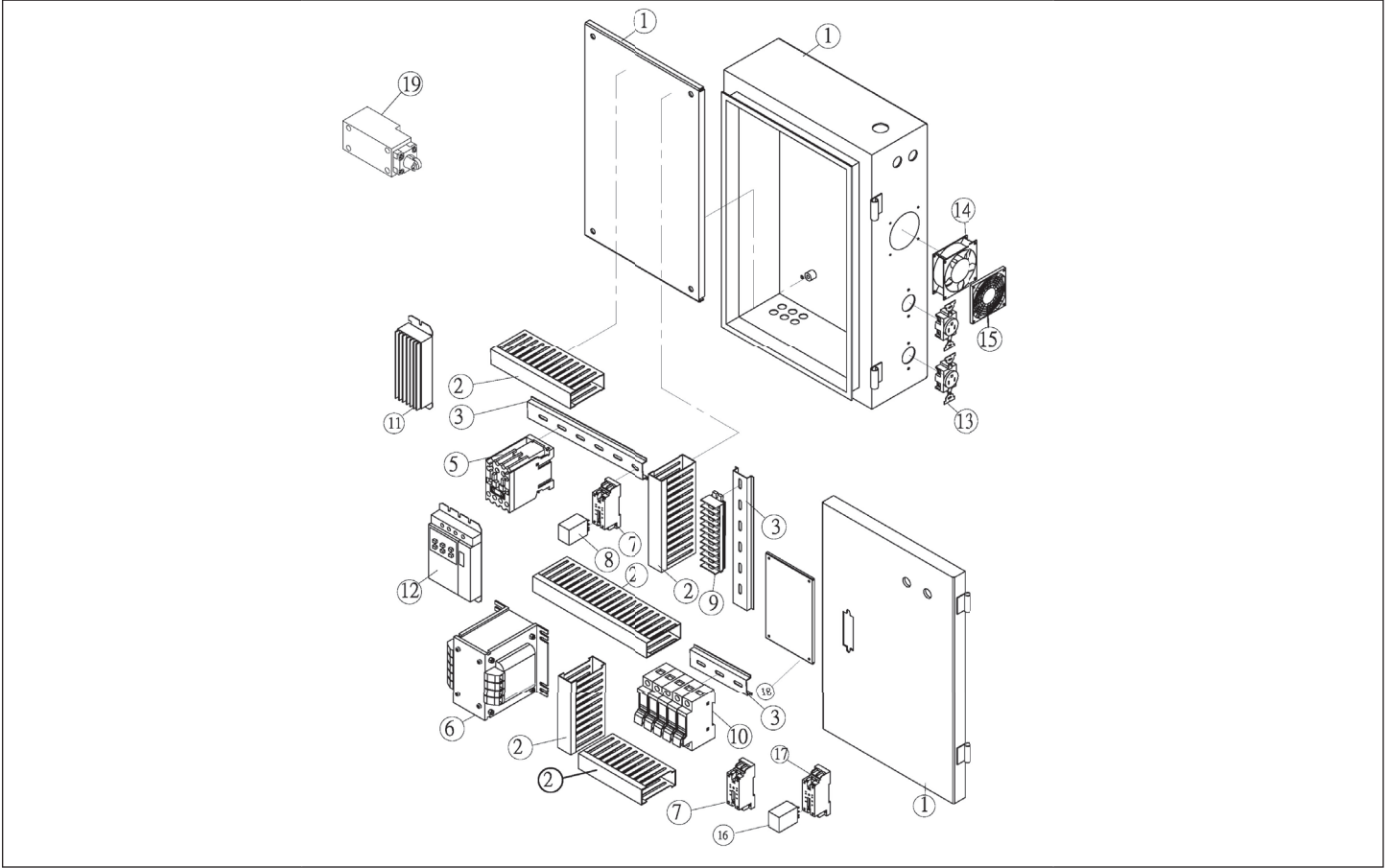

INVERTER ELECTRICAL PARTS LIST — ETM-949EVS

Index No.	Part No.	Description	Size	Qty.
1	ETM949EVS-E01	EVS Inverter Electric Box Assembly		1
2	ETM949-E02	Wire Housing		2
3	ETM949-E03	Aluminum Plate		2
5	ETM949-E05	Magnetic Switch (serial No. 13080024 and lower)	CU11	1
	ETM949-E05N	Magnetic Switch (serial No. 14070035 and higher)	CU18	1
6	ETM949-E06	Transformer		1
7	ETM949-E07	Relay Switch Base	AC24V	2
8	ETM949-E08	Relay Switch	AC24V	1
9	ETM949-E09	Terminal Block Plate		1
10	ETM949-E10	Fuse Base		5
	ETM949-F2A	Fuse (not shown)	2A	1
	ETM949-F4A	Fuse (not shown)	4A	1
	ETM949-F20A	Fuse (not shown)	20A	3
	ETM949EVS-F25A	Fuse (not shown)(option)	25A	2
11	ETM949EVS-E11	Heatsink		1
12	ETM949EVS-E12	Inverter (serial No. 13080024 and lower)	230V 3PH E type	1
	ETM949EVS-E12-1PH	Inverter (serial No. 14070035 and higher)	230V 1/3PH B type	1
13	ETM949-E11	Power Socket		2
14	ETM949EVS-E14	Fan		1
15	ETM949EVS-E15	Filter		1
16	ETM949EVS-E16	Relay Switch	DC24V	1
17	ETM949EVS-E17	Relay Switch Base	DC24V	1
18	ETM949EVS-E18	PC board		1
19	ETM949-E19	Limit Switch		1

HEAD CONTROL PANEL — ETM-949EVS

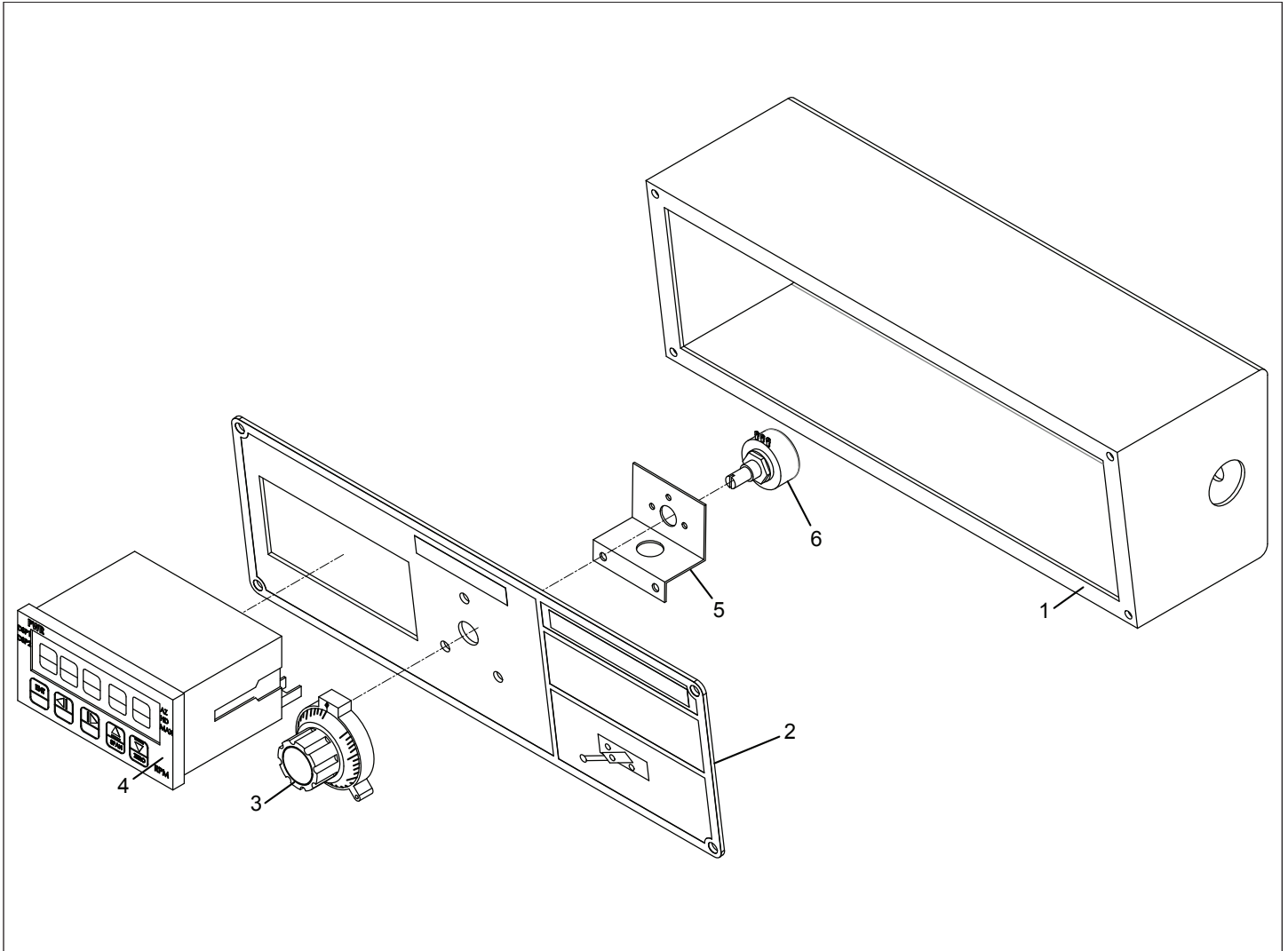

HEAD CONTROL PANEL PARTS LIST

Index No.	Part No.	Description	Size	Qty.
1	ETM949EVS-D100	Control Box for EVS		1
2	ETM949EVS-D102	Control Panel for EVS		1
3	ETM949EVS-F03	VR Knob		1
4	ETM949EVS-F04	Digital Readout		1
5	ETM949EVS-F05	Metal Plate		1
6	ETM949EVS-F06	VR Variable Resistor		1

CONTROL PANEL ASSEMBLY — ETM-949, ETM-949EVS

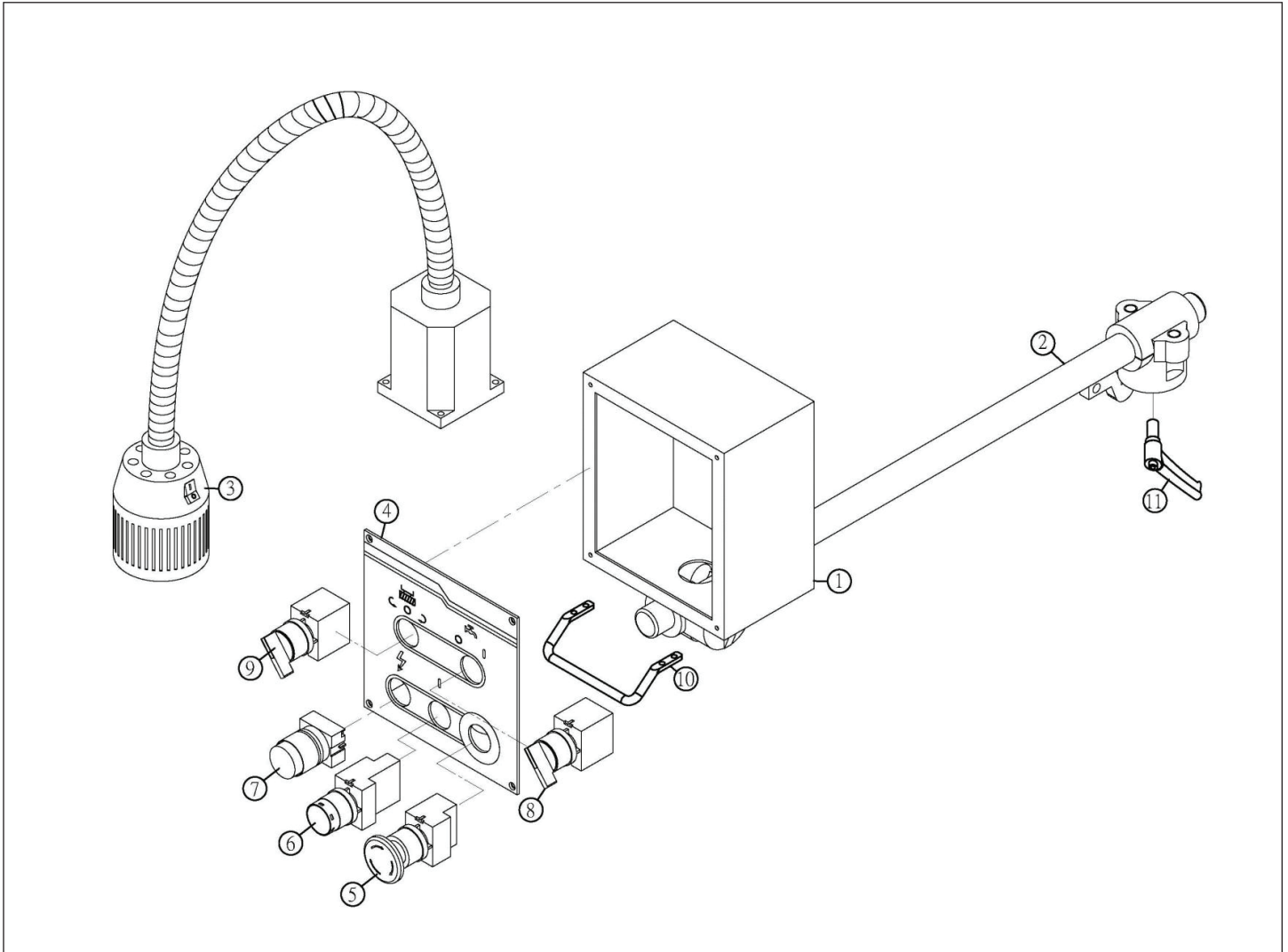

CONTROL PANEL ASSEMBLY PARTS LIST

Index No.	Part No.	Description	Size	Qty.
1	ETM949-G01	Control Panel Box		1
2	ETM949-G02	Support Bar Assembly		1
3	ETM949-G03	Work Lamp		1
4	ETM949-G04	Control Panel label		1
5	ETM949-G05	Emergent Switch		1
6	ETM949-G06	Start Switch		1
7	ETM949-G07	Power Light		1
8	ETM949-G08	Coolant Pump Switch *		1
9	ETM949-G09	F/R Switch		1
10	ETM949-G10	Handle		1
11	ETM949-G11	Knob		1

* optional accessory, supplied with 894092 Coolant System

SPINDLE SHAFT GUARD ASSEMBLY — ETM-949, ETM-949EVS

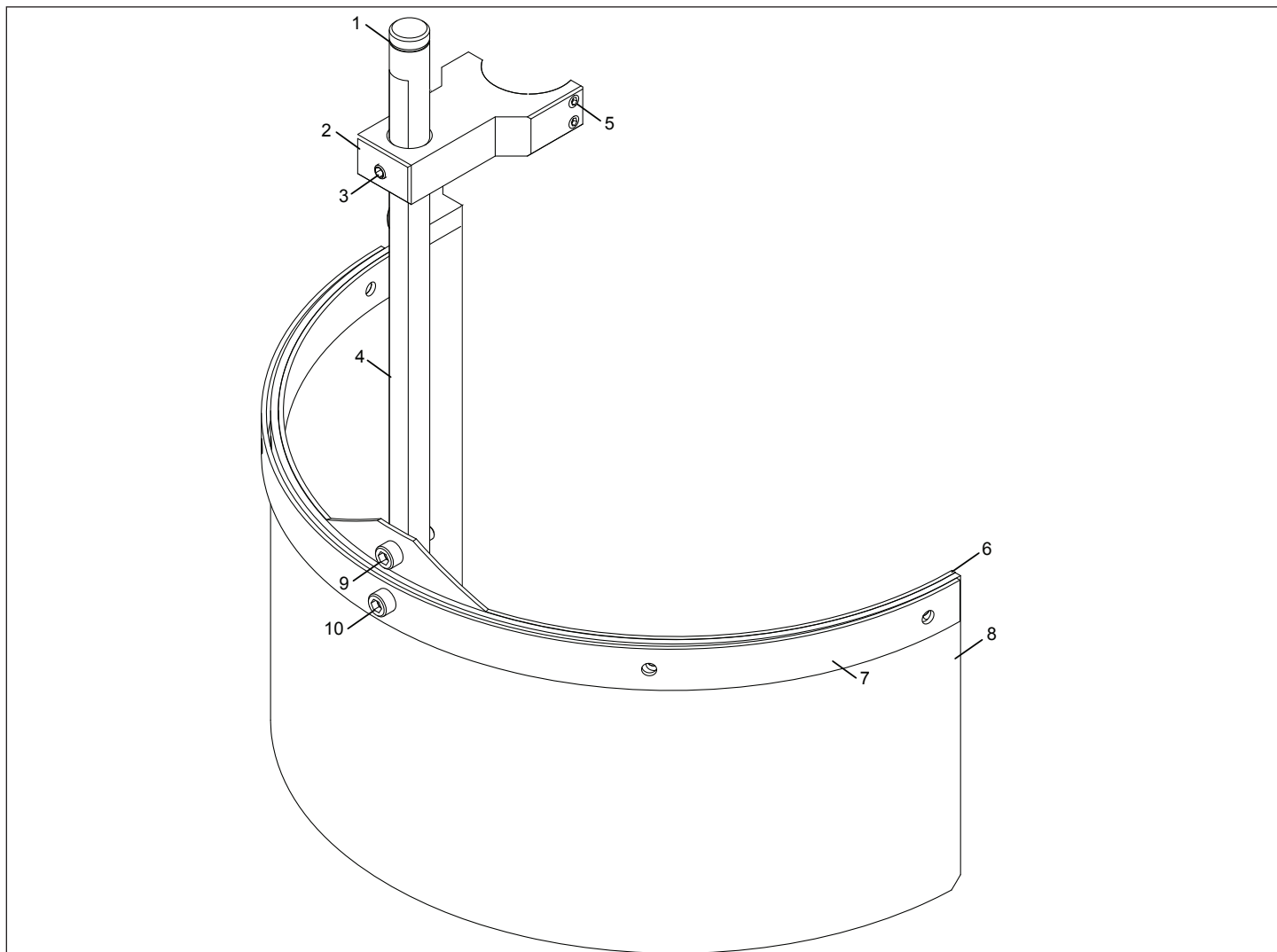

SPINDLE SHAFT GUARD PARTS LIST

Index No.	Part No.	Description	Size	Qty.
1	ETM949-H01	Snap Ring C-Type	S-16	1
2	ETM949-H02	Cover		1
3	TS-1503021	Set Screw	M6x10	1
4	ETM949-H04	Shaft		1
5	TS-1502051	Hex Socket Head Cap Screw	M5x20	1
6	ETM949-H06	Guard mounting plate (I)		1
7	ETM949-H07	Guard mounting plate (II)		1
8	ETM949-H08	Guard		1
9	ETM949-H09	Hex Socket Head Cap Screw	M6x15	1
10	TS-1503051	Hex Socket Head Cap Screw	M6x20	1

LUBRICATION SYSTEM ASSEMBLY — ETM-949, ETM-949EVS

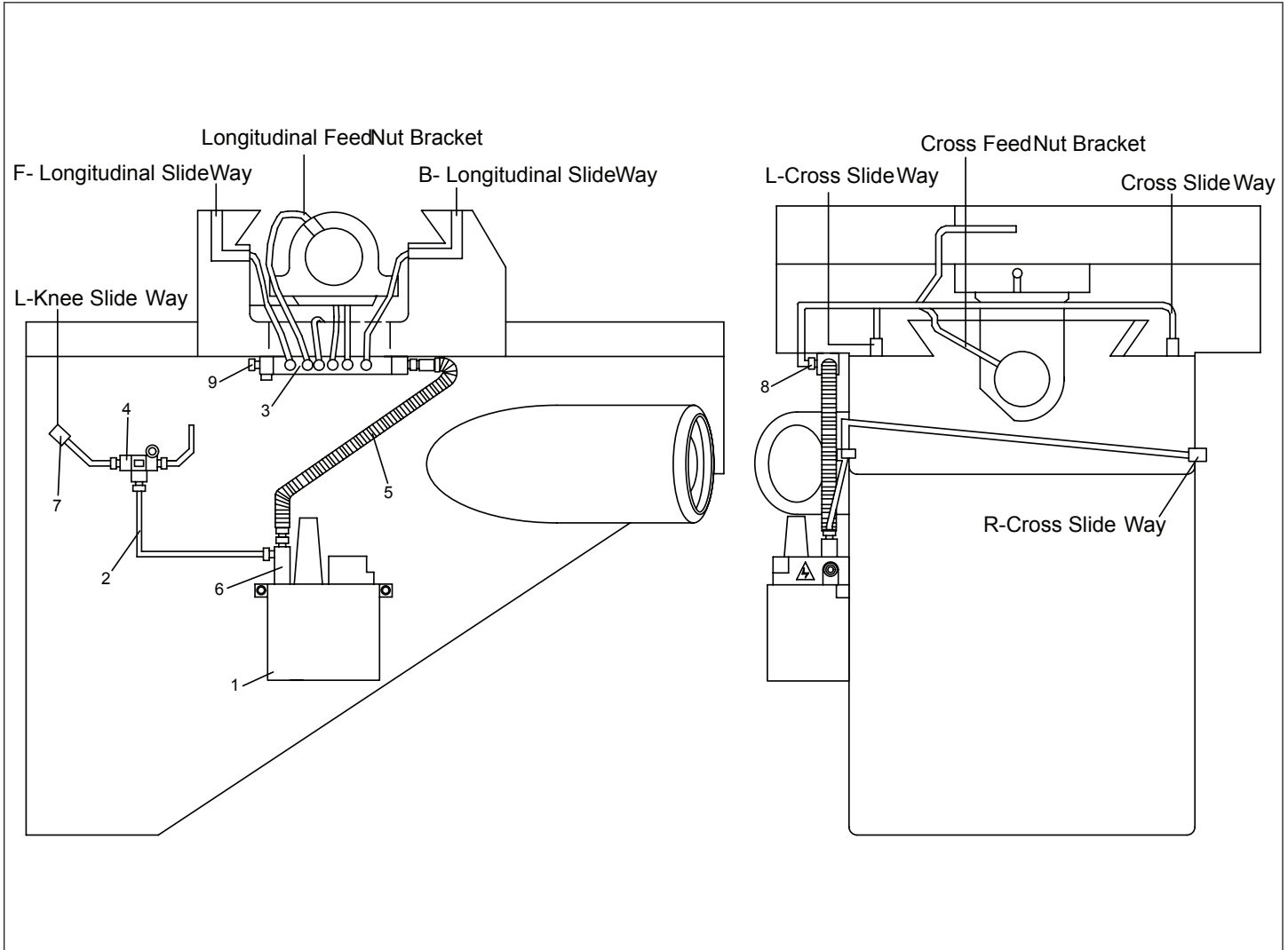

LUBRICATION SYSTEM PARTS LIST

Index No.	Part No.	Description	Size	Qty.
1	ETM949-B79	Automatic Oiler		1
2	ETM949-I02	Aluminum Pipe		1
3	ETM949-I03	Oil Regulating Distributor		1
3A	ETM949-I03A	Oil Regulating Distributor Assembly (includes #3-5, 7-9)		1
4	ETM949-I04	T-Joint		1
5	ETM949-I05	Flexible Steel Tube		1
6	ETM949-I06	Check Joint		2
7	ETM949-I07	Elbow Joint		2
8	ETM949-I08	Straight Joint		14
9	ETM949-I09	Union		1

WIRING DIAGRAM — ETM-949EVS (E type inverter)

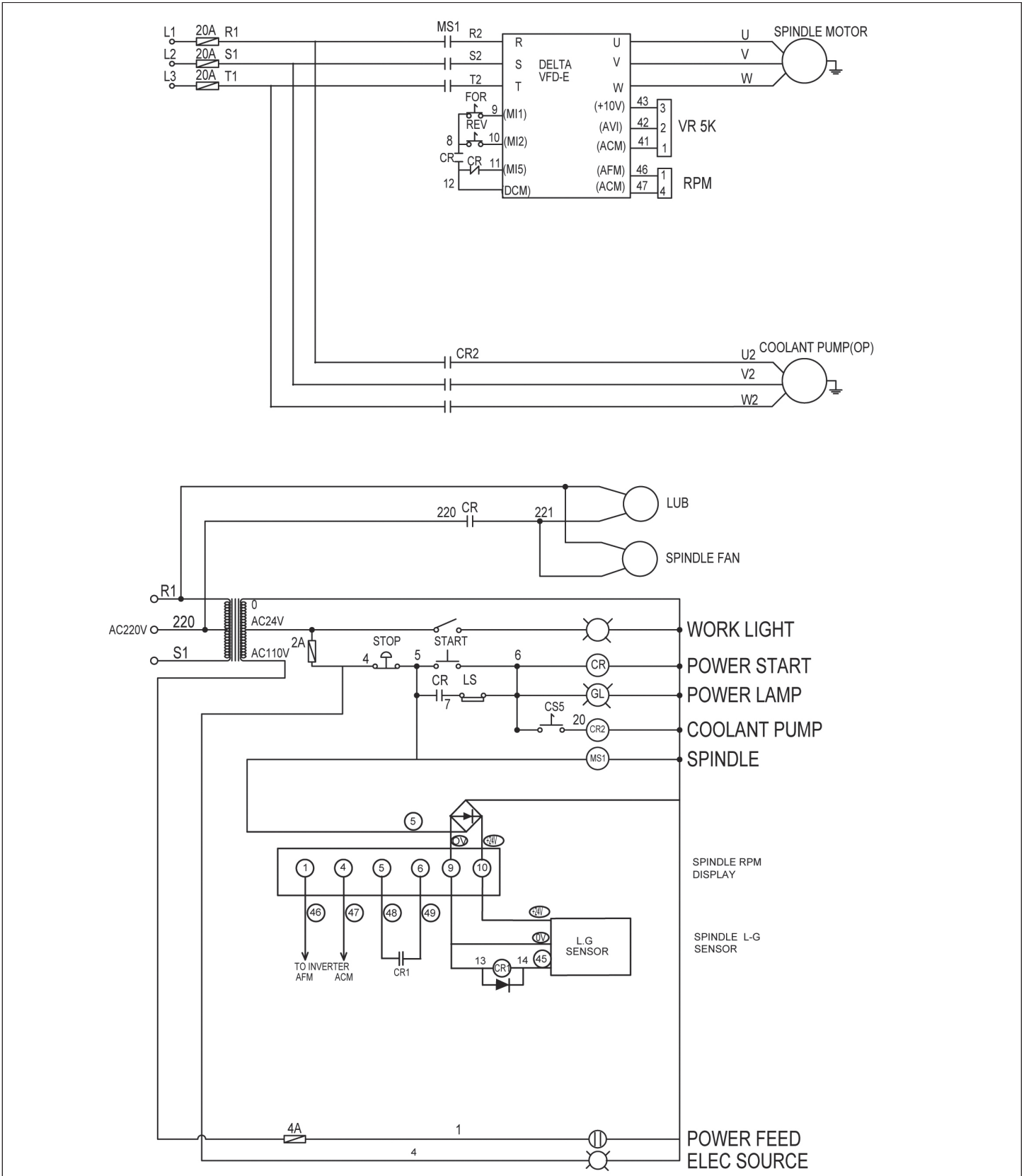

WIRING DIAGRAM — ETM-949EVS (B type inverter)

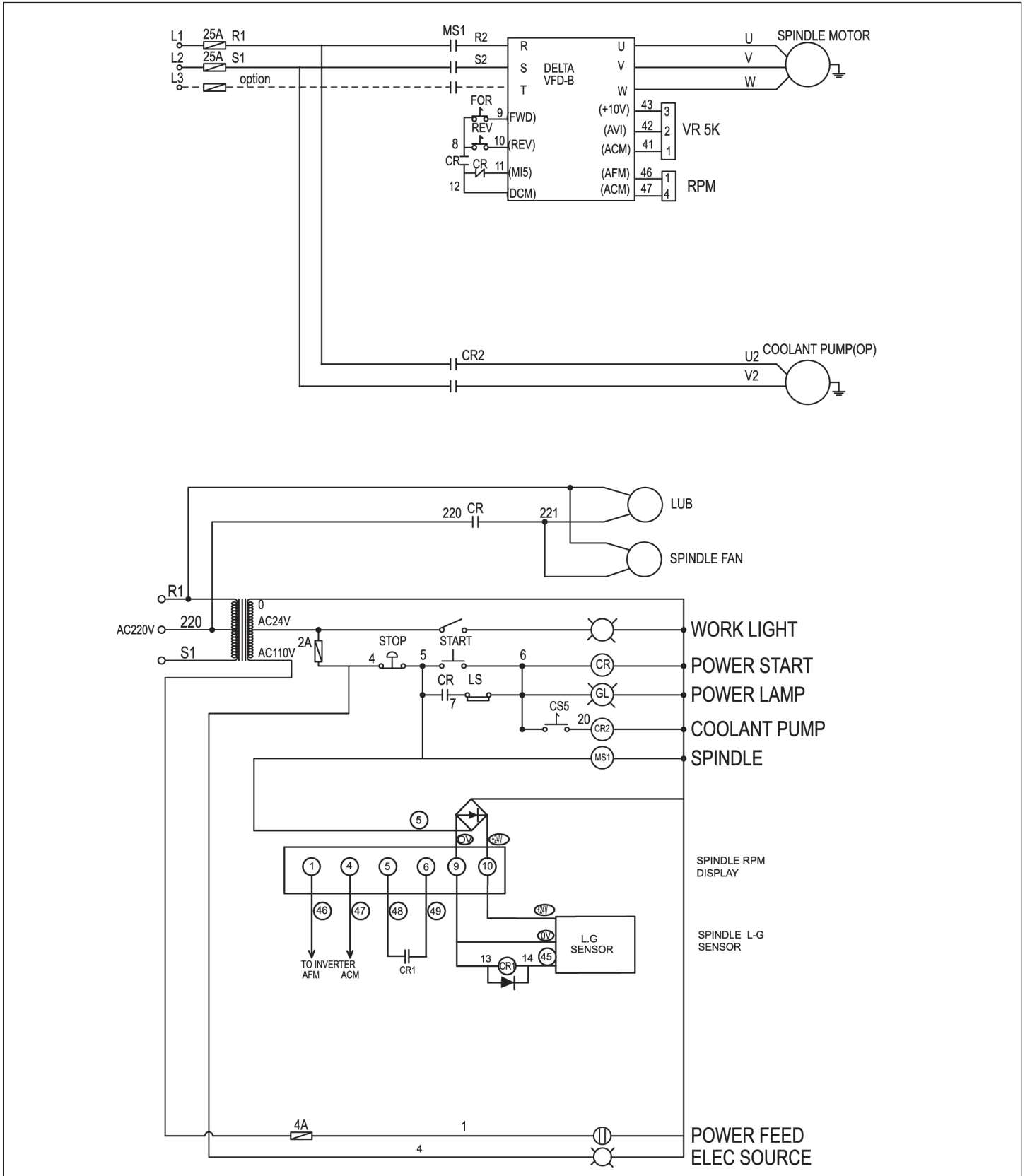

NOTES



NOTES



Trick-Tools.com

75 Truman Road
Pella, IA 50219

Phone: 1-877-VAN-SANT
E-mail: sales@trick-tools.com

