



OPERATOR'S MANUAL

Metal Working



ROTARY DRAW BENDER MODEL: MPB-275

Baileigh Industrial, Inc.
P.O. Box 531
Manitowoc, WI 54221-0531
Phone: 920.684.4990
Fax: 920.684.3944
sales@baileigh.com

REPRODUCTION OF THIS MANUAL IN ANY FORM WITHOUT WRITTEN APPROVAL OF BAILEIGH INDUSTRIAL, INC. IS PROHIBITED. Baileigh Industrial, Inc. does not assume and hereby disclaims any liability for any damage or loss caused by an omission or error in this Operator's Manual, resulting from accident, negligence, or other occurrence.



Table of Contents

THANK YOU & WARRANTY	1
INTRODUCTION.....	3
GENERAL NOTES.....	3
SAFETY INSTRUCTIONS	4
SAFETY PRECAUTIONS	7
Dear Valued Customer:.....	7
TECHNICAL SPECIFICATIONS.....	9
TECHNICAL SUPPORT	9
UNPACKING AND CHECKING CONTENTS.....	10
Cleaning	10
TRANSPORTING AND LIFTING	11
INSTALLATION.....	11
ASSEMBLY AND SET UP	12
GETTING TO KNOW YOUR MACHINE	13
GENERAL DESIGN DESCRIPTION.....	14
ELECTRICAL.....	15
OPERATION.....	17
Programmer Overview.....	17
Machine Start up and Homing	17
Programmer Display and Key Functions	18
Main Menu Choices.....	18
Delete Program	18
Run Program	18
Manual Bend	18
OEM Menu & Homing (FIG OEM 1 THRU 7)	19
Creating a Program	19
Running a Program	20
Dry Running.....	20
Screen Shots.....	21
Diagram 1	24
Diagram 2	25
UNDERSTANDING SPRINGBACK	26
MATERIAL SELECTION.....	26
Material Insertion.....	27
Material Removal / Advancement.....	28
BENDING GLOSSARY	29
BENDING SUGGESTIONS	30
Aluminum Bending	30
LUBRICATION AND MAINTENANCE	31
Gear Box Oil.....	31
Main Spindle Bearing	31
ELECTRICAL SCHEMATIC.....	32



Electrical Components.....	33
TROUBLESHOOTING	34
ARC LENGTH TABLE.....	35
PARTS DIAGRAM	36
Base Assembly Parts Diagram	36
Gear Box Parts Diagram	37
Top and Bottom Plate Assembly Parts Diagram.....	38
Lead Screw Assembly Parts Diagram	39
Actuator Assembly Parts Diagram.....	40
Spiral Bend Plate Counter Die Assembly Parts Diagram	41
Pivot Pin Assembly Parts Diagram	42
Roller Counter Die Assembly Parts Diagram.....	43
Spiral Bend Plate Assembly Parts Diagram	44
Control Box Assembly Parts Diagram	45
Tool Box Assembly Parts Diagram	46
Parts List	47



THANK YOU & WARRANTY

Thank you for your purchase of a machine from Baileigh Industrial. We hope that you find it productive and useful to you for a long time to come.

Inspection & Acceptance. Buyer shall inspect all Goods within ten (10) days after receipt thereof. Buyer's payment shall constitute final acceptance of the Goods and shall act as a waiver of the Buyer's rights to inspect or reject the goods unless otherwise agreed. If Buyer rejects any merchandise, Buyer must first obtain a Returned Goods Authorization ("RGA") number before returning any goods to Seller. Goods returned without a RGA will be refused. Seller will not be responsible for any freight costs, damages to goods, or any other costs or liabilities pertaining to goods returned without a RGA. Seller shall have the right to substitute a conforming tender. Buyer will be responsible for all freight costs to and from Buyer and repackaging costs, if any, if Buyer refuses to accept shipment. If Goods are returned in unsalable condition, Buyer shall be responsible for full value of the Goods. Buyer may not return any special order Goods. Any Goods returned hereunder shall be subject to a restocking fee equal to 30% of the invoice price.

Specifications. Seller may, at its option, make changes in the designs, specifications or components of the Goods to improve the safety of such Goods, or if in Seller's judgment, such changes will be beneficial to their operation or use. Buyer may not make any changes in the specifications for the Goods unless Seller approves of such changes in writing, in which event Seller may impose additional charges to implement such changes.

Limited Warranty. Seller warrants to the original end-user that the Goods manufactured or provided by Seller under this Agreement shall be free of defects in material or workmanship for a period of twelve (12) months from the date of purchase, provided that the Goods are installed, used, and maintained in accordance with any instruction manual or technical guidelines provided by the Seller or supplied with the Goods, if applicable. The original end-user must give written notice to Seller of any suspected defect in the Goods prior to the expiration of the warranty period. The original end-user must also obtain a RGA from Seller prior to returning any Goods to Seller for warranty service under this paragraph. Seller will not accept any responsibility for Goods returned without a RGA. The original end-user shall be responsible for all costs and expenses associated with returning the Goods to Seller for warranty service. In the event of a defect, Seller, at its sole option, shall repair or replace the defective Goods or refund to the original end-user the purchase price for such defective Goods. Goods are not eligible for replacement or return after a period of 30 days from date of receipt. The foregoing warranty is Seller's sole obligation, and the original end-user's exclusive remedy, with regard to any defective Goods. This limited warranty does not apply to: (a) die sets, tooling, and saw blades; (b) periodic or routine maintenance and setup, (c) repair or replacement of the Goods due to normal wear and tear, (d) defects or damage to the Goods resulting from misuse, abuse, neglect, or accidents, (e) defects or damage to the Goods resulting from improper or unauthorized alterations, modifications, or changes; and (f) any Goods that has not been installed and/or maintained in accordance with the instruction manual or technical guidelines provided by Seller.

EXCLUSION OF OTHER WARRANTIES. THE FOREGOING LIMITED WARRANTY IS IN LIEU OF ALL OTHER WARRANTIES, EXPRESS OR IMPLIED. ANY AND ALL OTHER EXPRESS, STATUTORY OR IMPLIED WARRANTIES, INCLUDING BUT NOT LIMITED TO, ANY WARRANTY OF MERCHANTABILITY OR FITNESS FOR ANY PARTICULAR PURPOSE ARE EXPRESSLY DISCLAIMED. NO WARRANTY IS MADE WHICH EXTENDS BEYOND THAT WHICH IS EXPRESSLY CONTAINED HEREIN.

Limitation of Liability. IN NO EVENT SHALL SELLER BE LIABLE TO BUYER OR ANY OTHER PARTY FOR ANY INCIDENTAL, CONSEQUENTIAL OR SPECIAL DAMAGES (INCLUDING, WITHOUT LIMITATION, LOST PROFITS OR DOWN TIME) ARISING FROM OR IN MANNER CONNECTED WITH THE GOODS, ANY BREACH BY SELLER OR ITS AGENTS OF THIS AGREEMENT, OR ANY OTHER CAUSE WHATSOEVER, WHETHER BASED ON CONTRACT, TORT OR ANY OTHER THEORY OF LIABILITY. BUYER'S REMEDY WITH RESPECT TO ANY CLAIM ARISING UNDER THIS AGREEMENT IS STRICTLY LIMITED TO NO MORE THAN THE AMOUNT PAID BY THE BUYER FOR THE GOODS.



Force Majeure. Seller shall not be responsible for any delay in the delivery of, or failure to deliver, Goods due to causes beyond Seller's reasonable control including, without limitation, acts of God, acts of war or terrorism, enemy actions, hostilities, strikes, labor difficulties, embargoes, non-delivery or late delivery of materials, parts and equipment or transportation delays not caused by the fault of Seller, delays caused by civil authorities, governmental regulations or orders, fire, lightening, natural disasters or any other cause beyond Seller's reasonable control. In the event of any such delay, performance will be postponed by such length of time as may be reasonably necessary to compensate for the delay.

Installation. If Buyer purchases any Goods that require installation, Buyer shall, at its expense, make all arrangements and connections necessary to install and operate the Goods. Buyer shall install the Goods in accordance with any Seller instructions and shall indemnify Seller against any and all damages, demands, suits, causes of action, claims and expenses (including actual attorneys' fees and costs) arising directly or indirectly out of Buyer's failure to properly install the Goods.

Work By Others; Safety Devices. Unless agreed to in writing by Seller, Seller has no responsibility for labor or work performed by Buyer or others, of any nature, relating to design, manufacture, fabrication, use, installation or provision of Goods. Buyer is solely responsible for furnishing, and requiring its employees and customers to use all safety devices, guards and safe operating procedures required by law and/or as set forth in manuals and instruction sheets furnished by Seller. Buyer is responsible for consulting all operator's manuals, ANSI or comparable safety standards, OSHA regulations and other sources of safety standards and regulations applicable to the use and operation of the Goods.

Remedies. Each of the rights and remedies of Seller under this Agreement is cumulative and in addition to any other or further remedies provided under this Agreement or at law or equity.

Attorney's Fees. In the event legal action is necessary to recover monies due from Buyer or to enforce any provision of this Agreement, Buyer shall be liable to Seller for all costs and expenses associated therewith, including Seller's actual attorneys' fees and costs.

Governing Law/Venue. This Agreement shall be construed and governed under the laws of the State of Wisconsin, without application of conflict of law principles. Each party agrees that all actions or proceedings arising out of or in connection with this Agreement shall be commenced, tried, and litigated only in the state courts sitting in Manitowoc County, Wisconsin or the U.S. Federal Court for the Eastern District of Wisconsin. Each party waives any right it may have to assert the doctrine of "forum non conveniens" or to object to venue to the extent that any proceeding is brought in accordance with this section. Each party consents to and waives any objection to the exercise of personal jurisdiction over it by courts described in this section. Each party waives to the fullest extent permitted by applicable law the right to a trial by jury.

Summary of Return Policy.

- 10 Day acceptance period from date of delivery. Damage claims and order discrepancies will not be accepted after this time.
- You must obtain a Baileigh issued RGA number PRIOR to returning any materials.
- Returned materials must be received at Baileigh in new condition and in original packaging.
- Altered items are not eligible for return.
- Buyer is responsible for all shipping charges.
- A 30% re-stocking fee applies to all returns.

Baileigh Industrial makes every effort to ensure that our posted specifications, images, pricing and product availability are as correct and timely as possible. We apologize for any discrepancies that may occur. Baileigh Industrial reserves the right to make any and all changes deemed necessary in the course of business including but not limited to pricing, product specifications, quantities, and product availability.

For Customer Service & Technical Support:

Please contact one of our knowledgeable Sales and Service team members at:
(920) 684-4990 or e-mail us at sales@baileighindustrial.com



INTRODUCTION

The quality and reliability of the components assembled on a Baileigh Industrial machine guarantee near perfect functioning, free from problems, even under the most demanding working conditions. However if a situation arises, refer to the manual first. If a solution cannot be found, contact the distributor where you purchased our product. Make sure you have the serial number and production year of the machine (stamped on the nameplate). For replacement parts refer to the assembly numbers on the parts list drawings.

Our technical staff will do their best to help you get your machine back in working order.

In this manual you will find: (when applicable)

- Safety procedures
- Correct installation guidelines
- Description of the functional parts of the machine
- Capacity charts
- Set-up and start-up instructions
- Machine operation
- Scheduled maintenance
- Parts lists

GENERAL NOTES

After receiving your equipment remove the protective container. Do a complete visual inspection, and if damage is noted, **photograph it for insurance claims** and contact your carrier at once, requesting inspection. Also contact Baileigh Industrial and inform them of the unexpected occurrence. Temporarily suspend installation.

Take necessary precautions while loading / unloading or moving the machine to avoid any injuries.

Your machine is designed and manufactured to work smoothly and efficiently. Following proper maintenance instructions will help ensure this. Try and use original spare parts, whenever possible, and most importantly; **DO NOT** overload the machine or make any unauthorized modifications.



Note: This symbol refers to useful information throughout the manual.



IMPORTANT **PLEASE READ THIS OPERATORS MANUAL CAREFULLY**

It contains important safety information, instructions, and necessary operating procedures. The continual observance of these procedures will help increase your production and extend the life of the equipment.

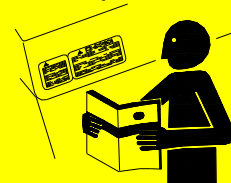

SAFETY INSTRUCTIONS

LEARN TO RECOGNIZE SAFETY INFORMATION

This is the safety alert symbol. When you see this symbol on your machine or in this manual, **BE ALERT TO THE POTENTIAL FOR PERSONAL INJURY!**



Follow recommended precautions and safe operating practices.

UNDERSTAND SIGNAL WORDS

A signal word – **DANGER**, **WARNING**, or **CAUTION** is used with the safety alert symbol. **DANGER** identifies a hazard or unsafe practice that will result in severe **Injury or Death**.



Safety signs with signal word **DANGER** or **WARNING** are typically near specific hazards.



General precautions are listed on **CAUTION** safety signs. **CAUTION** also calls attention to safety messages in this manual.





SAVE THESE INSTRUCTIONS.
Refer to them often and use them to instruct others.



PROTECT EYES

Wear safety glasses or suitable eye protection when working on or around machinery.

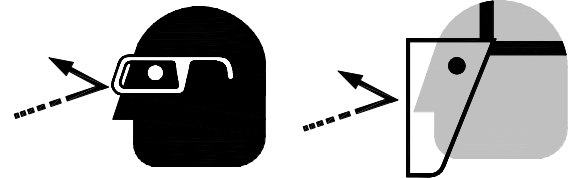

PROTECT AGAINST NOISE

Prolonged exposure to loud noise can cause impairment or loss of hearing. Wear suitable hearing protective devices such as ear muffs or earplugs to protect against objectionable or uncomfortable loud noises.



BEWARE OF CRUSH HAZARD

NEVER place your hands, fingers, or any part of your body in the die area of this machine. Be aware of the area on either side of the dies for crush points created by material movement.

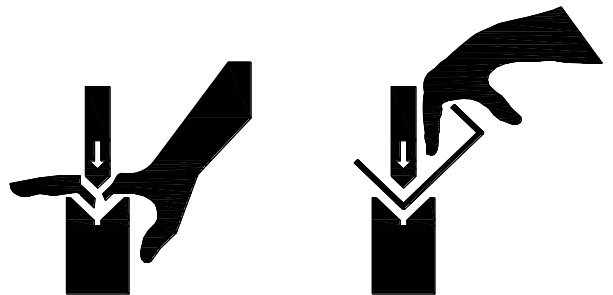

BEWARE OF PINCH POINTS

Keep hands and fingers away from the drive mechanisms, cylinders, ratchets, and other moving linkage while the machine is in operation.

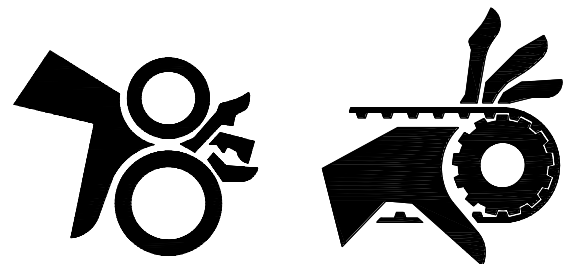



KEEP CLEAR OF MOVING OBJECTS

Always be aware of the position of the material and the swing area in which the material will travel. The material will swing with significant force. This swing area will create pinch points and the force of the material movement may cause serious bodily injuries.



HYDRAULIC HOSE FAILURE

Exercise **CAUTION** around hydraulic hoses in case of a hose or fitting failure.

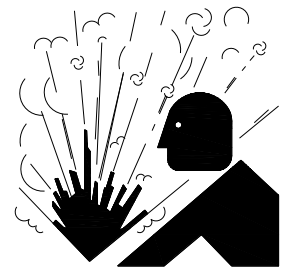

HIGH VOLTAGE

USE CAUTION IN HIGH VOLTAGE AREAS. DO NOT assume the power to be off.
FOLLOW PROPER LOCKOUT PROCEDURES.

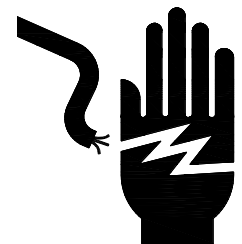



SAFETY PRECAUTIONS



Metal working can be dangerous if safe and proper operating procedures are not followed. As with all machinery, there are certain hazards involved with the operation of the product. Using the machine with respect and caution will considerably lessen the possibility of personal injury. However, if normal safety precautions are overlooked or ignored, personal injury to the operator may result.

Safety equipment such as guards, hold-downs, safety glasses, dust masks and hearing protection can reduce your potential for injury. But even the best guard won't make up for poor judgment, carelessness or inattention. **Always use common sense** and exercise **caution** in the workshop. If a procedure feels dangerous, don't try it.

REMEMBER: Your personal safety is your responsibility.



WARNING: FAILURE TO FOLLOW THESE RULES MAY RESULT IN SERIOUS PERSONAL INJURY

Dear Valued Customer:

- All Baileigh machines should be used only for their intended use.
- Baileigh does not recommend or endorse making any modifications or alterations to a Baileigh machine. Modifications or alterations to a machine may pose a substantial risk of injury to the operator or others and may do substantial damage to the machine.
- Any modifications or alterations to a Baileigh machine will invalidate the machine's warranty.

PLEASE ENJOY YOUR BAILEIGH MACHINE!PLEASE ENJOY IT SAFELY!

1. **Only trained and qualified personnel can operate this machine.**
2. **Make sure guards are in place and in proper working order before operating machinery.**
3. **Remove any adjusting tools.** Before operating the machine, make sure any adjusting tools have been removed.
4. **Keep work area clean.** Cluttered areas invite injuries.
5. **Overloading machine.** By overloading the machine you may cause injury from flying parts. **DO NOT** exceed the specified machine capacities.
6. **Dressing material edges.** Always chamfer and deburr all sharp edges.



7. **Do not force tool.** Your machine will do a better and safer job if used as intended. **DO NOT** use inappropriate attachments in an attempt to exceed the machines rated capacity.
8. **Use the right tool for the job.** **DO NOT** attempt to force a small tool or attachment to do the work of a large industrial tool. **DO NOT** use a tool for a purpose for which it was not intended.
9. **Dress appropriate.** **DO NOT** wear loose fitting clothing or jewelry as they can be caught in moving machine parts. Protective clothing and steel toe shoes are recommended when using machinery. Wear a restrictive hair covering to contain long hair.
10. **Use eye and ear protection.** Always wear ISO approved impact safety goggles. Wear a full-face shield if you are producing metal filings.
11. **Do not overreach.** Maintain proper footing and balance at all times. **DO NOT** reach over or across a running machine.
12. **Stay alert.** Watch what you are doing and use common sense. **DO NOT** operate any tool or machine when you are tired.
13. **Check for damaged parts.** Before using any tool or machine, carefully check any part that appears damaged. Check for alignment and binding of moving parts that may affect proper machine operation.
14. **Observe work area conditions.** **DO NOT** use machines or power tools in damp or wet locations. Do not expose to rain. Keep work area well lighted. **DO NOT** use electrically powered tools in the presence of flammable gases or liquids.
15. **Keep children away.** Children must never be allowed in the work area. **DO NOT** let them handle machines, tools, or extension cords.
16. **Store idle equipment.** When not in use, tools must be stored in a dry location to inhibit rust. Always lock up tools and keep them out of reach of children.
17. **DO NOT operate machine if under the influence of alcohol or drugs.** Read warning labels on prescriptions. If there is any doubt, **DO NOT** operate the machine.
18. **DO NOT** touch live electrical components or parts.
19. **Turn off** power before checking, cleaning, or replacing any parts.
20. Be sure **all** equipment is properly installed and grounded according to national, state, and local codes.
21. **DO NOT** bypass or defeat any safety interlock systems.
22. Keep visitors a safe distance from the work area.



TECHNICAL SPECIFICATIONS

Solid Square Capacity	1" x 1" (25.4 x 25.4mm)
Solid Round Capacity	1" (25.4mm)
Flat Bar Stock Capacity	1/2" x 2" (12.7 x 50.8mm) Easy Way
Pipe Schedule 40	1-1/4" (31.75mm)
Bend Direction	Bi-Directional
Max. RPM	6 RPM
Maximum Bend Speed	5 second 180 degree
Degree of Bend (Max)	9999°
Power	208-240 VAC, 20A, 1ph, 60Hz
Sound level	<70db
Shipping Weight	750lbs. (340kg)
Shipping Dimensions	60" x 44" x 68" (1524 x 1118 x 1727mm)
Based on a material tensile strength of *64000 PSI – mild steel	
**100000 PSI – stainless steel	

Includes

- Bend pins (2" tall) - 3.0 ir, 2.5 ir, 2.0 ir, 1.5 ir, 1.25, 1.0, 0.625 ir.
- Universal bending plate with 4 hardened lock pins includes tight nose bending tool.
- Roller bending tool.
- One rotating stop and one fixed stop with adapter to run standard dies and counter dies.
- 4 shear pins.

TECHNICAL SUPPORT

Our technical support department can be reached at 920.684.4990, and asking for the support desk for purchased machines. Tech Support handles questions on machine setup, schematics, warranty issues, and individual parts needs: (other than die sets and blades).

For specific application needs or future machine purchases contact the Sales Department at: sales@baileighindustrial.com, Phone: 920.684.4990, or Fax: 920.684.3944.



Note: The photos illustrations used in this manual are representative only and may not depict the actual color, labeling or accessories and may be intended to illustrate technique only.



Note: The specifications and dimensions presented here are subject to change without prior notice due to improvements of our products.



UNPACKING AND CHECKING CONTENTS

Your Baileigh machine is shipped complete in one crate. Separate all parts from the packing material and check each item carefully. Make certain all items are accounted for before discarding any packing material.

⚠ WARNING: SUFFOCATION HAZARD! Immediately discard any plastic bags and packing materials to eliminate choking and suffocation hazards to children and animals.
If any parts are missing, do not plug in the power cable, or turn the power switch on until the missing parts are obtained and installed correctly.

Cleaning

Your machine may be shipped with a rustproof waxy oil coating and grease on the exposed unpainted metal surfaces. To remove this protective coating, use a degreaser or solvent cleaner. For a more thorough cleaning, some parts will occasionally have to be removed. **DO NOT USE** acetone or brake cleaner as they may damage painted surfaces. Follow manufacturer's label instructions when using any type of cleaning product. After cleaning, wipe unpainted metal surfaces with a light coating of quality oil or grease for protection.

⚠ WARNING: DO NOT USE gasoline or other petroleum products to clean the machine. They have low flash points and can explode or cause fire.

⚠ CAUTION: When using cleaning solvents work in a well-ventilated area. Many cleaning solvents are toxic if inhaled.





TRANSPORTING AND LIFTING

⚠ CAUTION: Lifting and carrying operations should be carried out by skilled workers, such as a truck operator. Make sure the machine is well balanced. Choose a location that will keep the machine free from vibration and dust from other machinery. Keep in mind that having a large clearance area around the machine is important for safe and efficient working conditions.

Follow these guidelines when lifting:

- The lift truck must be able to lift at least 1.5 – 2 times the machines gross weight.
- Make sure the machine is balanced. While transporting, avoid rough or jerky motion, and maintain a safe clearance zone around the transport area.
- Use a fork lift with sufficient lifting capacity and forks that are long enough to reach the complete width of the machine.
- Remove the securing bolts that attach the machine to the pallet.
- Approaching the machine from the side, lift the machine on the frame taking care that there are no cables or pipes in the area of the forks.
- Move the machine to the required position and lower gently to the floor.
- Level the machine so that all the supporting feet are taking the weight of the machine and no rocking is taking place.

INSTALLATION

IMPORTANT:

Consider the following when looking for a suitable location to place the machine:

- Overall weight of the machine.
- Weight of material being processed.
- Sizes of material to be processed through the machine.
- Space needed for auxiliary stands, work tables, or other machinery.
- Clearance from walls and other obstacles.
- Maintain an adequate working area around the machine for safety.
- Have the work area well illuminated with proper lighting.



- Keep the floor free of oil and make sure it is not slippery.
- Remove scrap and waste materials regularly, and make sure the work area is free from obstructing objects.
- If long lengths of material are to be fed into the machine, make sure that they will not extend into any aisles.
- **LEVELING:** The machine should be sited on a level, concrete floor. For stationary machines, provisions for securing it should be in position prior to placing the machine. The accuracy of any machine depends on the precise placement of it to the mounting surface.
- **FLOOR:** This tool distributes a large amount of weight over a small area. Make certain that the floor is capable of supporting the weight of the machine, work stock, and the operator. The floor should also be a level surface. If the unit wobbles or rocks once in place, be sure to eliminate by using shims.
- **WORKING CLEARANCES:** Take into consideration the size of the material to be processed. Make sure that you allow enough space for you to operate the machine freely.
- **POWER SUPPLY PLACEMENT:** The power supply should be located close enough to the machine so that the power cord is not in an area where it would cause a tripping hazard. Be sure to observe all electrical codes if installing new circuits and/or outlets.

ASSEMBLY AND SET UP

 **WARNING:** For your own safety, **DO NOT** connect the machine to the power source until the machine is completely assembled and you read and understand the entire instruction manual.

1. Remove the machine from the skid it was shipped on and install the casters.
2. Check the oil level and top off if necessary.
3. Read through the remainder of the manual and become familiar with the die installation and settings as well as normal operation.
4. Position the machine as desired following the installation guidelines.
5. Follow the electrical guidelines to connect the machine to a power supply.



GETTING TO KNOW YOUR MACHINE





Item	Description	Function
A	Grease Zerk	For greasing main spindle bearing
B	Main Spindle And Drive Pins	For supporting the bend plate and bending pins
C	Center Pin	For aligning die onto spindle
D	Counter Die Assembly	Supports and feeds the material into the bending area.
E	Release Actuator	For moving the counter die assembly away from the bending plate to remove and insert material quickly
F	Numerical Counter	For indicating counter die position. Aids in repeatability.
G	Touch Screen Controller	For programming bend data
H	3 Legged Handwheel	For adjusting counter die position
I	Main Disconnect Switch	For turning power on/off
J	Push Handle	For maneuvering machine on its wheels
K	Power Cord	For connecting to main power source
L	Foot Pedal Guard	Protect against accidental operation
M	Forward Foot Pedal	Will operate the machine in the cw direction.
N	Reverse Foot Pedal	Will operate the machine in the ccw direction.

GENERAL DESIGN DESCRIPTION

You have made a practical choice in purchasing the MPB-275 Fully Programmable Bending Machine. It has been carefully built of high quality materials and designed to give many years of efficient service. The simplicity of design and minimum effort required to operate the machine contributes towards meeting schedules and producing greater profits.

The MPB-275 is an electric powered “Rotary Draw” bending machine. To bend material, bending pins (sometimes called dies) are mounted on the bending plate and counter die are required. The material is hooked by the bending pins and is powerfully rotated in the clockwise or counter-clockwise direction. As the bending plate rotates, the counter die remains stationary, forcing the material to conform to the radius and shape of the bending pin arrangement.

The MPB-275 Bending Machine you have purchased is built of solid steel ensuring maximum rigidity. Tongue and groove design with grade 8 bolts throughout provides very high rigidity and stability.

Throughout this manual are listed various safety-related descriptions for attention. These matters for attention contain the essential information to the operators while operating, and maintaining. Failure to follow these instructions may result in great damage to the machine or injury to the operator.



ELECTRICAL

⚠ CAUTION: HAVE ELECTRICAL UTILITIES CONNECTED TO MACHINE BY A CERTIFIED ELECTRICIAN!
Check if the available power supply is the same as listed on the machine nameplate.

⚠ WARNING: Make sure the grounding wire (green) is properly connected to avoid electric shock. DO NOT switch the position of the green grounding wire if any electrical plug wires are switched during hookup.

Motor Specifications

Your tool is wired for 220 volt, 60Hz alternating current. Before connecting the tool to the power source, make sure the machine is cut off from power source.

Considerations

- Observe local electrical codes when connecting the machine.
- The circuit should be protected with a time delay fuse or circuit breaker with a amperage rating slightly higher than the full load current of machine.
- A separate electrical circuit should be used for your tools. Before connecting the motor to the power line, make sure the switch is in the "OFF" position and be sure that the electric current is of the same characteristics as indicated on the tool.
- All line connections should make good contact. Running on low voltage will damage the motor.
- In the event of a malfunction or breakdown, grounding provides a path of least resistance for electric current to reduce the risk of electric shock. This tool is equipped with an electric cord having an equipment-grounding conductor and a grounding plug. The plug must be plugged into a matching outlet that is properly installed and grounded in accordance with all local codes and ordinances.

⚠ WARNING: In all cases, make certain the receptacle in question is properly grounded. If you are not sure, have a qualified electrician check the receptacle.



- Improper connection of the equipment-grounding conductor can result in risk of electric shock. The conductor with insulation having an outer surface that is green with or without yellow stripes is the equipment-grounding conductor. If repair or replacement of the electric cord or plug is necessary, do not connect the equipment-grounding conductor to a live terminal.
- Check with a qualified electrician or service personnel if the grounding instructions are not completely understood, or if in doubt as to whether the tool is properly grounded.
- Repair or replace damaged or worn cord immediately.

Extension Cord Safety

Extension cord should be in good condition and meet the minimum wire gauge requirements listed below:

AMP RATING	LENGTH		
	25ft	50ft	100ft
0-6	16	16	16
7-10	16	16	14
11-12	16	16	14
13-16	14	12	12
17-20	12	12	10
21-30	10	10	No
WIRE GAUGE			

An undersized cord decreases line voltage, causing loss of power and overheating. All cords should use a ground wire and plug pin. Replace any damaged cords immediately.

Power cord connection:

1. Turn the main disconnect switch on the control panel to the OFF position.
2. Unwrap the power cord and route the cord away from the machine toward the power supply.
 - a. Route the power cord so that it will NOT become entangled in the machine in any way.
 - b. Route the cord to the power supply in a way that does NOT create a trip hazard.
3. Connect the power cord to the power supply and check that the power cord has not been damaged during installation.
4. When the machine is clear of any obstruction. The main power switch may be turn ON to test the operation. Turn the switch OFF when the machine is not in operation.



OPERATION

 **CAUTION:** Always wear proper eye protection with side shields, safety footwear, and leather gloves to protect from burrs and sharp edges.

 **CAUTION:** Keep hands and fingers clear of the dies and swing arms. Stand to the front of the machine to avoid getting hit with the material during the bending process. When handling large heavy materials make sure they are properly supported.

Programmer Overview

- This draw bender utilizes a fully programmable touch screen operator interface. The unique operator interface allows you to write and save 140 programs with 10 bends per program. Operation is extremely simple to learn. Simple foot pedal controls allow you to easily produce fast and accurate bends. The following instructions will walk you through the basic functions.
- Be sure to follow the dry running instructions to familiarize yourself with all the functions of the control before any actual bending of material is performed.



Note: See the Screen Shots section near the end of the manual to match the figure call outs.

Machine Start up and Homing

1. Turn the main power switch to the "ON" position
2. It takes about 1 minute for the programmer to boot up. The machine has been homed from the factory and does not need to be re-homed unless the encoder or drive motor needs servicing.
3. The programmer will display the "RMD MAIN SCREEN" see Fig.1 & 2.
4. At this point, the screen in Fig1 or Fig 2 will be displayed, Fig 1 allows only one bend direction, and Fig 2 allows you to choose the bend direction. If the non-standard bend direction is chosen, a Warning screen is displayed Fig 2.2, this is to ensure the proper tooling is chosen for a given bend direction.
5. On the RMD MAIN SCREEN, you can choose "MANUAL MODE" or "RUN, VIEW OR EDIT A PROGRAM"



Programmer Display and Key Functions

1. The touch screen control is very self-explanatory. By touching the labeled touch boxes on the screen, the listed parameter or function will be selected. The exit box will return you to the previous screen and get you back to the RMD MAIN SCREEN. When entering names and degrees, a keypad will be displayed Fig 6.

Main Menu Choices

1. "RUN, VIEW OR EDIT A PROGRAM" Select this Feature if you want to do any of those functions.
 - a. Up to 140 programs with 10 bends per program can be created using any alphanumeric characters.
 - b. To edit a program, choose the program you wish to edit by entering a number or by using the up down arrow keys Fig 7. After selecting the program. Touch the VIEW/EDIT button and the program parameters will be displayed Fig9. Make changes as necessary, press the <F1> key to save any changes.

Delete Program

1. Follow the above steps to get to the edit screen Fig 9 and press and hold the CLEAR PROGRAM button to erase all of the bend data for the selected program.

Run Program

1. Select this feature if you want to run an existing program.
2. To edit a program, choose the program you wish to edit by entering a number or by using the up down arrow keys Fig 7. After selecting the program touch the RUN button and the program parameters will be displayed Fig 11.
3. At this point, pressing the forward foot pedal will start the bending process. The machine will rotate in the selected direction at the chosen speed to the desired degree totaling the bend angle plus the spring back degrees.
4. When at the final position, the control will prompt you to PRESS REV PEDAL TO HOME Fig 12.

Manual Bend

1. Select this feature to bend manually without the need to create a program. The actual degree will be displayed while in this mode. This mode also allows you to enter in one bend angle and on spring back value Fig 3 & 4.
2. With the arrow keys a bend speed from 1-6 can be selected.



OEM Menu & Homing (FIG OEM 1 THRU 7)

1. To set the home position, you must access the OEM screens. Consult the factory for the password.



IMPORTANT: *Don't Change the home position unless you are sure the position was lost, damage to the machine and tooling can occur if the home position is set incorrectly.*

2. Once in the OEM MENU press the HOMING ROUTINE button and follow the directions on the screen to set the home position. The Home position is saved forever even if the power is shut down. You may lose the home position if power is lost to the machine during a move or if wiring or electronics are disconnected inside the electrical cabinet.
3. Activation of bi directional option should only be done at the factory. Consult the factory for specific information.
4. Any other parameters in the OEM MENU should only be done after consulting the factory. Changing these parameters without consulting the factory will void the warranty.

Creating a Program

1. Choose "RUN, VIEW OR EDIT A PROGRAM" from the RMD MAIN SCREEN Fig1.
2. Select a program number from 1 to 140 Fig7.
3. When you reach the desired program number, press, VIEW EDIT Fig 8.
4. On the edit screen enter the desired PROGRAM NAME by touching that field.
5. Enter the bend ANGLE Fig 9.
6. Enter the SPRING BACK Fig 9.
7. Enter the SPEED from 1-6.
8. Enter a COUNTERDIE POSITION (just a reference number taken from the leadscrew counter).
9. Enter a MATERIAL ROTATION if desired.
10. Repeat above steps for Bends #2 to #10.
11. Press the <F1> key to save all data.



Note: *If the ESCAPE key is pressed. The data will be lost.*



Running a Program

1. Choose "RUN, VIEW OR EDIT A PROGRAM" from the RMD MAIN SCREEN Fig1.
2. To edit a program, choose the program you wish to edit by entering a number or by using the up down arrow keys Fig 7. After selecting the program touch the RUN button and the program parameters will be displayed Fig 11.
3. Bend data will be displayed Fig 11.
4. Press and hold the Forward foot pedal down to produce the sample bend.
5. When at the final position, the screen will read, "PRESS REVERSE PEDAL TO HOME Fig 12.
6. Press and hold the reverse foot pedal until the spindle reaches "0" degrees.
7. If a second bend was programmed, this will be the next bend and so on all the way to the last programmed bend up to bend 10.
8. If no data was entered after bend 1, bend 1 will be repeated until escape is pressed.

Dry Running

- Once you are familiar with the machine and programming unit, it is important to dry run a few programs without any tooling or material installed.
- Follow the next steps to produce a generic bend and dry run without material.
- Repeat this process as many times as needed to fully understand the functions and controls.

 **CAUTION: DO NOT ATTEMPT TO OPERATE IF YOU ARE NOT CONFIDENT OR DO NOT UNDERSTAND THE CONTROLS! Feel free to consult the factory with any questions.**



Screen Shots

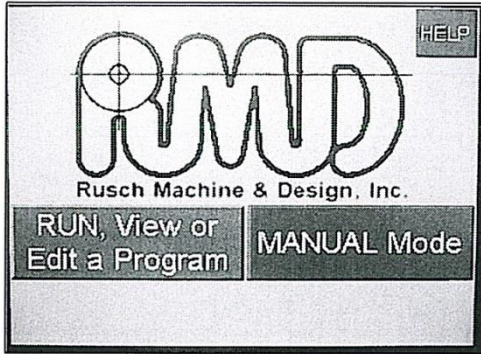

OEM SCREEN FIGURE #1

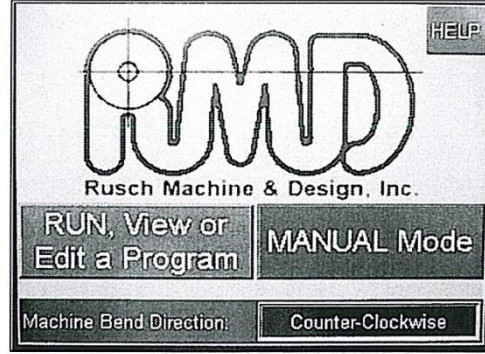

OEM SCREEN FIGURE #2

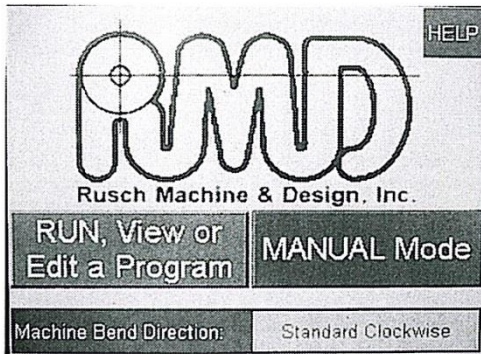

OEM SCREEN FIGURE #2.1

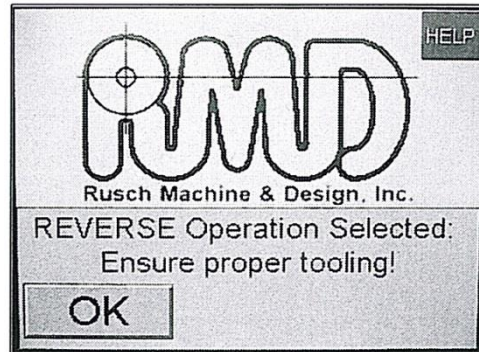

OEM SCREEN FIGURE #2.2

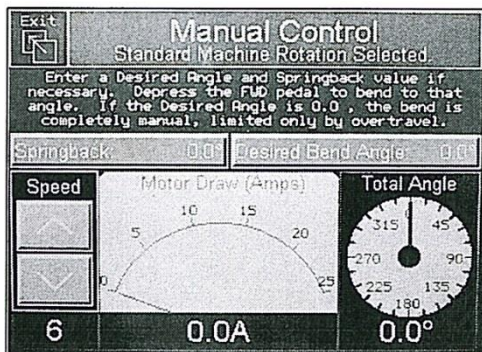

OEM SCREEN FIGURE #3

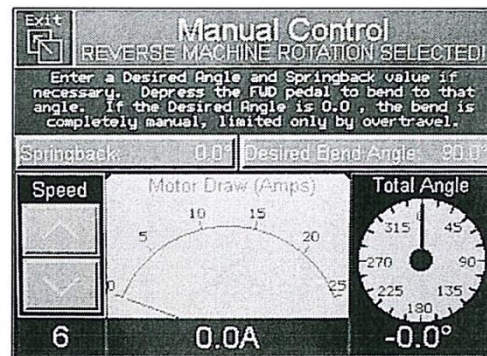

OEM SCREEN FIGURE #4

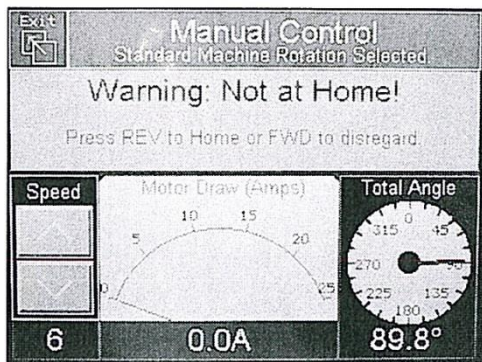

OEM SCREEN FIGURE #5

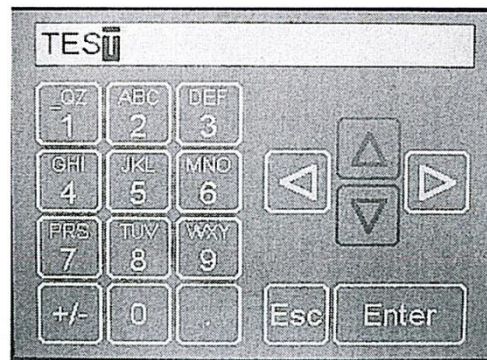

OEM SCREEN FIGURE #6

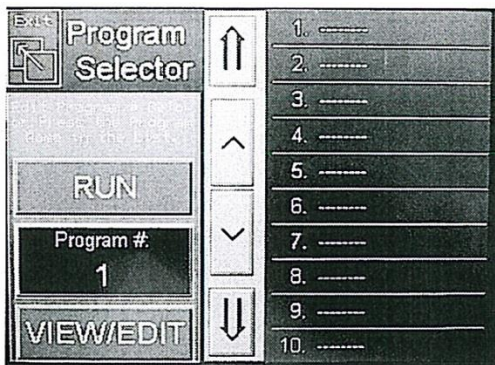

OEM SCREEN FIGURE #7

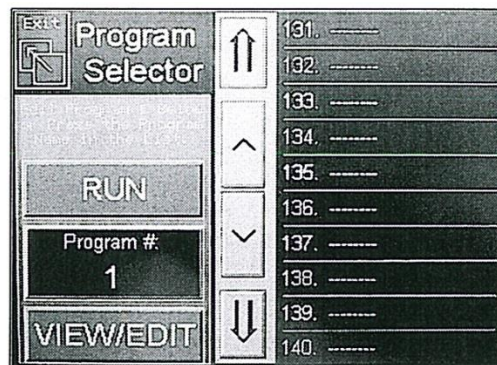

OEM SCREEN FIGURE #8

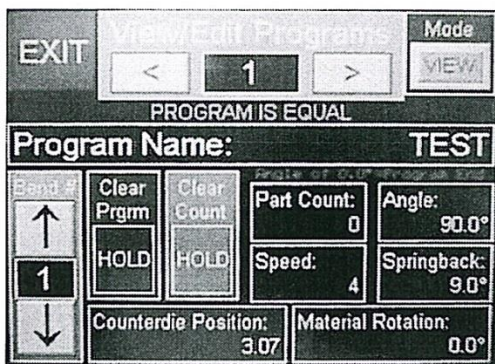

OEM SCREEN FIGURE #9



OEM SCREEN FIGURE #10

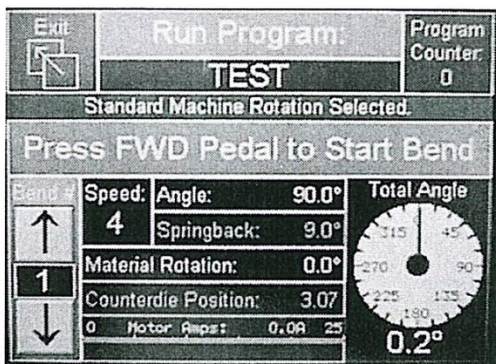

OEM SCREEN FIGURE #11

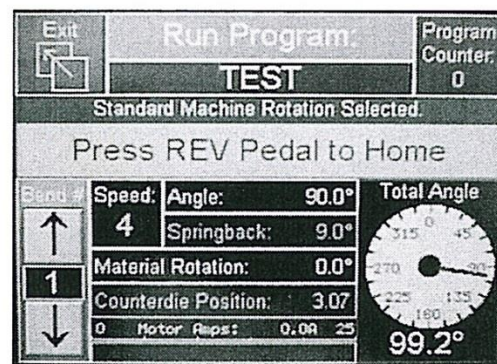

OEM SCREEN FIGURE #12

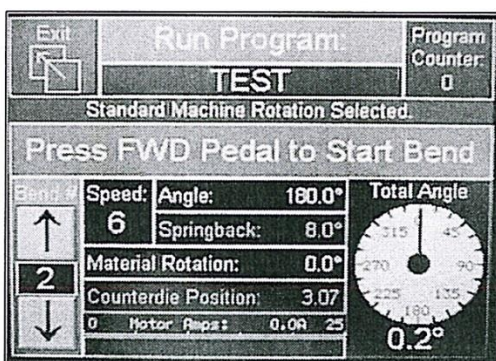

OEM SCREEN FIGURE #13

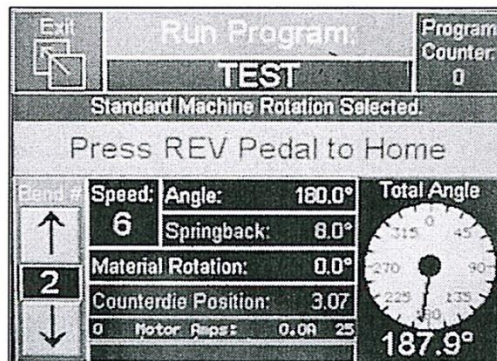

OEM SCREEN FIGURE #14



OEM SCREEN FIGURE #A1

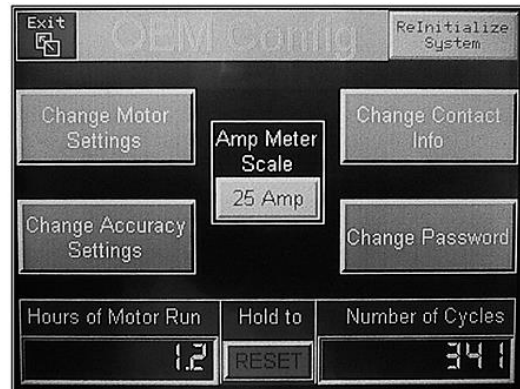

OEM SCREEN FIGURE #A2

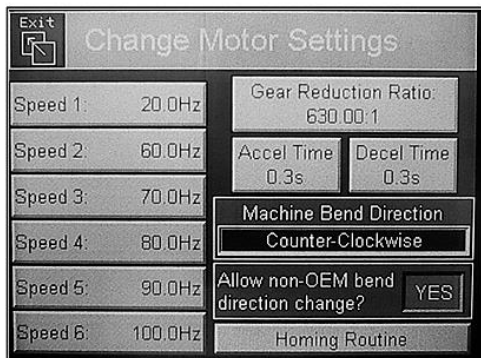

OEM SCREEN FIGURE #A3

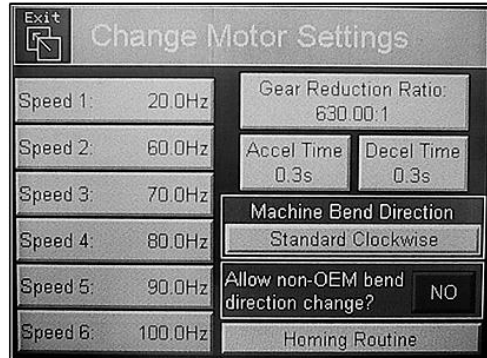

OEM SCREEN FIGURE #A4

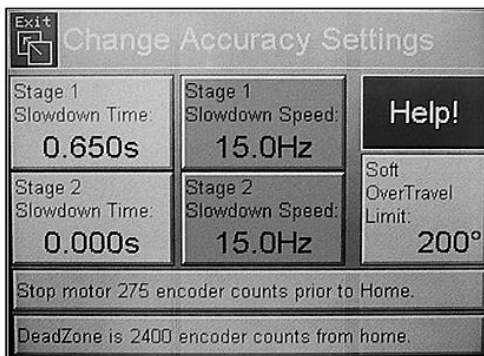

OEM SCREEN FIGURE #A5

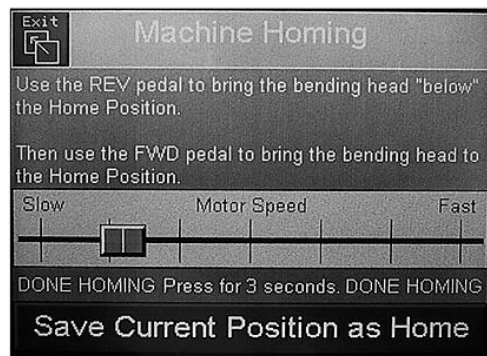

OEM SCREEN FIGURE #A6



OEM SCREEN FIGURE #A7



Diagram 1

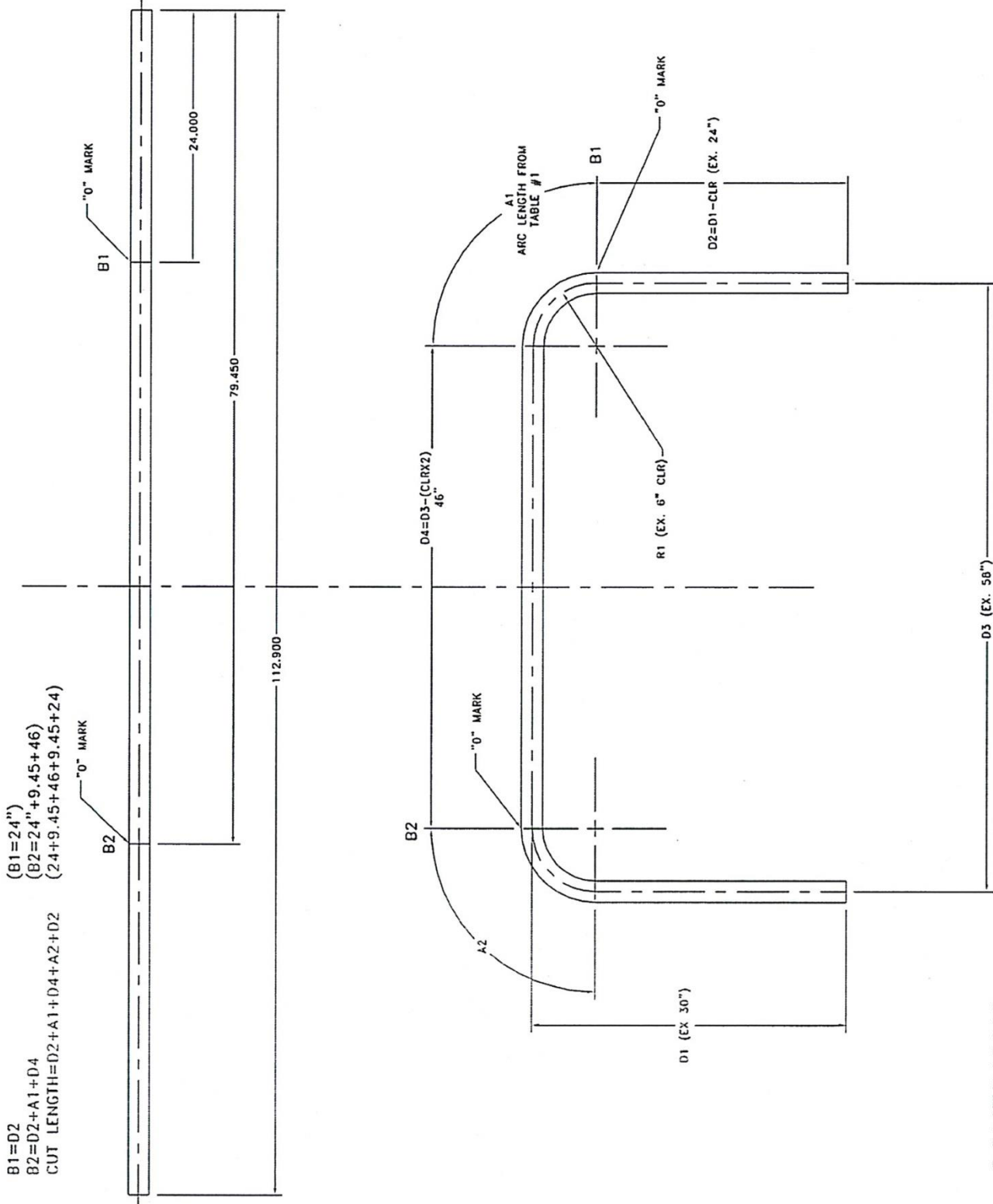

CONTINUOUS LAYOUT

DIAGRAM #1



Diagram 2

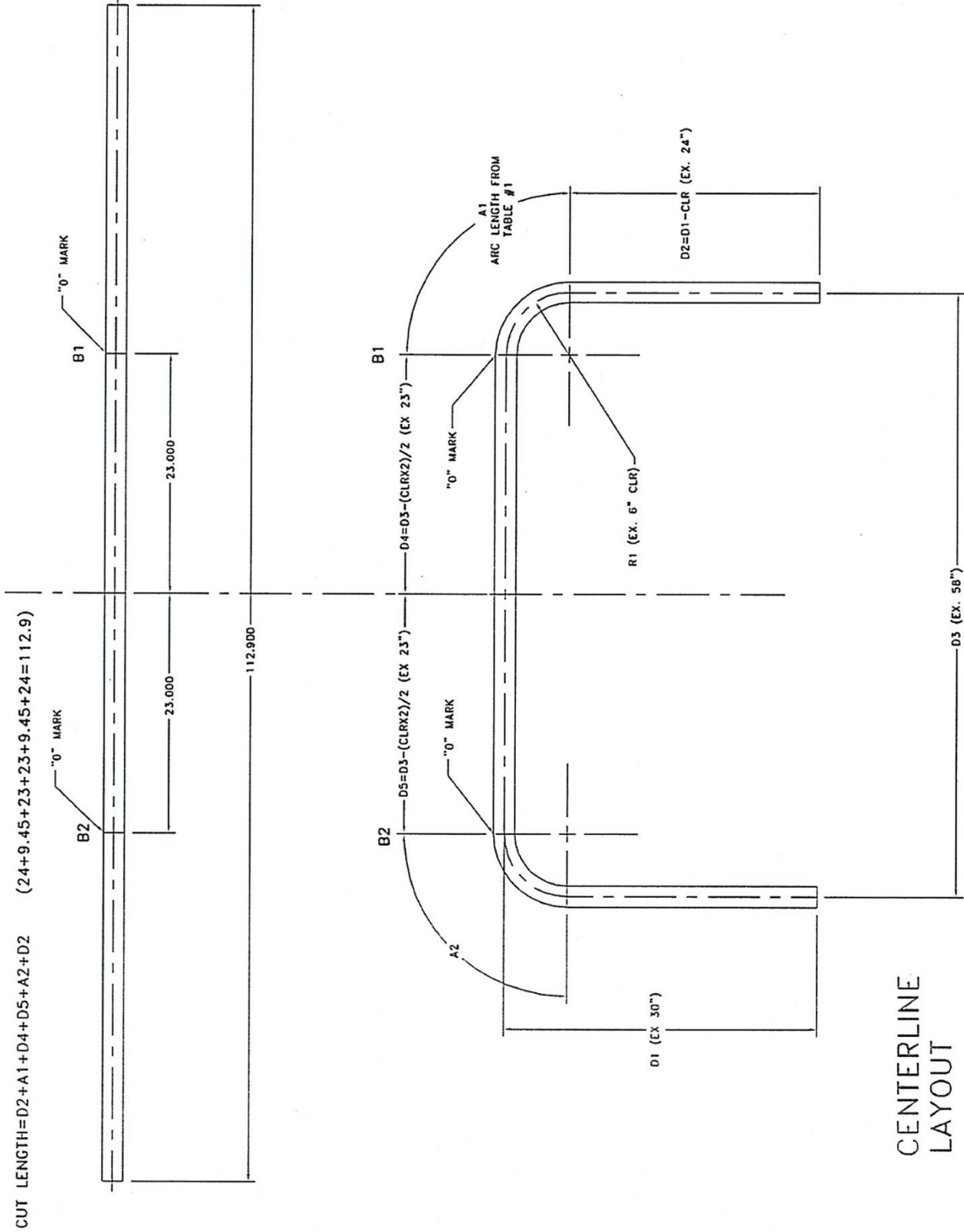

DIAGRAM #2



UNDERSTANDING SPRINGBACK

Springback can be difficult to understand. As material is bent, the materials yield strength resists being formed. As a final degree is reached, the machine will have enough power to hold the bend at a set degree, but as the pressure of the machine is released, the material has a resistance built in, so it “springs back”

Springback will vary with every size, type and wall thickness, so it will never be consistent from size to size.

The best way to determine a materials springback is to do sample bends to 90 degrees until a perfect 90 is obtained.

- At that point document the actual machine degrees.
- Full manual mode is the best place to do these tests.
- Use the overbend amount and enter that value into the springback field.

MATERIAL SELECTION

⚠ CAUTION: It must be determined by the customer that materials being processed through the machine are **NOT** potentially hazardous to operator or personnel working nearby.

When selecting materials keep these instructions in mind:

- Material must be clean and dry. (without oil)
- Material should have a smooth surface so it processes easily.
- Dimensional properties of material must be consistent and not exceed the machine capacity values.
- Chemical structure of material must be consistent.
- Buy certificated steel from the same vendor when possible.



Material Layout

In order to create accurate parts, you will have to layout the material in flat form. First you will need to determine how much material is used per degree of bend. Use the multiplier table on Table #3 to determine the arc lengths for the die in use. Or use the following formula:

Alternate arc length formula:

Example: $6.0 \text{ clr} \times 2 = 12$ $12 \times 3.14 = 37.699$ $37.699 / 360 = 0.1047$ per degree
 $0.1047 \times 90 \text{ degrees} = 9.425$ of material used for a 90 degree bend.

Once the arc lengths are determined you can begin layout of the material using Diagram #1 as a reference.

- Diagram #1 shows a simple part bent on the same plane in the same direction.
- Diagram #2 shows bending based off of a centerline in two directions.
- For symmetrical bends, centerline bending is easiest.
- For non-symmetrical bends, continuous one direction bending is best.

- Another way to layout material is to draw them in a 2D computer software program like Auto Cad. There are many free programs on the internet. In a 2D program you will draw the parts centerline only with corresponding clr's. Then you will be able to list individual segments of the bent part. This data can be directly entered into the control.
- Another program available is BEND-TECH which is a program specifically designed for tube bending and will give you all of the required data to make a part. This software is available from Baileigh Industrial.
- Bending with a rotary draw bender requires determining the start of bend point which will line up with the "0" mark on the die. The portion of the tube toward the hook arm will be locked to the die, the portion toward the counter die is the draw side and will slide along the counter die and conform to the dies shape/radius.

Material Insertion

1. At the RMD main menu, choose "Run/ View Edit" button and choose program to run following the on screen instructions.
2. Once the die set is properly installed and the desired program is loaded and performs as needed, the correct size material can now be inserted.
3. Lubricating counterdie and insert the material to start bending.
4. With the die head at home or "0" position, insert material past the hook arm aligning the "0" mark on the die with where the bend will start on the material.



Important: Liberally apply lubricant along the 1/2 of the material on the side toward and contacts with the counterdie with a WD-40 style lubricant or equivalent. Do not lubricate the bending pins beyond rust prevention. Lubricating the bending pins will encourage slipping of material in the bending pins.

5. Tighten the counter die assembly applying moderate pressure on the material.
6. With the counter die tight, document the number displayed on the Leadscrew counter, you will want to return to the same exact number every time to ensure exact counter die positioning and repeatable bends. This number can be entered in the control for programmed bends.

Leadscrew counter, document this position in the controller.

7. Be sure there are no obstructions along the draw side of the material.
8. Be sure to leave enough material past the counter die roller to produce the desired bend.



Material Removal / Advancement

1. After the die stops at the desired angle, the material needs to be removed or advanced.
2. Activate the reverse foot pedal. As the die starts going backwards, the tension on the counter die assembly will be relieved allowing for easy material removal.
3. Activate the Reverse foot pedal and hold until the die reaches its home or "0" position. If you are advancing the material, open the counter die and then reverse machine, holding the material in place. Be careful when reversing with material still in die, not to catch it on the hook arm of the die. Once the die is at the home position, the material can be removed or advanced.
4. Repeat previous steps for next bend in line.



BENDING GLOSSARY

Arc Length	The length of material along the centerline of the tubing
Centerline Radius (CLR)	Distance in inches from the center of curvature to the centerline axis of the tube bending or pipe bending bends. Abbreviated as CLR. See Tube Bending and Pipe Bending Diagram
Degree	Angle in degrees to which the tube/pipe bends are formed (i.e. 45 degrees, 90 degrees, 180 degrees, etc.)
Easy Way (EW)	Bending of a rectangular tube with its short side in the plane of the tube or pipe bend
Hard Way (HW)	Bending of a rectangular tube with its long side in the plane of the tube or pipe bend
I.D.	Inside diameter of the tube or pipe bends
Minimum Tangent	The minimum straight on the end of pipe bends required by the bending machine to form the bend
Neutral Axis	That portion of the pipe or tube that is neither in compression or tension.
O.D.	Outside diameter in inches of the tube or pipe
Out of Plane	The deviation of the horizontal plane of a single pipe bend between its tangent points, based on the theoretical center-line of the pipe bend
Ovality	The distortion or flattening of pipe or tube from its normal, round shape caused by the pipe bending process
Springback	Amount of degrees material will return after bending pressure is released
Tangent	The straight portion of material on either side of arc of bending bends. See Tube Bending and Pipe Bending Diagrams.
Tangent Point	The point at which the bend starts or ends. See Tube Bending and Pipe Bending Diagrams.
Wall	The thickness in inches of tubular pipe bending material.
Wrinkles	Waving or corrugation of pipe bending bends in the inner radius.



BENDING SUGGESTIONS

Aluminum Bending

If bending aluminum, lubrication is very important, if the results are less than desirable with WD-40 other lubricants can be used such as:

- Johnson Paste Wax (seems to work the best)
- High Pressure grease
- Highly rich dish soap
- The bronze counter die must be polished and have no aluminum deposits or it will continue to pick up metal.
- If using BAILEIGH INDUSTRIAL's standard counterdie is not producing desired results, roller counter dies are also available.
- BAILEIGH INDUSTRIAL has both steel rollers as well as plastic rollers. Plastic rollers are used primarily for polished aluminum. Steel rollers would be used for non-polished materials.
- Some aluminum will crack as it is being bent, 6061-T6 is very hard and may need to be annealed or ordered in the "T-0" condition. Aluminum will age harden so if possible try to get freshly run material.



LUBRICATION AND MAINTENANCE



WARNING: Make sure the electrical disconnect is OFF before working on the machine.

Maintenance should be performed on a regular basis by qualified personnel.

Always follow proper safety precautions when working on or around any machinery.

- Check daily for any unsafe conditions and fix immediately.
- Check that all nuts and bolts are properly tightened.
- On a weekly basis clean the machine and the area around it.
- Lubricate threaded components and sliding devices.
- Apply rust inhibitive lubricant to all non-painted surfaces.



Note: *Proper maintenance can increase the life expectancy of your machine.*

Gear Box Oil

The main Planetary Gear Box is lubed with 80W90 gear lube. Check and replace the gear lube every 3 years or 200hrs of continuous use.

Main Spindle Bearing

The only grease fitting on the bender is the main spindle bearing zerk fitting. Pump with 3-4 shots every month or 10hrs of continuous use.



ELECTRICAL SCHEMATIC

Horner (XLE or XLT)
Hexle 102 or HE-XT102
Programmer

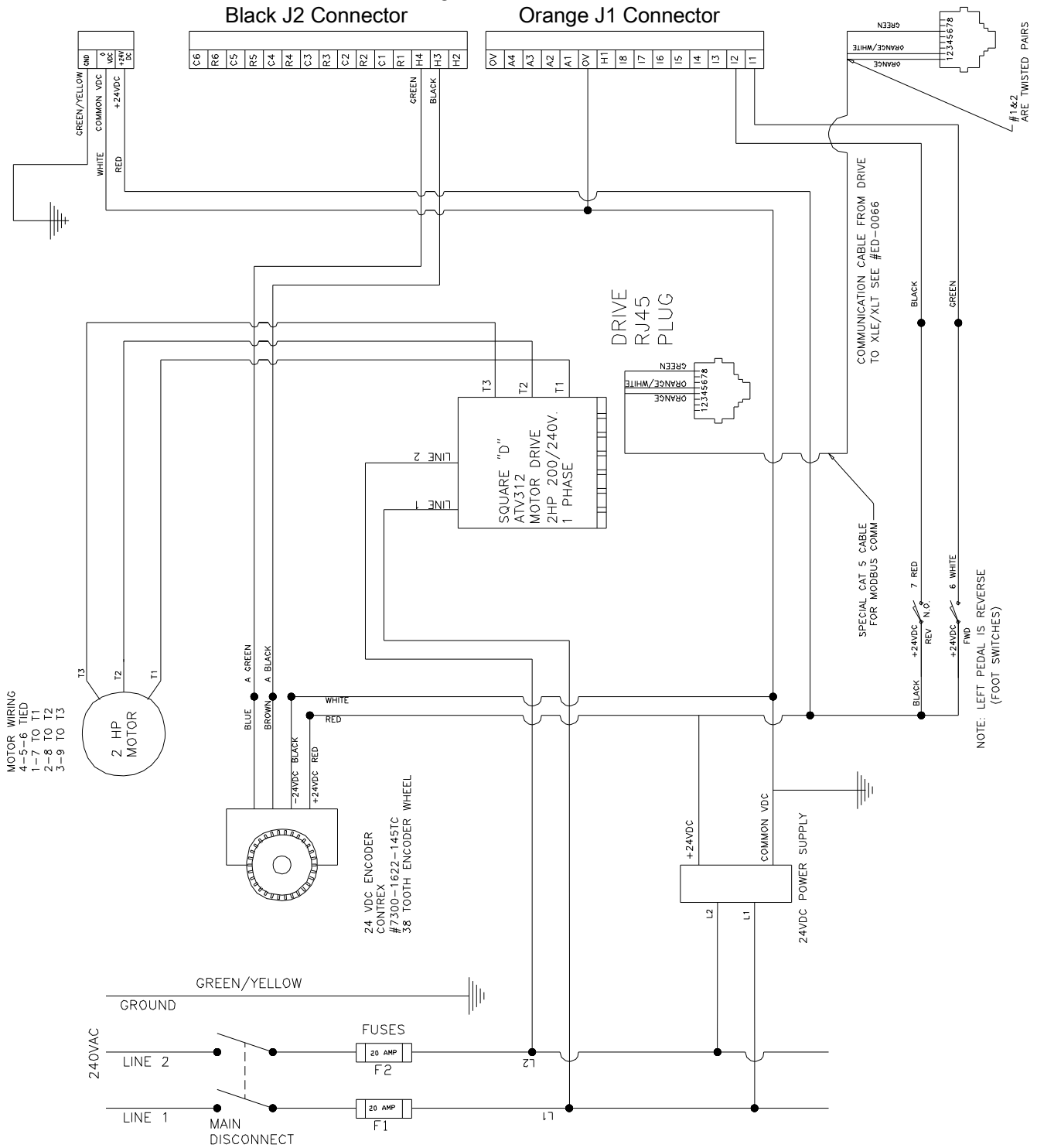



Electrical Components

⚠ WARNING: Make sure the electrical disconnect is OFF before working on the machine. Use the lockout provided on the main disconnect switch. Wait at least 1 min before working on any circuit, because the VFD capacitors may have energy stored. Maintenance should be performed on a regular basis by qualified personnel. Always follow proper safety precautions when working on or around any machinery.

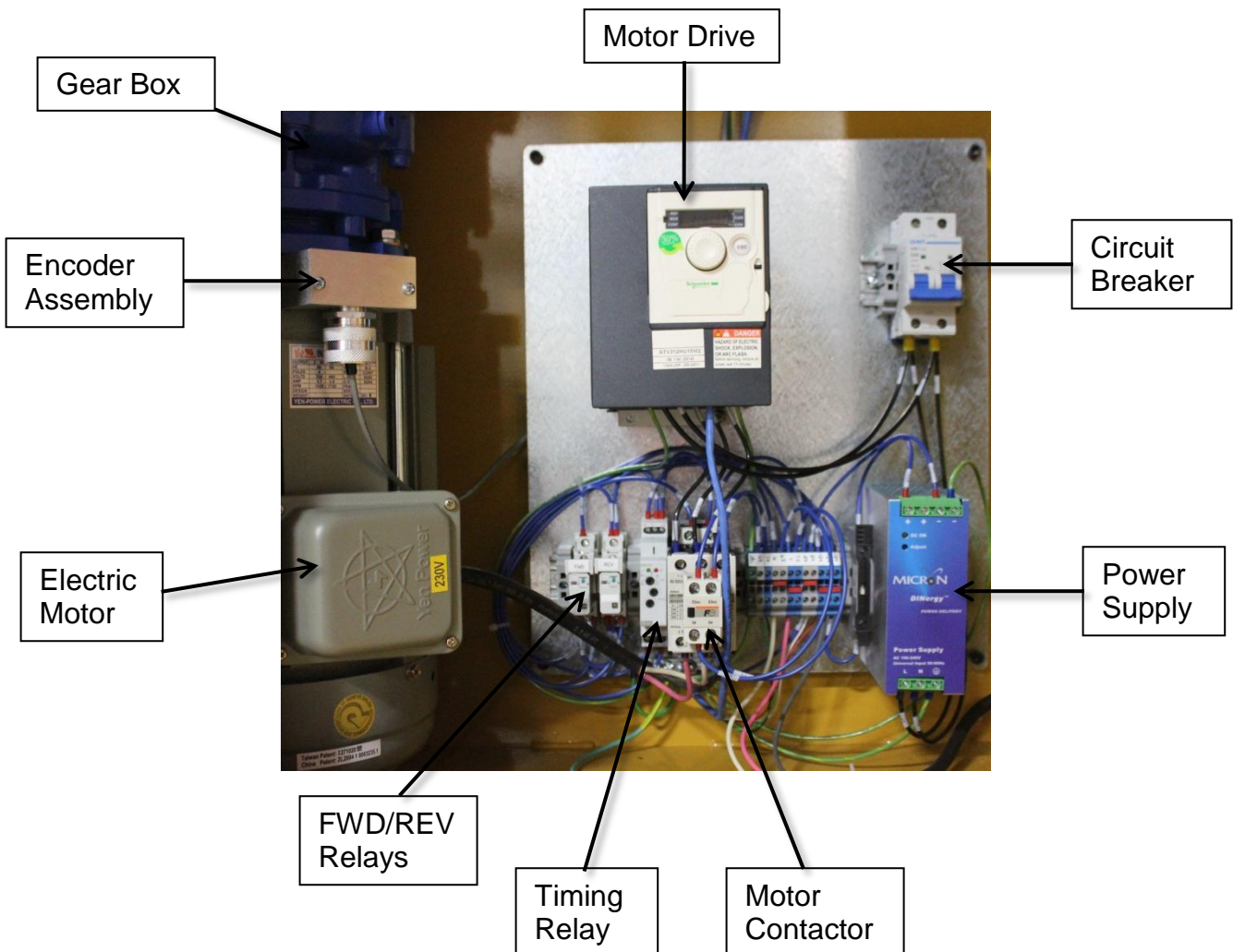



TROUBLESHOOTING

FAULT	PROBABLE CAUSE	REMEDY
Machine does not power up	Wrong or non-existent input power source. Blown fuse or tripped circuit breaker.	Check input power and verify voltage Check and replace fuses. Reset circuit breakers
Oil leaking from breather	Normal expansion of gearbox oil	Let oil purge from gearbox and take no further action.
Home position is not in correct position.	Loss of power during bending, or service work was performed	Go to homing screen on controller and repeat homing sequence. If not accessible, contact factory.
Material slips in hook arm	Too much oil on tubing or oil is on the die groove. Clear Radius is too tight. Material has too thin of wall thickness.	Clean material and die groove with solvent. Increase clear radius. Increase wall thickness. Material may need to be clamped top hook arm to prevent slipping. Only the counter die should be lubed
Poor bend results	Worn counter die. Worn die groove. Wrong size material and or wall thickness. Too tight of a clr.	Replace counter die. Replace die. Verify material size is correct. Verify clr
Twisting material	Bend die is not bolted down, Misaligned counter die, worn spindle bearing	Verify the bend die is bolted down to the spindle. Check counter die alignment. Replace spindle bearing
Machine overloads and wont bend	Material is too big for machines capacity. Tensile strength of material is too high. Input power is too low. Bending speed is too fast. No lube on counter die.	Verify material wall thickness and diameter for capabilities. Get material with lower tensile strength. Lower bend speed. Verify input power.
Inaccurate bending	Counter Die leadscrew position is changing. Material diameter is not consistent	Verify that the counter die leadscrew is holding its position via the counter. Check material diameter with a caliper to verify size.



ARC LENGTH TABLE

EXAMPLE: Arc Length = Constant x Bend Radius. Example: 90deg bend with 6" clr

EXAMPLE: 1.575 (from table) x 6" (clr) = 9.45" (Arc Length)

For bends more than 90deg, Constants can be added together.

Degrees	Constant	Degrees	Constant	Degrees	Constant
1	0.0175	31	0.5410	61	1.0645
2	0.0349	32	0.5584	62	1.0819
3	0.0524	33	0.5759	63	1.0994
4	0.0698	34	0.5933	64	1.1168
5	0.0873	35	0.6108	65	1.1343
6	0.1047	36	0.6282	66	1.1517
7	0.1222	37	0.6457	67	1.1692
8	0.1396	38	0.6631	68	1.1866
9	0.1571	39	0.6806	69	1.2041
10	0.1745	40	0.6980	70	1.2215
11	0.1920	41	0.7155	71	1.2390
12	0.2094	42	0.7329	72	1.2564
13	0.2269	43	0.7504	73	1.2739
14	0.2443	44	0.7678	74	1.2913
15	0.2618	45	0.7853	75	1.3088
16	0.2792	46	0.8027	76	1.3262
17	0.2967	47	0.8202	77	1.3437
18	0.3141	48	0.8376	78	1.3611
19	0.3316	49	0.8551	79	1.3786
20	0.3490	50	0.8725	80	1.3960
21	0.3665	51	0.8900	81	1.4135
22	0.3839	52	0.9074	82	1.4309
23	0.4014	53	0.9249	83	1.4484
24	0.4188	54	0.9423	84	1.4658
25	0.4363	55	0.9598	85	1.4833
26	0.4537	56	0.9772	86	1.5007
27	0.4712	57	0.9947	87	1.5182
28	0.4886	58	1.0121	88	1.5356
29	0.5061	59	1.0296	89	1.5531
30	0.5235	60	1.0470	90	1.5705



PARTS DIAGRAM

Base Assembly Parts Diagram

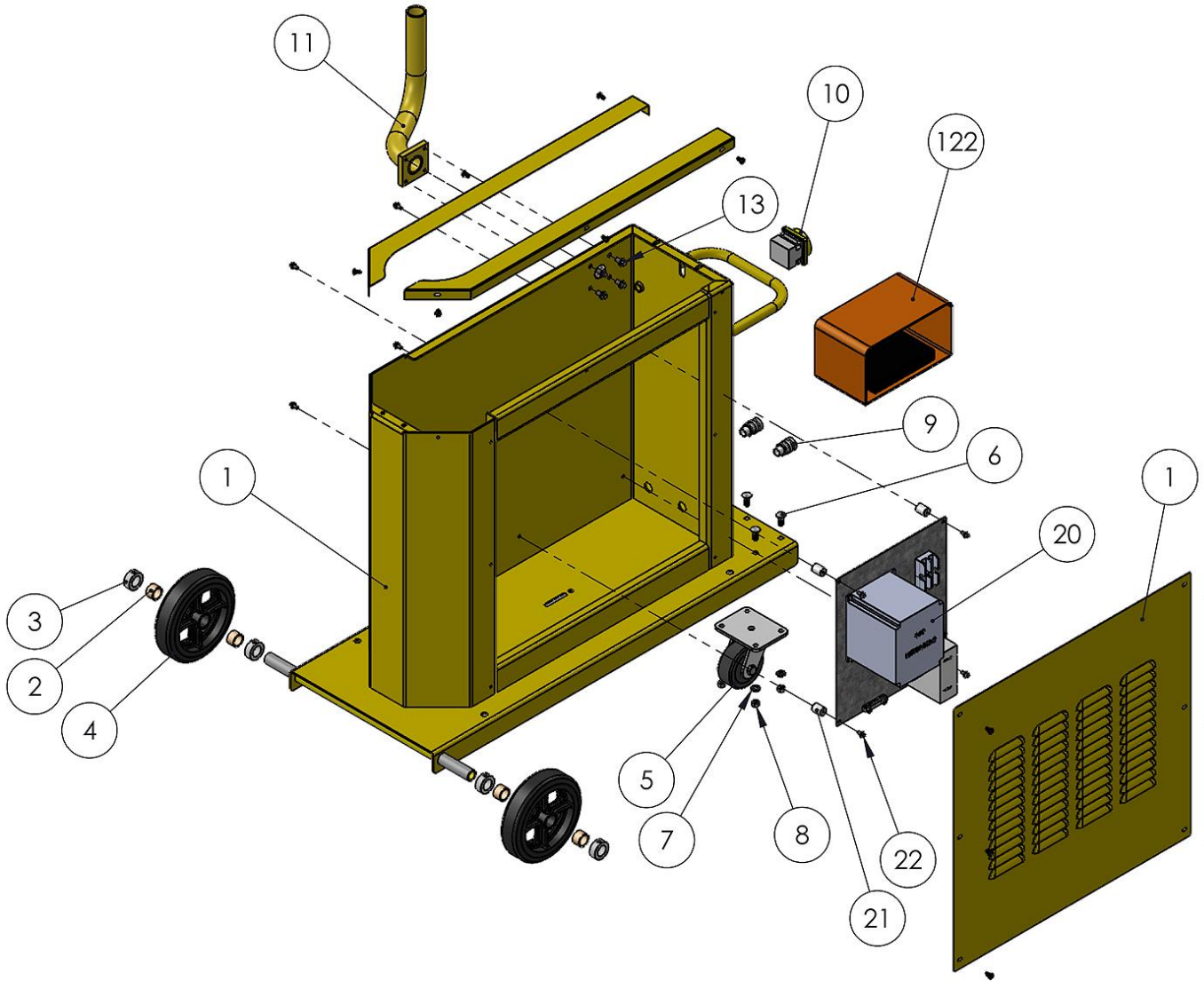



Gear Box Parts Diagram

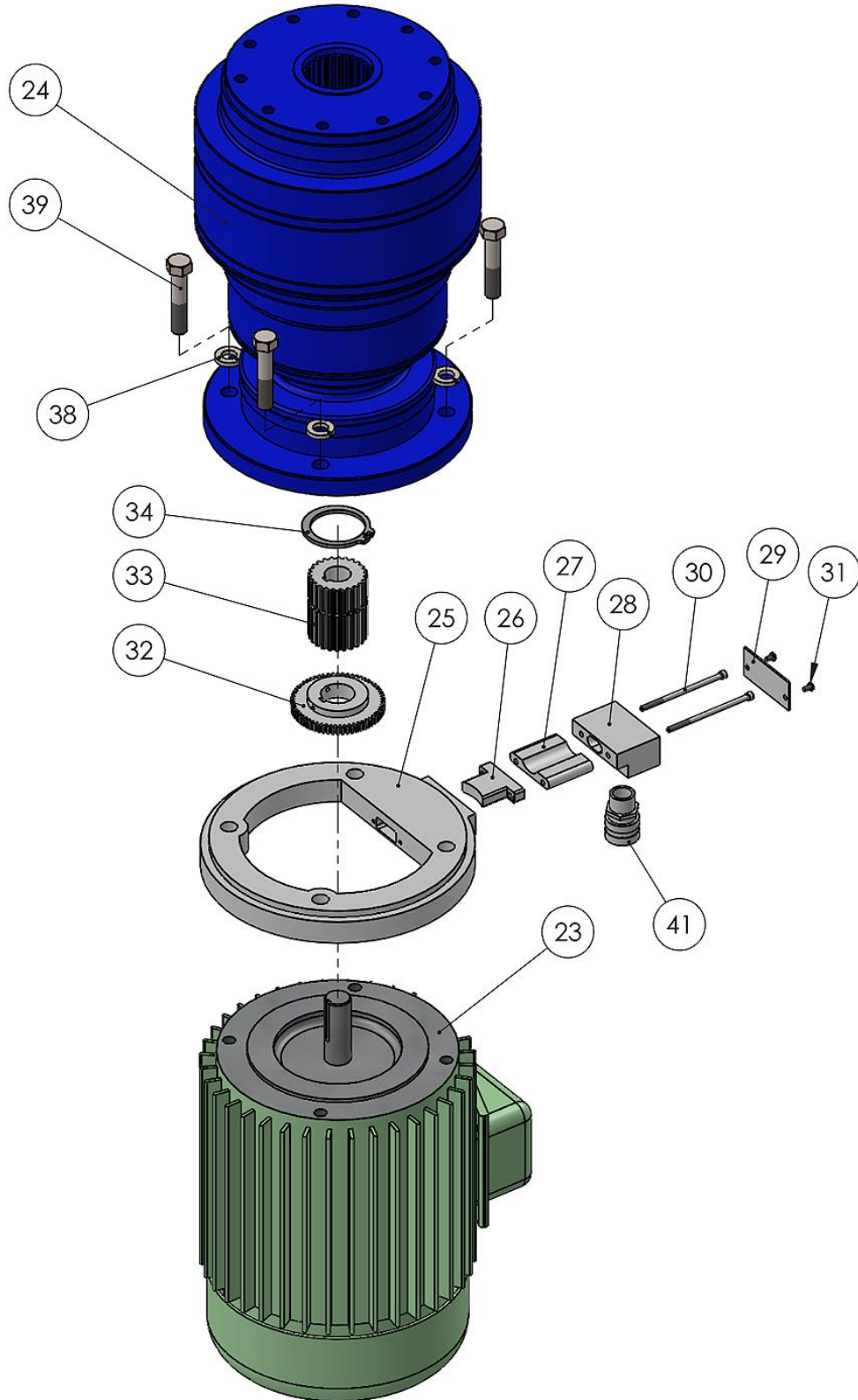



Top and Bottom Plate Assembly Parts Diagram

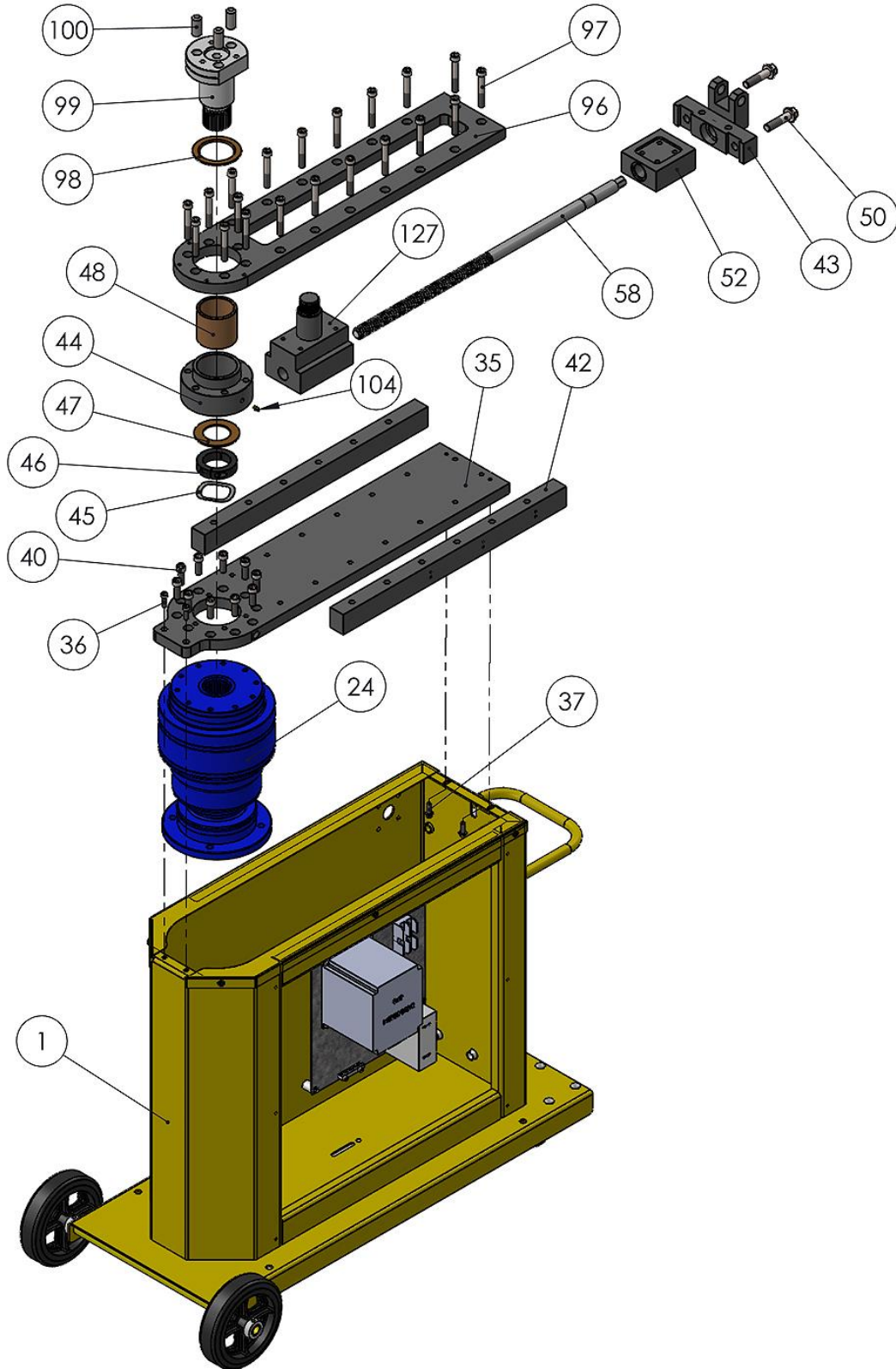



Lead Screw Assembly Parts Diagram

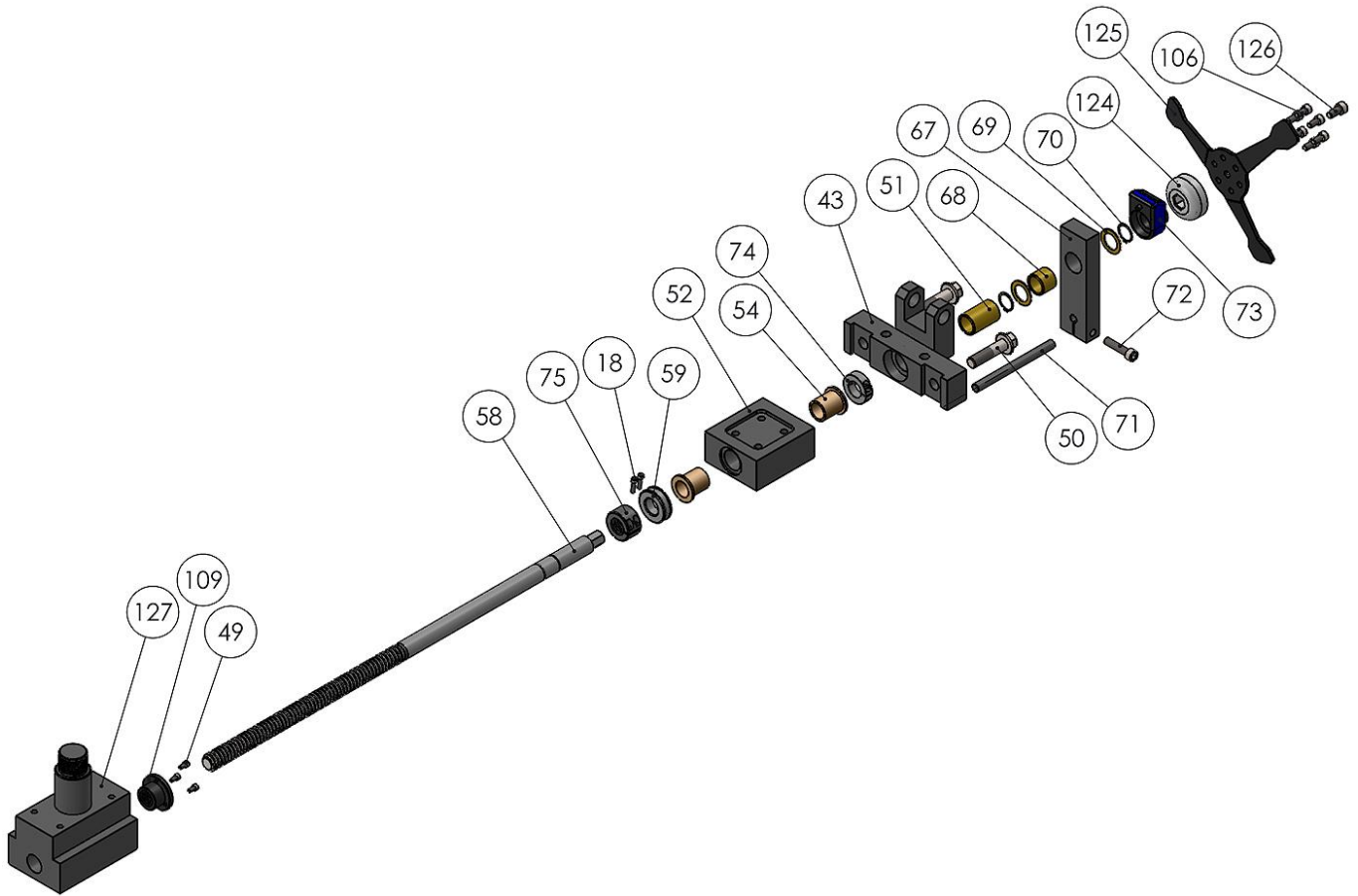



Actuator Assembly Parts Diagram

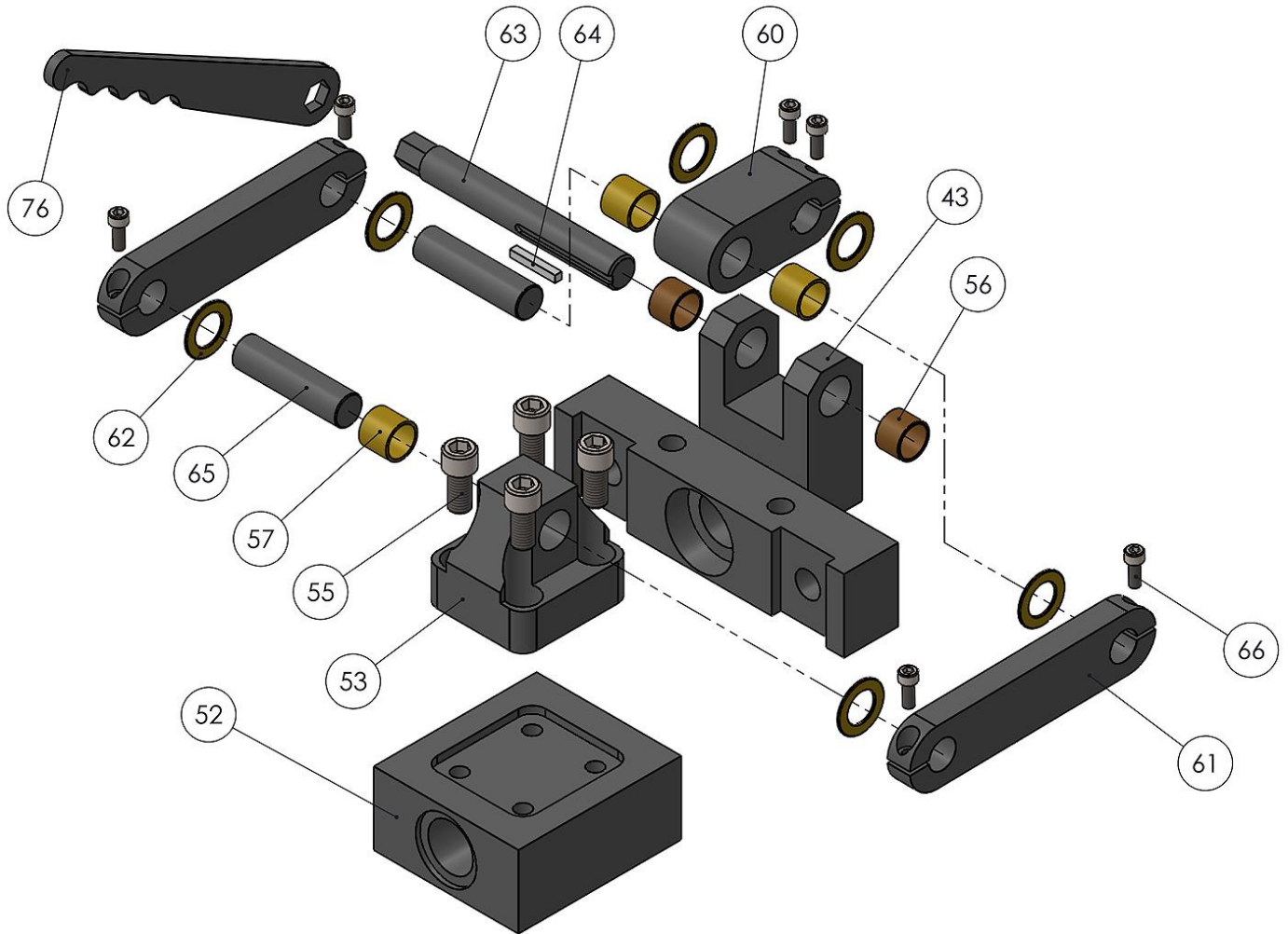



Spiral Bend Plate Counter Die Assembly Parts Diagram

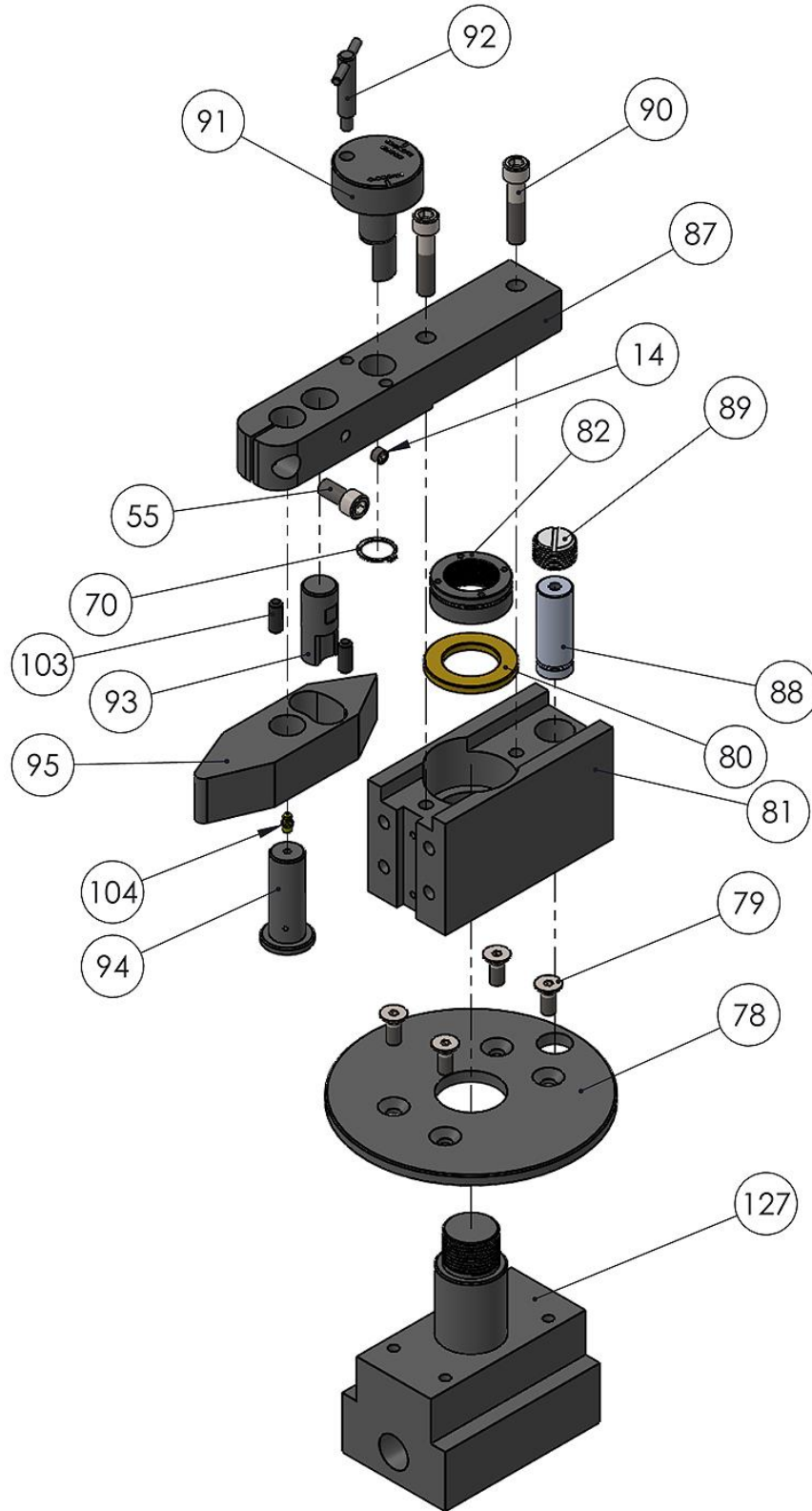



Pivot Pin Assembly Parts Diagram

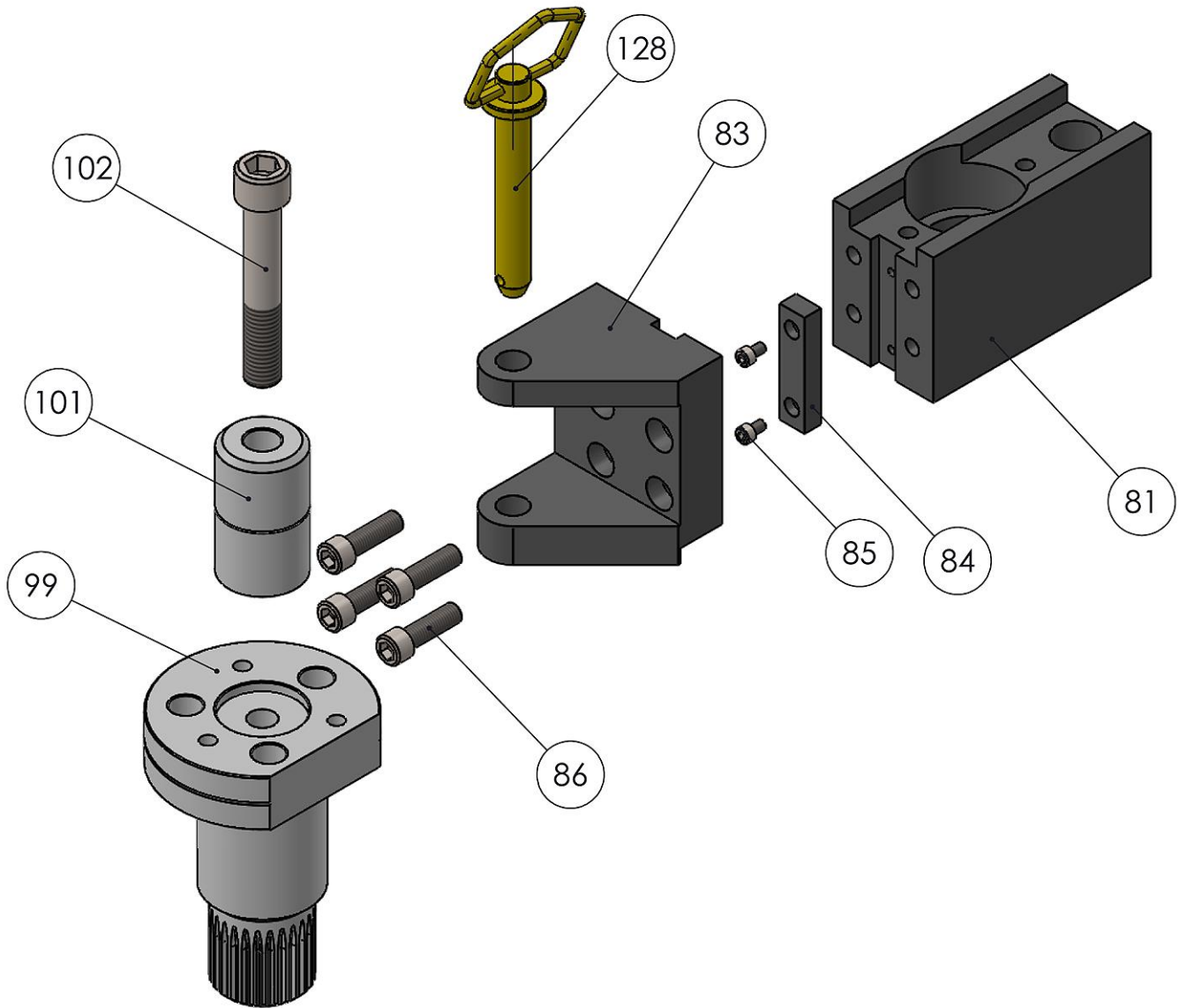



Roller Counter Die Assembly Parts Diagram

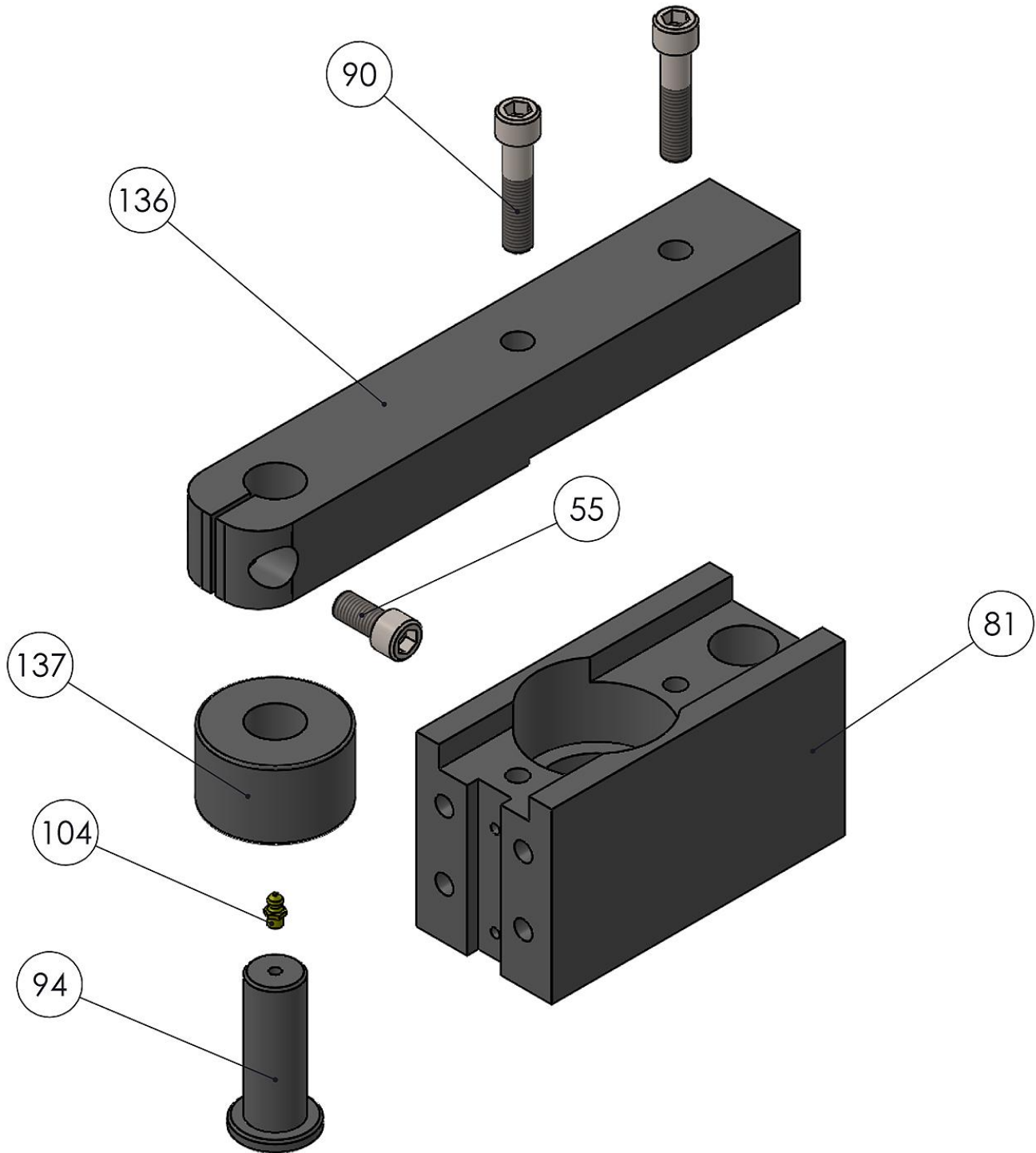



Spiral Bend Plate Assembly Parts Diagram

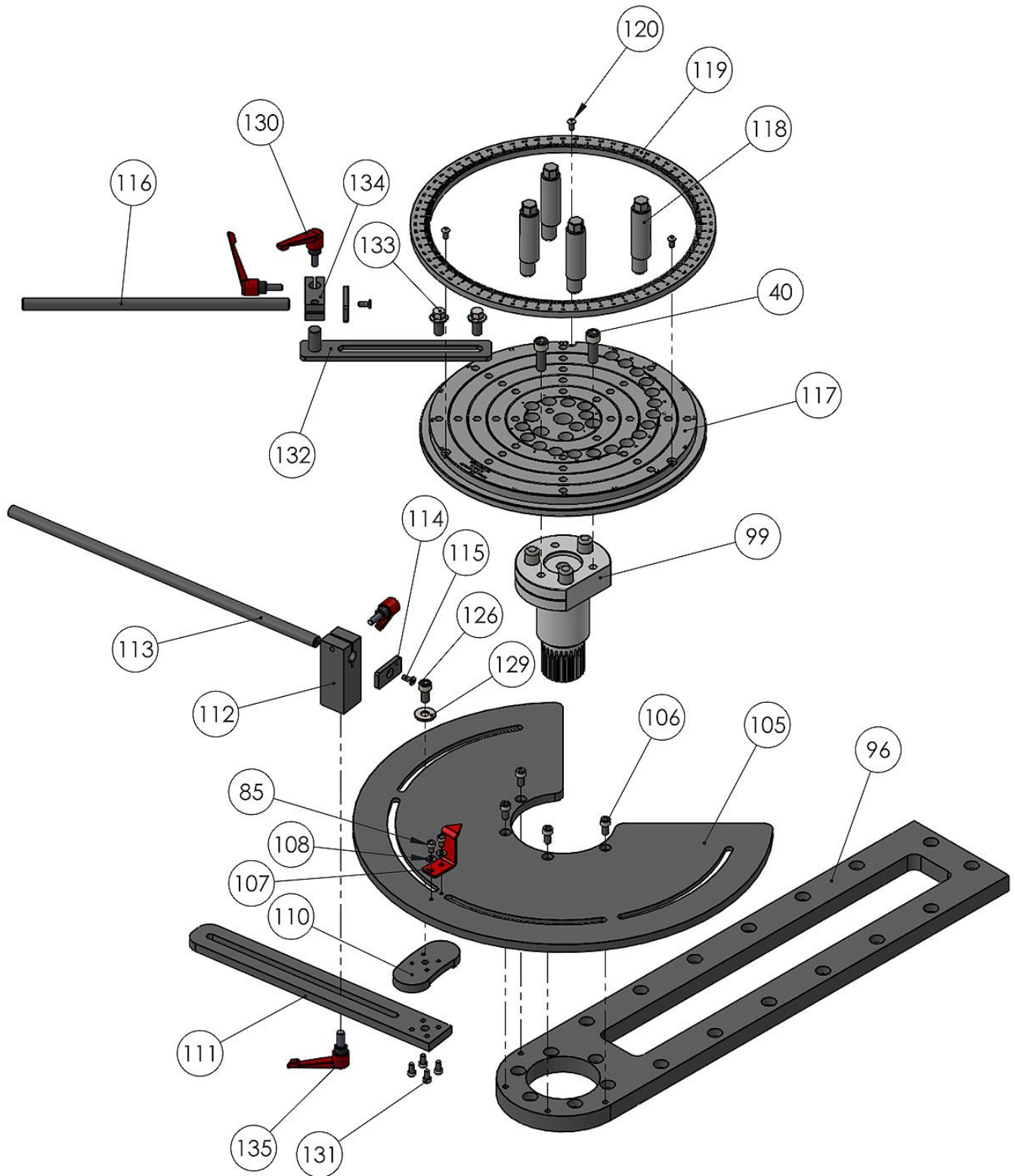



Control Box Assembly Parts Diagram

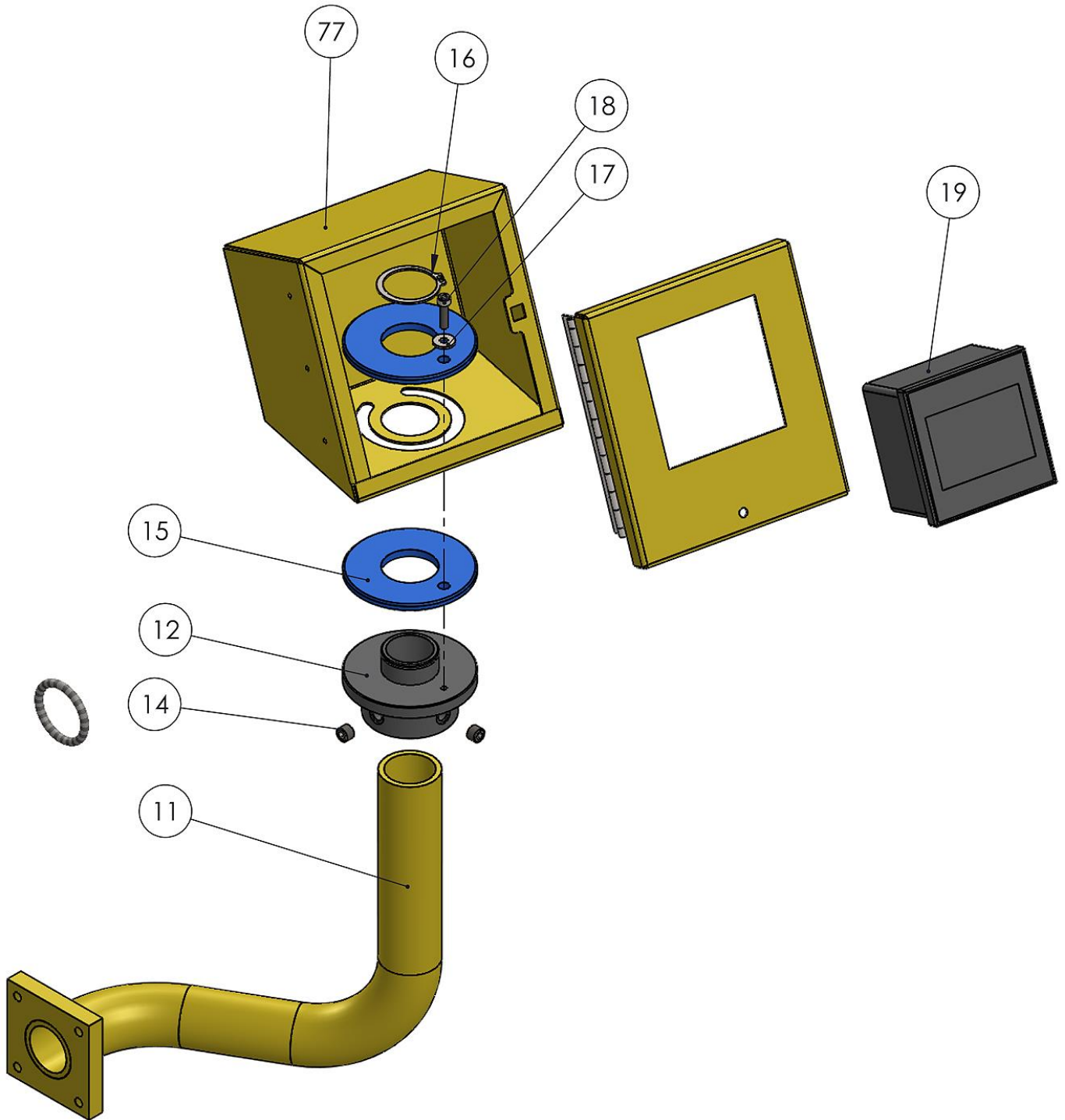



Tool Box Assembly Parts Diagram

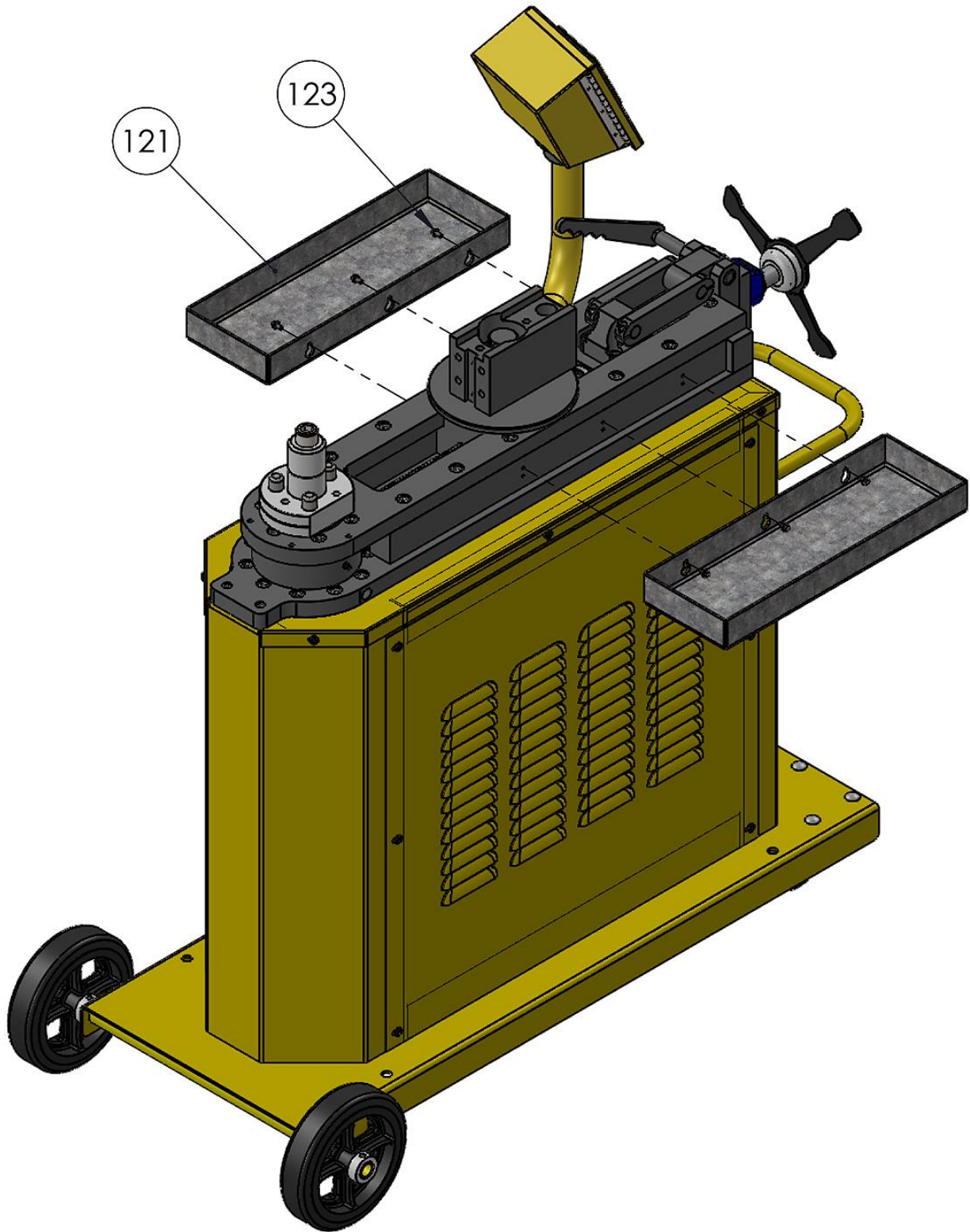



Parts List

Item	Part Number	Description	Qty.
1	M275-5A020	M275 Cart	1
2	PP-0043	1.0 ID x 1.1875 OD x 0.75 LG Bushing	4
3	PP-0035	1" Set Screw Collar	4
4	PP-0064	8" Rubber Wheel	2
5	PP-0048	4.0 Inch Caster	2
6	STD.	3/8-16 x 1 Carriage Bolt	8
7	3/8 LOCK WASHER	Std.	8
8	STD.	3/8"-16 Hex Nut	8
9	PP-0025	Cord Grip	2
10	PP-0304	On/Off 2 Pole Switch	1
11	ME-M250-5A009	Control Box Arm	1
12	ME-M350-7A057	Electrical Box Pivot Hub	1
13	M8 X 1.25 X 14	Hex Flange	4
14	M10 X 1.5 X 8	Set Screw	3
15	M350-7A058	Electrical Box Washer	2
16	1.50 EXT. RETAINING RING	Std.	1
17	M5 FLATWASHER	Std.	1
18	M5 X 0.8 X 20	SHCS	3
19	PP-1188	XLT Controller	1
20	M250-6A016	M250 Electrical Panel	1
21	ME-M200-7A005	Stand Off	4
22	M6 X 1.0 X 12	Hex Flange	8
23	PP-1081	3hp 3phase Motor	1
24	PP-1242	Gear Box	1
25	PP-0453-C	Encoder Adaptor	1
26	PP-0453-G	Encoder	1
27	PP-0453-D	Spacer	1
28	PP-0453-B	Encoder Housing	1
29	PP-0453-A	Housing Cover	1
30	8-32 X 3.25	SHCS	2
31	6-32 X .25	Cross Machine Screw	2
32	PP-0453-F	Encoder Gear	1
33	PP-0454-B	Spline Adaptor	1



Item	Part Number	Description	Qty.
34	STD.	Ext. Retaining Ring	1
35	M275-6A001	Bottom Plate M275	1
36	M8 X 1.25 X 25	SHCD	2
37	M8 X 1.25 X 25	Hex Flange	2
38	1/2 LOCK WASHER	Std.	4
39	1/2-13 X 2.50	HHCS	4
40	M12 X 1.75 X 35	SHCS	12
41	PP-0023	Cord Grip	1
42	M275-6A003	Side Frame	2
43	M275-6A017	End Block	1
44	M250-7A002	Bearing Hub	1
45	PP-0819	Wave Spring	1
46	PP-0731	2.25" Clamp Collar	1
47	M300-7A032	Thrust Washer	1
48	PP-0780	2.75 ID x 3.25 OD x 3.0 LG Bushing	1
49	M5 X 0.8 X 10	SHCS	3
50	M16 X 2.0 X 65	Hex Flange	2
51	PP-0142	1.25 OD x 1.00 ID x 2.00 LNG	1
52	M275-6A006	Actuator Block	1
53	M275-6A018	Push Block	1
54	PP-0054	1.0 ID x 1.25 OD x 1.5LG	2
55	M12 X 1.75 X 25	SHCS	6
56	PP-1064	.75 I.D. X .875 O.D. X .625 Bushing	2
57	PP-0053	0.75 Id X 0.875 Od X 0.75 Wide	4
58	M275-5A007	Lead Screw Weldment	1
59	1.0 THRUST BEARING	Thrust Bearing (McMaster #60715k15)	1
60	M275-6A019	Toggle Block	1
61	M275-6A020	Toggle Link	2
62	PP-0101	0.75 ID x 1.25 OD x .0625 THK	6
63	M275-7A012	Actuator Shaft	1
64	STD.	.1875 x 1.25 Key Stock	1
65	M275-7A021	Pivot Pin	2
66	M6 X 1.0 X 14	SHCS	6
67	ME-M400-6A012-V2	Counter Mount	1
68	PP-0144	1.0 ID x 1.25 OD x 1.0 Long	1



Item	Part Number	Description	Qty.
69	PP-0935	1.0 ID x 1.5 OD x .0625 THK	2
70	STD	1" Ext. Retaining Ring	3
71	M275-7A022	Guide Shaft	1
72	M10 X 1.5 X 45	SHCS	1
73	PP-0137-V2	FIAMA Counter	1
74	PP-0036	1.0 Clamp Collar (Split)	1
75	M275-7A023	Lead Screw Stop Nut	1
76	M275-6A045	Release Handle	1
77	M250-5A008	Electrical Box For XLT	1
78	M275-6A036	Latch Plate	1
79	M10 X 1.5 X 25	FHCS	4
80	M275-7A017	Locknut	1
81	M275-6A037	Pivot Block	1
82	LOCK RING		1
83	M275-6A026	Counter Die Mount	1
84	M275-6A031	Vertical Key	1
85	SHCS	M6 X 1.0 X 10	4
86	M12 X 1.75 X 40	SHCS	4
87	M275-6A038	Pivot Nose Arm	1
88	M275-7A019	Shear Pin	1
89	M275-7A018	Spring Plug	1
90	M12 X 1.75 X 55	SHCS	2
91	M275-7A006	Selector Hub	1
92	PP-1530	Release Plunger	1
93	M275-7A007	Spring Stop	1
94	M275-7A009	Retaining Pin	2
95	M275-6A025	Bending Nose	1
96	M275-6A002	Top Plate M275	1
97	M12 X 1.75 X 80	SHCS	20
98	M300-7A031	Thrust Washer	1
99	ME-M250-7A008	M250 Spindle (Metric)	1
100	PP-1071	3/4" Dowel Pin	3
101	ME-M300-7A003	Center Pin	1
102	M20 X 2.5 X 120	SHCS	1
103	PP-1178	Polyurethane	2



Item	Part Number	Description	Qty.
104	.25-28 GREASE ZERK	Straight Grease Zerk	3
105	M275-6A024	Arc Plate	1
106	M8 X 1.25 X 16	SHCS	10
107	M275-6A034	Pointer	1
108	M6 FLAT WASHER	Std.	2
109	ME-M250-7A010	Lead Screw Nut Insert	1
110	M275-6A028	Arc Slide	1
111	M275-6A027	Stop Bar	1
112	M275-6A029	Stop Block	1
113	M275-7A011	Stop Shaft	1
114	M275-6A035	Stop Plate	2
115	M6 X 1.0 X 16	FHCS	2
116	M275-7A025	Stop Arm Shaft	1
117	M275-6A032-V2	Spiral Bend Plate	1
118	M275-7A008	Lock Pin	4
119	M275-6A033	Degree Ring	1
120	M6 X 1.0 X 12	Button Head	3
121	M275-6A044	Tool Tray	2
122	PP-0666	Foot Pedal	1
123	M5 X 0.8 X 10	HHCS	6
124	ME-M300-7A034	Handwheel Mounting Hub	1
125	M300-6A066	Hand Wheel	1
126	M10 X 1.5 X 20	SHCS	2
127	M275-5A008	Pivot Pin Assembly	1
128	PP-0476	Hitch Pin Assembly (Short)	1
129	M10	Flatwasher	1
130	PP-1527	M8 Handle	3
131	M6 X 1.0 X 12	SHCS	4
132	M275-5A009	Stop Arm Assembly	1
133	M12 X 1.75 X 25	Hex Flange	2
134	M275-6A043	Clamp Block	1
135	PP-1528	M10 Handle	1
136	M275-6A041	Roller Arm	1
137	M275-7A020	Counter Die Roller	1



NOTES



NOTES



BAILEIGH INDUSTRIAL, INC. 1625 DUFEEK DRIVE MANITOWOC, WI 54220

PHONE: 920. 684. 4990 FAX: 920. 684. 3944

www.baileigh.com

BAILEIGH INDUSTRIAL, INC. 1455 S. CAMPUS AVENUE ONTARIO, CA 91761

PHONE: 920. 684. 4990 FAX: 920. 684. 3944

BAILEIGH INDUSTRIAL LTD. UNIT 1 FULLWOOD CLOSE

ALDERMANS GREEN INDUSTRIAL ESTATE

COVENTRY, CV2 2SS UNITED KINGDOM

PHONE: +44 (0)24 7661 9267 FAX: +44 (0)24 7661 9276

WWW.BAILEIGHINDUSTRIAL.CO.UK

BAILEIGH INDUSTRIAL GMBH HOFENER STRAÙE 64

70736 FELLBACH

DEUTCHSLAND

WWW.BAILEIGHINDUSTRIAL.DE

BAILEIGH INDUSTRIAL PTY. LTD.

P.O Box 1573, 126 MELROSE DRIVE TULLAMARINE,

VIC 3043 AUSTRALIA

WWW.BAILEIGHINDUSTRIAL.COM.AU