

NATIONAL

SHEET METAL MACHINES, INC.

SAFETY & INSTRUCTIONS

MANUAL

U4816

BRAKE MACHINE

MADE IN USA



Trick-Tools.com

80 Truman Road

Pella, IA 50219

Phone: 1-877-VAN-SANT

E-mail: sales@trick-tools.com



CONTENTS

For Safe and Efficient Operation	1
Safe Zone.....	2
Parts Lists.	3-4
Machine Dimensions	5
Floor Bolt Patterns	5
Anchor Points	5
Set-Up Procedures.....	6
Adjusting Procedure	7
Beam Adjustment.	7
Adjusting Nose bar for Straightness.....	7
After Nose Bar is Straight.....	8
Rated Bending Capacity	9
Preventative Maintenance.....	10
Recommended Lubricant.....	10
Troubleshooting Guide.....	10
Warranty.....	11

RECORD MACHINE INFORMATION HERE
(Necessary for Factory Service, Replacement Parts, etc.)

Model Number :

Serial Number :

Date Installed :

Purchased Through :

NATIONAL

SHEET METAL MACHINES, INC.

SAFETY

NEVER place any part of your body under the Blade Area...

NEVER stack material to be bent. Design is for one (1) piece at a time...

NEVER place material in the brake that is over capacity or not designed to bend...

Check for broken or damaged parts before using you brake.. Repair or replace damaged parts....

ALWAYS keep children, pets, and visitors at a SAFE distance from this machine
When operating...

Keep floors dry and free of clutter and slippery materials, maintain good footing and blance, and do **NOT "OVERREACH"**...

ALWAYS check the Zone Working Area (see Safe Zone Diagram pg. 3) before you start your bend. Be sure the area is clear of ALL people.

Use Common sense when using this brake. **THINK SAFETY** at ALL times.
DO NOT use the brake if you are fatigued...

ALWAYS use replacement parts that are manufactured for this brake...

ALWAYS check your Counterweight Rods and Counterweights to make sure they are SECURE BEFORE you use the brake...

Floor brakes should be bolted to the floor, bench brakes should be bolted to stand, then stand and brake should be bolted to floor to prevent brake from tipping over when bending force is applied....

Follow Preventative Maintenance Guide Daily...

Anyone who operates this brake should read the **COMPLETE** brake manual BEFORE they use the brake.....

NEVER bend rods, wires, multiple thicknesses, or across lock seams. Operations Of this type will result in denting the edge of the Apron and Beam and springing the machine out of line.

SAFETY SAVES AND SAFETY PAYS

SAFE ZONE (Working Area)

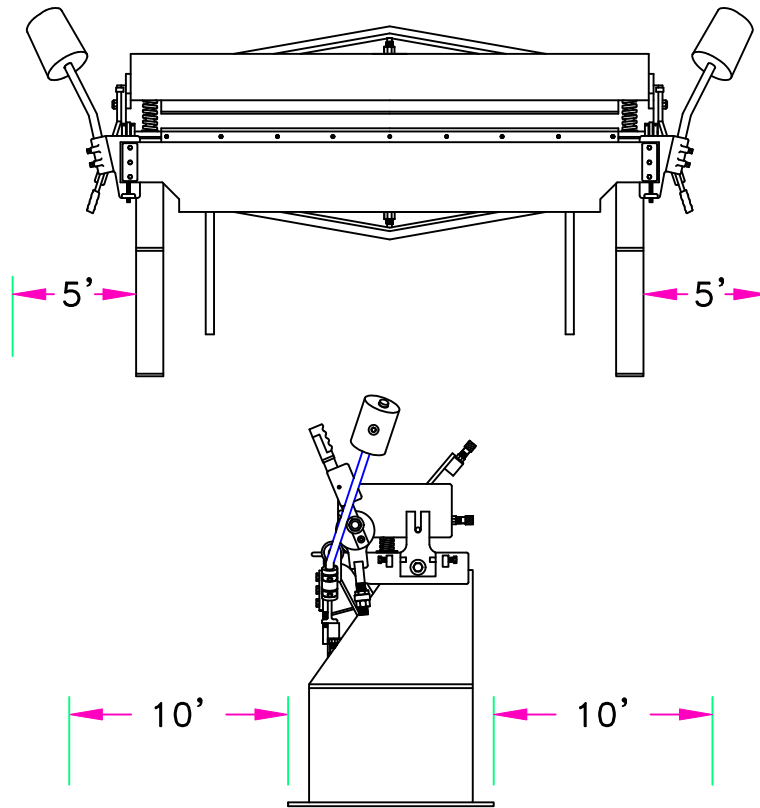

1. Allow a minimum five (5) feet of open area, free of materials, and machinery on BOTH sides (Left & Right) of machine.
2. Allow a minimum ten (10) feet of open area, free of obstruction, etc. in REAR of machine.
3. Allow a minimum ten (10) feet of open area, free of obstruction, etc. except OPERATOR in FRONT of machine.
4. Do NOT operate machine when People or Obstructions are within SAFE ZONE. Serious injury may occur.
5. Do NOT stack, store or place material, machinery, or any other obstructions in FRONT of machine that might cause tipping or in any way present a HAZARD to operators and/or helpers.

KEEP WORK AREA AND SAFE ZONES CLEAN

NATIONAL

PARTS LIST U3616 & U4816 HEAVY DUTY BENCH BRAKE

PART#	DESCRIPTION	QTY.	PART#	DESCRIPTION	QTY.
101.	NOT APPLICABLE FOR THIS MACHINE	—	126.	NOT APPLICABLE FOR THIS MACHINE	—
102.	HEAD ADJ. SLIDE PLATE	2	126A.	NOT APPLICABLE FOR THIS MACHINE	—
103.	BOLT	4	127.	NOT APPLICABLE FOR THIS MACHINE	—
104.	BOLT	1	128.	NOT APPLICABLE FOR THIS MACHINE	—
105.	BUSHING	2	129.	DELETED	—
106.	NOT APPLICABLE FOR THIS MACHINE	—	130.	NOT APPLICABLE FOR THIS MACHINE	—
107.	NUT	2	131.	DELETED	—
108.	NUT	2	132.	ROD—REPEAT/STOP	1
109.	NUT	2	133.	COLLAR—REPEAT/STOP	1
110.	NOT APPLICABLE FOR THIS MACHINE	—	134.	SET SCREW	1
111.	NOT APPLICABLE FOR THIS MACHINE	—	135.	COTTER PIN	1
112.	CAM HANDLE	1	136.	SET SCREW	2
113.	APRON HINGE PIN	2	137.	NOT APPLICABLE FOR THIS MACHINE	—
114.	NOT APPLICABLE FOR THIS MACHINE	—	138.	CAM	2
114A.	NOT APPLICABLE FOR THIS MACHINE	—	139.	NOT APPLICABLE FOR THIS MACHINE	—
115.	BENDING ANGLE	1	140.	NOT APPLICABLE FOR THIS MACHINE	—
116.	FLAT WASHER	2	141.	RUBBER GRIP	2
117.	BOLT	5	142.	APRON HANDLE EXTENSION	2
118.	NOT APPLICABLE FOR THIS MACHINE	—	143.	SET SCREW	2
118A.	NOT APPLICABLE FOR THIS MACHINE	—			
119.	NOT APPLICABLE FOR THIS MACHINE	—			3' 4'
120.	NOT APPLICABLE FOR THIS MACHINE	—	C150.	FINGER SCREW	24 32
121.	NOT APPLICABLE FOR THIS MACHINE	—	C153.	2" FINGER	3 4
122.	NOT APPLICABLE FOR THIS MACHINE	—	C154.	3" FINGER	4 6
123.	TOGGLE PIN	2	C155.	4" FINGER	4 5
124.	WASHER	2	C156.	2" SLOTTED FINGER	1 1
125.	RING ASSEMBLY	2			

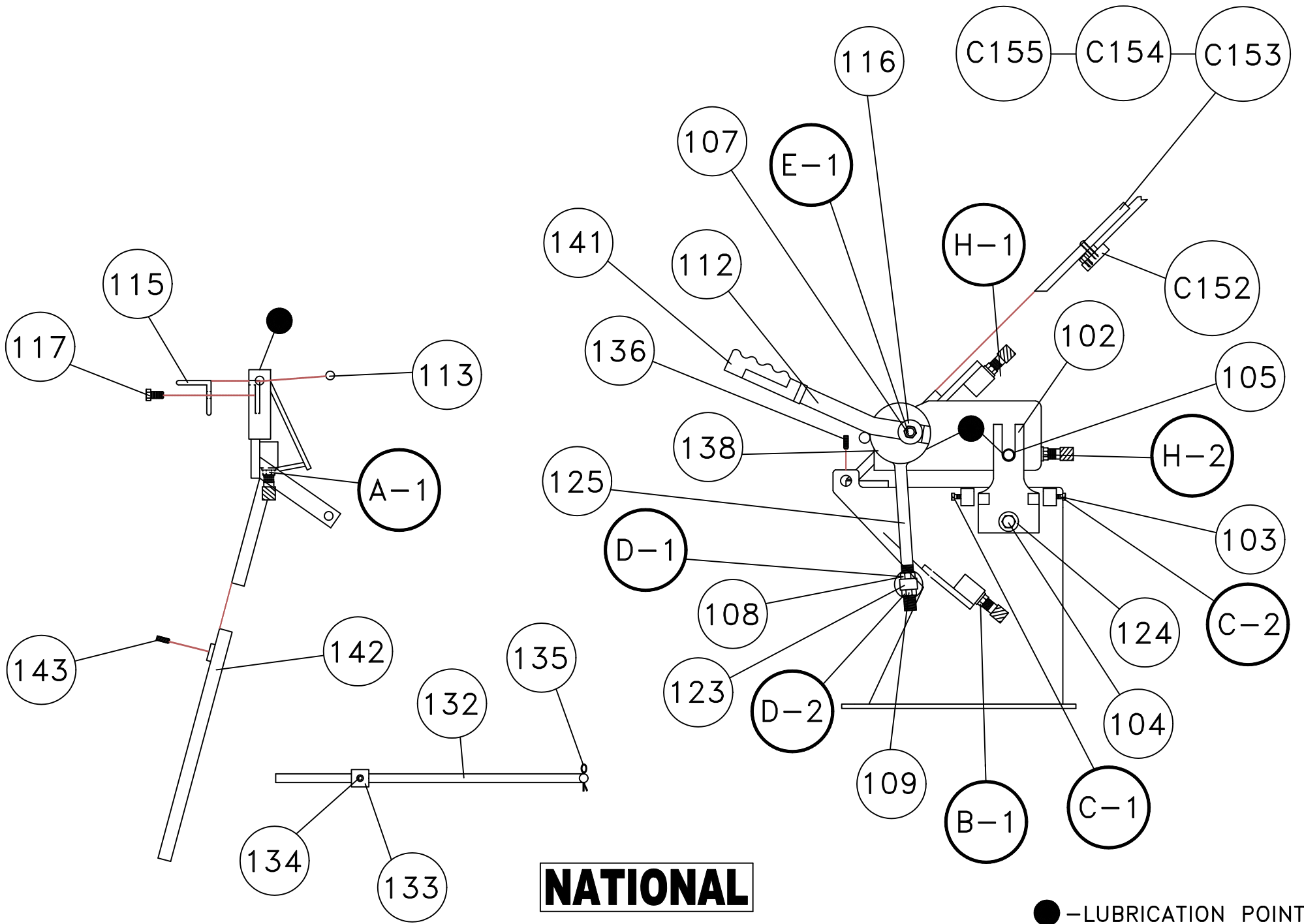

NATIONAL

PARTS LIST U3616 & U4816
HEAVY DUTY BENCH BRAKE

● - LUBRICATION POINT
▨ - PRESSURE BAR

4.

MACHINE DIMENSIONS

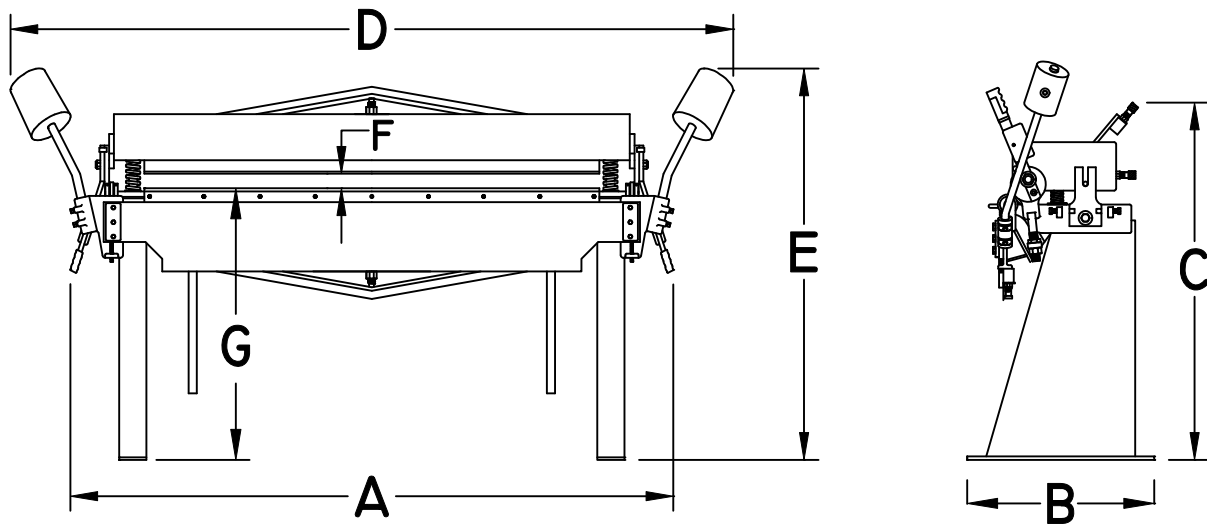

MODEL	A LENGTH	B WIDTH	C HEIGHT	D LENGTH W/C WEIGHTS	E HEIGHT W/C WEIGHTS	SHIPPING WEIGHT	F APP. MAX. CLEARANCE BETWEEN APRON EDGE & NOSE BEAM
S3616	51 1/2"	20 1/4"	24 1/2"	-	-	370 lbs.	1 1/2"
S4816	63 1/2"	20 1/4"	24 1/2"	-	-	470 lbs.	1 1/2"
U3616	51 1/2"	20 1/2"	24 1/2"	-	-	400 lbs.	1 3/4"
U4816	63 1/2"	20 1/2"	24 1/2"	-	-	500 lbs.	1 3/4"
STAND	54"	19"	27 1/4"	-	-	100 lbs.	-

FLOOR BOLT PATTERN ANCHOR POINTS

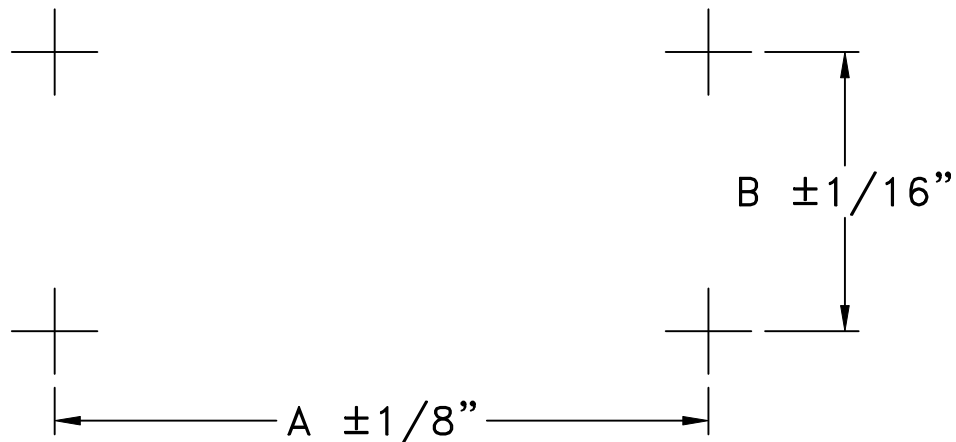

MODEL	A	B
STAND	52 1/4"	17 1/2"

BENCH BRAKES REQUIRE STAND

SET UP PROCEDURES

1. Prepare locations for machine. (See Safe Zone Diagram pg. 2, Anchor Points pg. 15, and Machine Dimensions Chart pg. 13 for proper positioning)
2. Install Anchors into floor at desired location.
3. Remove and properly dispose of all cardboard and metal wrap, inspect machine for damages.
4. Carefully position machine over anchors.
5. Level the Brake and / or Stand and shim under the feet, if necessary, to avoid distortion.
6. Bolt Floor Brake feet **FIRMLY** to Floor to **PREVENT TIPPING**, or for Bench Brakes; bolt Brake feet **FIRMLY** to Stand and then bolt Stand and Brake to floor. Bolt the front feet of Stand **FIRMLY** to floor to **PREVENT TIPPING** when bending force is applied to the Apron Handles.
7. Make sure Nose Bar is STRAIGHT two ways: **Front Edge and Flat Underneath.**

***** If using straight edge, inspect to make sure it has maintained its Accuracy. Straightness of Nose Bar can also be checked by using a heavy gauge fishing line stretched tightly from LEFT side of machine, UNDER the Nose Bar, to RIGHT side of machine. *****

ADJUSTING PROCEDURES

TO ADJUST NOSE BAR FOR STRAIGHTNESS IF REQUIRED

1. Loosen Pressure Bar (H-2)
2. Tighten (H-1) until Nose Bar is STRAIGHT
3. Then tighten (H-2) back

>> **MAKE SURE NOSE BAR IS STRAIGHT BEFORE GOING ANY FURTHER**<<

The Nose Bar being the strongest member of the Brake, the material
Clamped to be bent will take same shape as Nose Bar.

BEAM ADJUSTMENTS FOR MILD STEEL

Machine Gauge	Clearance
18	7 / 64"
16	1 / 8"
14	5 / 32
12	7 / 32"

The Upper Beam adjusts to a maximum 5/8" from Rear on Bench Brakes

When adjusting to bend material same as machine gauge, swing the Apron up to **90 degrees** and set the Beam Adjustment to a designated clearance between the Apron Edge and Nose Beam tip. (See Beam Adjustment Chart Above.) For lighter material, a clearance of **2 times** material thickness should be used. **SOFT Aluminum** may be formed with clearance **EQUAL** to material thickness.

AFTER NOSE BAR STRAIGHT

1. Clamping pressure is controlled by Nuts (108) and (109) on the **LOWER END** of the Cam Bolt. This pressure should be adjusted with a small piece of the material to be bent clamped in **EACH** end of the machine. Move the Nuts (108) and (109) so that the Cam Handles (112) pull against the Stops with an **EQUAL** effort. Excessive clamping pressure is **NOT** required. Use only enough to Hold the material **FIRMLY** in the brake.
2. Use (D-1) and (D-2) to adjust clamping pressure on each end to hold material to be bent. **Excessive Pressure is NOT REQUIRED.**
3. Use (B-1) to adjust Base to clamp material in **CENTER** enough to keep material from "crawling" when Bending.
4. **BENCH BRAKES:** Make sure Apron is **FLUSH with BASE on EACH END.** Use (A-1) to move center of Apron up **1/32" HIGHER** than Base.

FLOOR MODEL BRAKES: Make sure Apron is **FLUSH with BASE on Each End.** Use (A-1) to move Center of Apron up **1/32" HIGHER** than Base. If Apron is Away from Base in Center use (A-2) And (A-3) to make proper adjustments. For Bow-Out loosen (A-3), tighten (A-2) until correct, Then tighten (A-3) back.

5. Set bend Clearance between Nose Bar and Apron for type of material being used. (See Beam Adjustment Chart on pg. 17.)
6. Snug NYLOC Nuts for proper adjustment to prevent Handles from being loose. **HEAD MAY DROP UNEXPECTEDLY IF NOT ADJUSTED PROPERLY.**

>> MACHINE IS NOW READY TO OPERATE <<

RATED BENDING CAPACITY

RATED CAPACITY FOR MILD STEEL

(With **Bending Angle (115)** REMOVED for narrow or offset bends)

Machine Gauge	Capacity
18	20
16	18
14	16
12	14

RATED CAPACITY FOR MILD STEEL

(With **BOTH Bending Angle (115)** and ***Optional* Blade Insert (114)** REMOVED)

FLOOR MODELS ONLY

Machine Gauge	Capacity
18	22
16	20
14	18
12	16

RATED CAPACITY FOR STAINLESS STEEL

Machine Gauge	Capacity
18	22
16	20
14	18
12	16

**** ALL BRAKES ARE RATED TO BEND A 1" FLANGE ****

PREVENTATIVE MAINTENANCE

1. Lubricate machine as recommended. Lubrication points are shown on Parts list List. Recommended WEEKLY lubrication to ALL lubrication points. Lasting Accuracy DEPENDS on proper lubrication.

RECOMMENDED LUBRICANTS

Lubricate ALL moving parts of the machine with Light Grease or Heavy Oil, such as **Mobil Mobility AW-1** or **Equivalent**.

TROUBLE - SHOOTING

1. Brake "Overbending" Material
 - A.) See Set - Up Procedures
2. Brake "Underbending" Material
 - A.) See Set - Up Procedures

WARRANTY

National Sheet Metal Machines, Inc. warrants this product to be free of defects in material and / or workmanship for a period of **THREE (3) YEARS** from the date of purchase. National Sheet Metal Machines, Inc. promises to replace any of this product that proves upon our inspection and within **THREE (3) YEARS** from date of purchase to be defective in material or workmanship.

All labor and / or transportation cost or charges incidental to warranty service are at the expense and shall be borne by the Purchaser / User.

In **NO** event shall National Sheet Metal Machines, Inc. be liable for incidental or consequential damages, for damages as a result of neglect, misuse, abuse, or alterations of any kind to the machine.

No person is authorized to change, add to, or create any warranty of obligation other than that set forth herein.

It is the Purchaser / User's sole responsibility to obtain material that is **AT** or **BELOW** specified standards.

National Sheet Metal Machines, Inc. accepts **NO** liability or assumes any responsibility for damages, accident or injury, or any charges incurred as a result of this machine.

To obtain Warranty service, contact the dealer from which machine was purchased.

National Sheet Metal Machines, Inc.
252 Smartt Station Road
Smartt, Tennessee 37378
(931) 668-3643
WWW.NATIONAL-1.COM

MADE IN THE U.S.A.